

TECHNICAL MANUAL
DIRECT SUPPORT MAINTENANCE REPAIR
PARTS AND SPECIAL TOOLS LIST
FOR
COMMUNICATIONS CENTRAL
AN/ASC-15A(V) 1
(NSN 5895-01-040-9660)
AND
AN/ASC-15A(V)2
(N SN 5895-01-040-9661)

HEADQUARTERS, DEPARTMENT OF THE ARMY

1 SEPTEMBER 1983

**DIRECT SUPPORT MAINTENANCE
REPAIR PARTS AND SPECIAL TOOLS LIST**

FOR

**COMMUNICATIONS CENTRAL
AN/ASC-15A(V)1 (NSN 5896-01-040-9660)
AND
AN/ASC-15A(V)2 (NSN 5895-01-040-9661)**

Current as of 8 March 1983

REPORTING ERRORS AND RECOMMENDING IMPROVEMENTS

You can help improve this manual. If you find any mistakes or if you know of a way to improve the procedures, please let us know. Mail your letter, DA Form 2028 (Recommended Changes to Publications and Blank Forms), or DA Form 2028-2 located in the back of this manual directly to Commander, US Army Communications-Electronics Command and Fort Monmouth, ATTN: DRSEL-ME-MP, Fort Monmouth, NJ 07703.

In either case, a reply will be furnished directly to you.

SECTION			Page	Illus Figure
	I.	Introduction.....	1	
	II.	Repair Parts List.....	15	
GROUP	00	Communications Central AN/ASC-15A(V)1 and AN/ASC-15A(V)2	15	1
	01	Base Plate Assembly (Lower)	17	2
		0101 Mounting Assembly MT-3664/ARC-131 (See TM 11-5820-670-34P for parts)		
		0102 Mounting Plate Assembly (Lower).....	17	2
	02	Base Plate Assembly (Upper) (V1) Only.....	21	3
	03	Box Assembly (Interphone Junction)	23	4
	04	Cable Assembly RF (ARC-164 Coax).....	25	5
	05	Cable Assembly (Power and Control).....	29	6
	06	Cable Assembly (Junction Box)	33	7
	07	Control Cable Assembly (FM-1, FM-2, ARC-131 and KY-287).....	45	8
	08	Control Cable Assembly (FM-3. ARC-131 and KY-28).....	55	9
	09	Secure Retransmission Wire Harness Assembly	63	10
	10	Cable Assembly Control.....	65	11
	11	Cable Assembly (Station 1-6).....	69	12
	12	Cable Harness Assembly (Station 1-6).....	77	13

***This manual supersedes TM 11-5821-285-30P, 12 January 1983.**

		Page	Illus Figure
GROUP	13 Security Device TSEC'KY-28 (See TM 11-5110-244-34P for parts)		
	14 Connector and Cover Assembly KY-28.....	79	14
	1401 Bracket Assembly	79	14
	1402 Cable Assembly	81	15
	15 Control Indicator C-8157,ARC (See TM 11-5895-555-23P for parts)		
	16 Control Intercommunications Set C-1611()IAIC (See TM 11-5831-201-34P for parts)		
	17 Frame Assembly V1 and V2	89	16
	1701Adapter. Power Supply U-383()'VR (See TM 11-5805-552-15P for parts)		
	18 AN,ASC-15A(V)1 and IV)2 Installation Kit UH-IDH.....	95	17
	1801 Cable Assembly (Coax).....	97	18
	1802 Cable Assembly (Coax) (See Group 1801 for parts)		
	1803 Cable Assembly (Coax) FM-1, FM-2, FM-3.....	99	19
	1804 Control Coupler Cable FM-1, FM-2, FM-3	103	20
	1805 Power Cable Assembly	105	21
	1806 'Y" Cable Assembly (Console to UH-D Intercom)	107	22
	19 Repeater Mount Assembly	109	23
	20 Radio Set AN ARC-131 IFM-1, FM-2, FM-3) (See TM 11-5820-670-34P for parts)		
	21 Radio Receiver-Transmitter RT-1167'ARC-164(V) (See TM 11-5821-311-34P for parts)		
	22 Repeater Shock Mount Assembly	109	23
	2201 Cable Assembly (Repeater Shockmount).....	111	24
	23 Regenerative Receiver TSECiHYL-3 (See TM 11-5810-247-12P for parts)		
	24 Radio Junction Box Assembly.....	113	25
	2401 Audio Pad Assembly	115	26
	25 AN,ARC-51 Coax Cable.....	117	27
	26 Radio Set AN ARC-51BX (V2 Only) (See TM 11-5820-518-34P for parts)		
	99 Bulk Materials.....	118	
Section	III. Special Tools list (Not applicable)		
	IV. National Stock Number and Part Number Index.....	122	

**SECTION I
INTRODUCTION**

1. Scope

This manual lists spares and repair parts; special tools; special test, measurement, and diagnostic equipment (TMDE), and other special support equipment required for performance of direct support maintenance of the AN/ASC-15A(V)1 and (V)2. It authorizes the requisitioning and issue of spares and repair parts as indicated by the source and maintenance codes.

2. General

This Repair Parts and Special Tools List is divided into the following sections:

a. Section II. Repair Parts List. A list of spares and repair parts authorized for use in the performance of maintenance. The list also includes parts which must be removed for replacement of the authorized parts. Parts lists are composed of functional groups in numeric sequence, with the parts in each group listed in figure and item number sequence.

b. Section III. Special Tools List. Not applicable.

c. Section IV. National Stock Number and Part Number Index. A list, in National item identification number (NIIN) sequence, of all National stock numbers (NSN) appearing in the listings, followed by a list, in alphameric sequence, of all part numbers appearing in the listings. National stock numbers and part numbers are cross-referenced to each illustration figure and item number appearance.

3. Explanation of Columns

a. Illustration. This column is divided as follows:

(1) *Figure number.* Indicates the figure number of the illustration on which the item is shown.

(2) *Item number.* The number used to identify item called out in the illustration.

b. Source, Maintenance, and Recoverability (SMR) Codes.

(1) *Source code.* Source codes indicate the manner of acquiring support items for maintenance, repair, or overhaul of end items. Source codes are entered in the first and second positions of the Uniform SMR Code format as follows:

Code Definition

PA- Item procured and stocked for anticipated or known usage.

PD- Support item, excluding support equipment, procured for initial issue or outfitting and

Code Definition

stocked only for subsequent or additional initial issues or outfittings. Not subject to automatic replenishment.

MD- Item to be manufactured or fabricated at the depot maintenance level.

AF- Item to be assembled at direct support maintenance level.

XB- Item is not procured or stocked. If not available through salvage, requisition.

NOTE

Cannibalization or salvage may be used as a source of supply for any items source coded above except those coded XA and aircraft support item as restricted by AR 700-42.

(2) *Maintenance code.* Maintenance codes are assigned to indicate the levels of maintenance authorized to USE and REPAIR support items. The maintenance codes are entered in the third and fourth positions of the Uniform SMR Code format as follows:

(a) The maintenance code entered in the third position will indicate the lowest maintenance level authorized to remove, replace, and use the support item. The maintenance code entered in the third position will indicate one of the following levels of maintenance:

Code Application/Explanation

O-- Support item is removed, replaced, used at the organizational level.

F-- Support item is removed, replaced, used at this direct support level.

(b) The maintenance code entered in the fourth positions indicates whether the item is to be repaired and identifies the lowest maintenance level with the capability to perform complete repair (i.e., all authorized maintenance functions). This position will contain one of the following maintenance codes:

Code Application/Explanation

F- The lowest maintenance level capable of complete repair of the support item is the direct support level.

D- The lowest maintenance level capable of complete repair of the support item is the depot level.

Code Application Explanation

L- Repair restricted to designated specialized repair activity.

Z- Nonreparable. No repair is authorized.

(3) *Recoverability code.* Recoverability codes are assigned to support items to indicate the disposition action on unserviceable items. The recoverability code is entered in the fifth position of the Uniform SMR Code format as follows:

Recoverability codes Definition

Z- Nonreparable item. When unserviceable, condemn and dispose at the level indicated in position 3.

F-- Repairable item. When uneconomically repairable, condemn and dispose at the direct support level.

D- Repairable item. When beyond lower level repair capability, return to depot. Condemnation and disposal not authorized below depot level.

L- Repairable item. Repair, condemnation, and disposal not authorized below depot/specialized repair activity level.

c. *National Stock Number.* Indicates the National stock number assigned to the item and will be used for requisitioning purposes.

d. *Federal Supply Code for Manufacturer (FSCM).* The FSCM is a 5-digit numeric code listed in SB 708-41/42 which is used to identify the manufacturer, distributor, or Government agency, etc.

e. *Part Number.* Indicates the primary number used by the manufacturer (individual, company, firm, corporation, or Government activity), which controls the design and characteristics of the item by means of its engineering drawings, specifications, standards, and inspection requirements to identify an item or range of items.

NOTE

When a stock numbered item is requisitioned, the repair part received may have a different part number than the part being replaced.

f. *Description.* Indicates the Federal item name and, if required, a minimum description to identify the item.

g. *Unit of Measure (U/M).* Indicates the standard of the basic quantity of the listed item as used in performing the actual maintenance function. This measure is expressed by a two-character alphabetical abbreviation (e.g., ea, in, pr, etc). When the unit of measure differs from the unit of issue, the lowest unit of issue that will satisfy the required units of measure will be requisitioned.

h. *Quantity Incorporated in Unit.* Indicates the quantity of the item used in the breakout shown on the illustration figure, which is prepared for a functional group, subfunctional group, or an assembly. A "V" appearing in this column in lieu of a quantity indicates that no specific quantity is applicable, (e.g., shims, spacers, etc).

4. Special Information

a. Usable on codes are shown in the description column. Uncoded items are applicable to all models. Identification of the usable on codes used in this publication are:

<i>Code</i>	<i>Used on</i>
EZ3	AN/ASC-15A(V)1
EZ4	AN/ASC-15A(V)2

b. Detailed manufacturing instructions for items source coded to be manufactured or fabricated are found in TM 11-5821-285-34. Bulk materials required to manufacture items are listed in the Bulk Material Group of this manual.

c. Detailed assembly instructions for items source coded to be assembled are found in TM 11-5821-298-34. Assembly components are listed immediately following the item to be assembled.

d. The following publications pertain to the AN/ASC-15A(V)1 and AN/ASC-15A(V)2 and their components:

- TM 11-1520-207-20P, Installation Items for Electronic Equipment in UH-1A, UH-1B and UH-1D Helicopters.
- TM 11-1520-207-35P, Installation Items for Electronic Equipment in UH-1A, UH-1B and UH-1D Helicopters.
- TM 11-1520-210-20, Electronic Equipment Configurations, Army Models UH-LD, UH-1H and EH-1H Helicopters.
- TM 11-1520-210-20-1, Electronic Equipment Configurations, Army Model UH-1H Helicopter (W/Standard Lightweight Avionics Equipment).
- TM 11-1520-210-20P, Electronic Equipment Configuration, Army Model UH-1D and UH-1H Helicopters.
- TM 11-1520-210-20P-1, Electronic Equipment Configuration, Army Model UH-1H (With SLAE).
- TM 11-1520-210-34-1, Electronic Equipment Configuration, Army Model UH-1H Helicopter (With Standard Lightweight Avionics Equipment).
- TM 11-1520-210-35, Electronic Equipment Configuration, Army Models UH-1D Helicopter UH-1H and EH-1H.
- TM 11-1520-211-20, Electronic Equipment Configurations, Army Models UH-1B and UH-1C/M Helicopters.

TM 11-1520-211-35, Electronic Equipment Configurations, Army Models UH-1B and UH-1C/M.
 TM 11-5805-552-15P, Adapter, Power Supply U-383()/VR.
 TM 11-5810-244-10, Communication Security Equipment, TSEC/KY-28.
 TM 11-5810-244-20, Speech Security Equipment Airborne, TSEC/KY-28.
 TM 11-5810-244-34P, Communication Security Equipment, TSEC/KY-28.
 TM 11-5810-247-10, Communication Security Equipment, TSEC/HYL-3.
 TM 11-5810-247-12P, Communication Security Equipment, TSEC/HYL-3.
 TM 11-5810-247-34, Communication Security Equipment, TSEC/HYL-3.
 TM 11-5810-247-34P, Communication Security Equipment, TSEC/HYL-3.
 TM 11-5820-518-20, Radio Sets AN/ARC-51X and AN/ARC-51BX.
 TM 11-5810-518-20P, Radio Sets AN/ARC-51X and AN/ARC-51BX.
 TM 11-5810-518-34P, Radio Sets AN/ARC-51X and AN/ARC-51BX.
 TM 11-5820-670-12, Radio Sets AN/ARC-131.
 TM 11-5820-670-20P, Radio Sets AN/ARC-131.
 TM 11-5820-670-34, Radio Set, AN/ARC-131.
 TM 11-5820-670-34P, Radio Set, AN/ARC-131.
 TM 11-5821-244-12, Radio Set, AN/ARC-54.
 TM 11-5821-244-20P, Radio Set, AN/ARC-54.
 TM 11-5821-244-34, Radio Set, AN/ARC-54.
 TM 11-5821-244-34P, Radio Set, AN/ARC-54.
 TM 11-5821-285-12, Communications Central, AN/ASC-15.
 TM 11-5821-285-20P, Communications Central, AN/ARC-15A(V)1 and AN/ARC-15A(V)2.
 TM 11-5821-285-35, Communications Center, AN/ASC-15.
 TM 11-5821-311-12, Receiver-Transmitter, Radio RT-1167/ARC-164(V).
 TM 11-5821-311-20P, Receiver-Transmitter, Radio RT- 1167/ARC- 164(V).
 TM 11-5821-311-34, Receiver-Transmitter, Radio RT- 1167/ARC- 164(V).
 TM 11-5821-311-34P, Receiver-Transmitter, Radio RT-1167/ARC-164(V).
 TM 11-5831-201-20, Control, Intercommunication Set C-1611D/AIC and Discriminator, Discrete Signal MD-736/A.
 TM 11-5831-201-20P, Control, Intercommunica-

tion Set C-1611D/AIC and Discriminator, Discrete Signal MD-736/A.
 TM 11-5831-201-34P, Control, Intercommunication Set C-1611D/AIC and Discriminator, Discrete Signal MD-736/A.
 TM 11-5831-201-35, Control, Intercommunication Set C-1611D/AIC and Discriminator, Discrete Signal MD-736/A.
 TM 11-5895-555-23P, Control, Indicator, C-8157/ARC and Mounting, MT-3802/ARC.
 TM 11-5895-555-24, Control Indicator, C-8157/ARC and Mounting MT-3802/ARC.

e. National stock numbers (NSN's) that are missing from P source coded items have been applied for and will be added to this TM by future change/revision when they are entered in the Army Master Data File (AMDF). Until the NSN's are established and published, submit exception requisitions to:

Commander, US Army Communications-Electronics Command and Fort Monmouth, ATTN: DR-SEL-MM, Fort Monmouth, New Jersey 07703 for the part required to support your equipment.

5. How to Locate Repair Parts

a. When National stock number or part number is unknown.

(1) *First.* Using the table of contents, determine the functional group within which the item belongs. This is necessary since illustrations are prepared for functional groups and listings are divided into the same groups.

(2) *Second.* Find the illustration covering the functional group to which the item belongs.

(3) *Third.* Identify the item on the illustration and note the illustration figure and item number of the item.

(4) *Fourth.* Using the Repair Parts Listing, find the figure and item number noted on the illustration.

b. When National stock number or part number is known,

(1) *First.* Using the index of National Stock Numbers and Part Numbers, find the pertinent National stock number or part number. This index is in NIIN sequence followed by a list of part numbers in alphameric sequence, cross-referenced to the illustration figure number and item number.

(2) *Second.* After finding the figure and item number, locate the figure and item number in the repair parts list.

6. Abbreviations

Not applicable.

(Next printed page is 6)

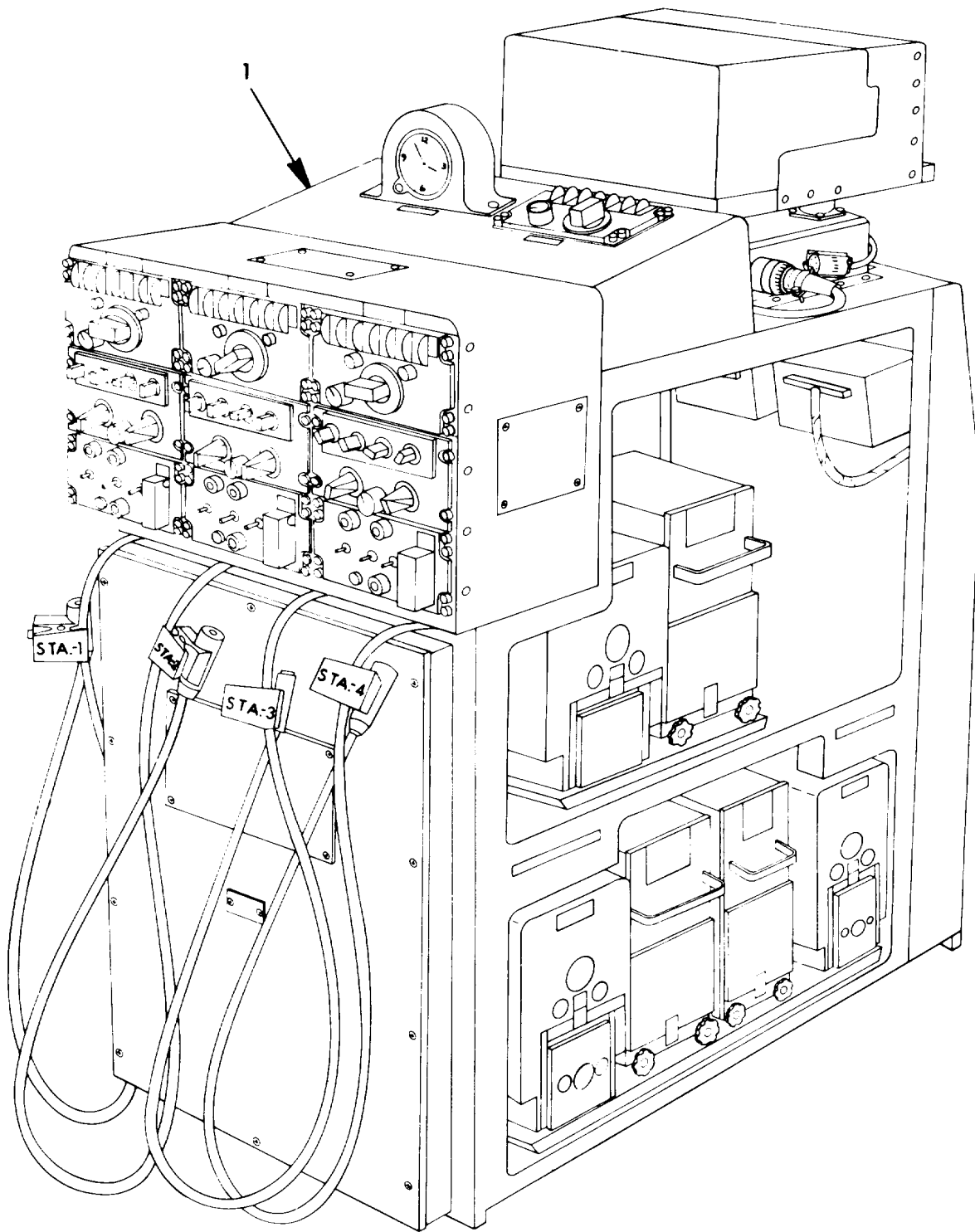

NOTE: TYPICAL (V)1 VERSION

EL85A001

Figure 1. Communications Central AN/ASC-15A(V)1 and 2 (Sheet 1 of 9).

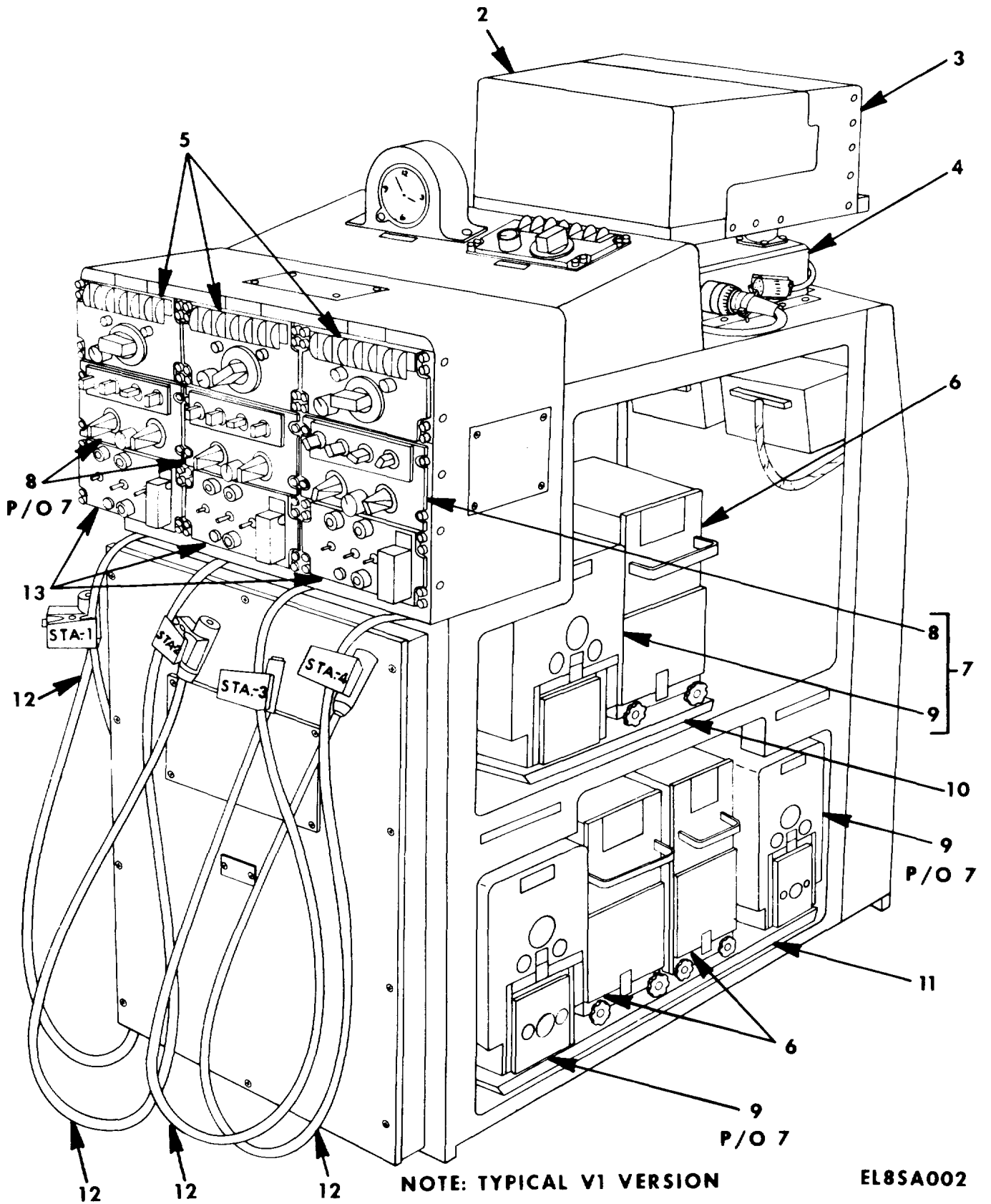
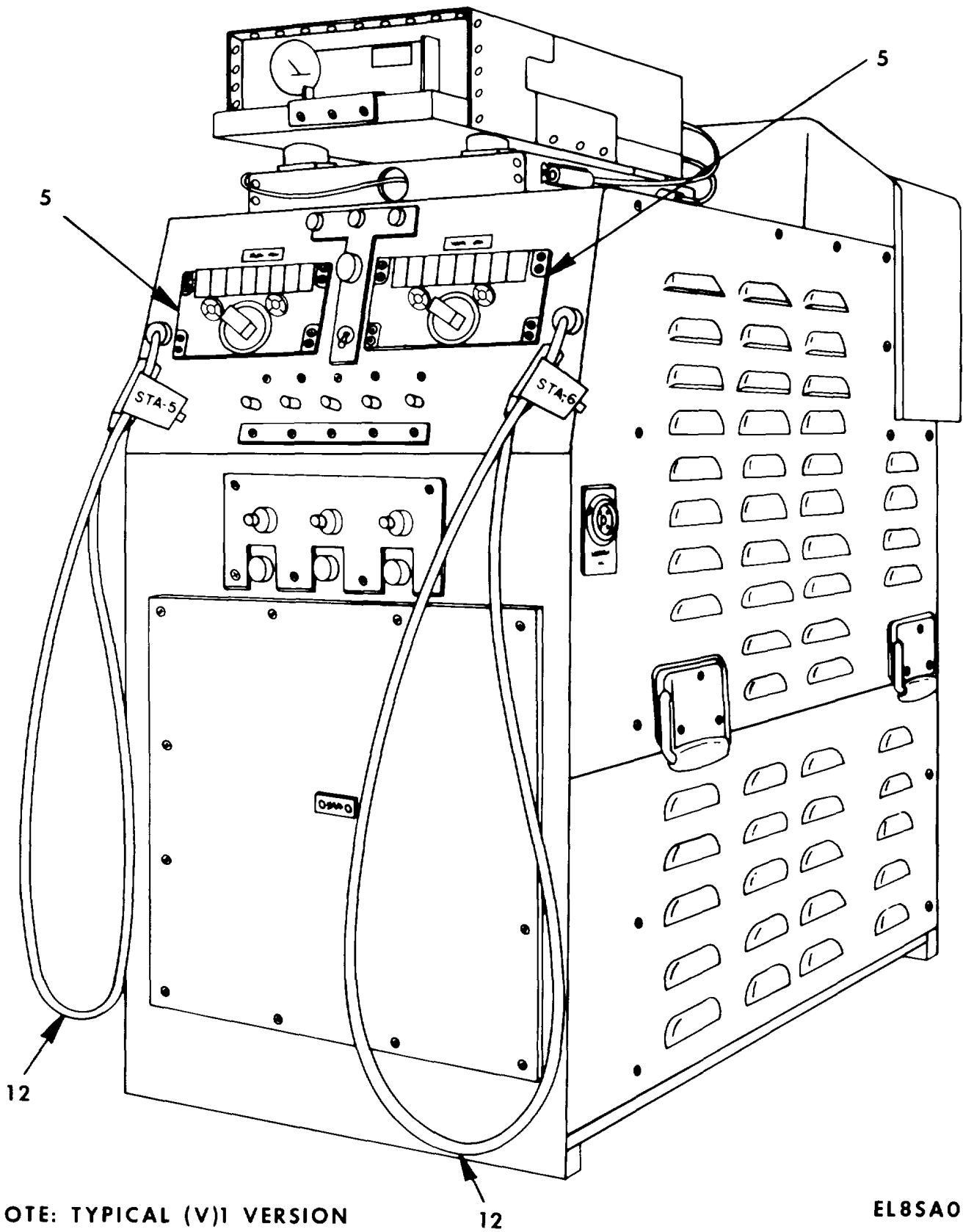

Figure 1. Communications Central AN/ASC-15(V)1 and 2 (Sheet 2 of 9).



NOTE: TYPICAL (V)1 VERSION

EL85A003

Figure 1. Communications Central AN/ASC-15(V)1 and 2 (Sheet 3 of 9).

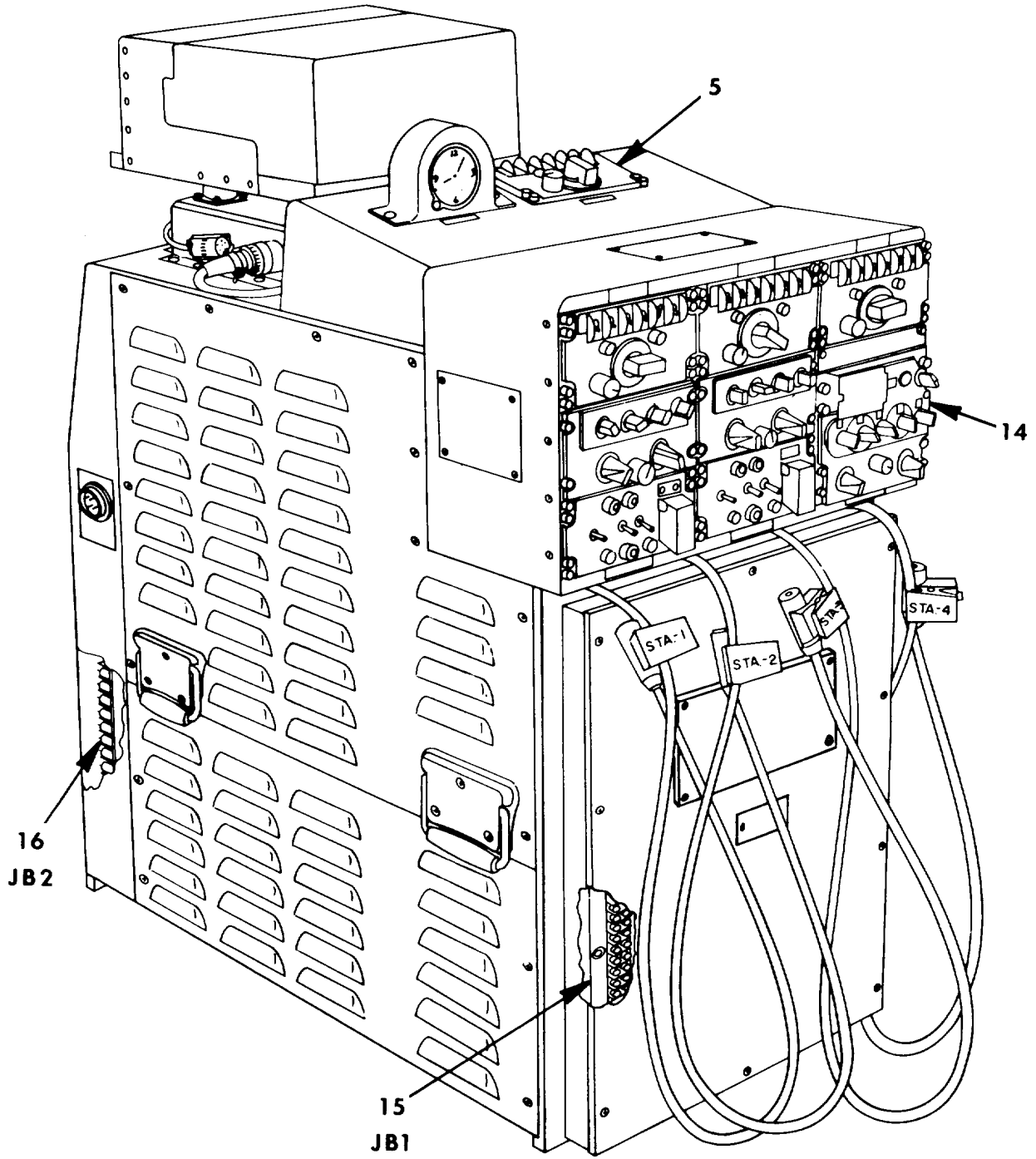

NOTE: TYPICAL (V)1 VERSION

EL8SA004

Figure 1. Communications Central AN/ASC-15(V)1 and 2 (Sheet 4 of 9).

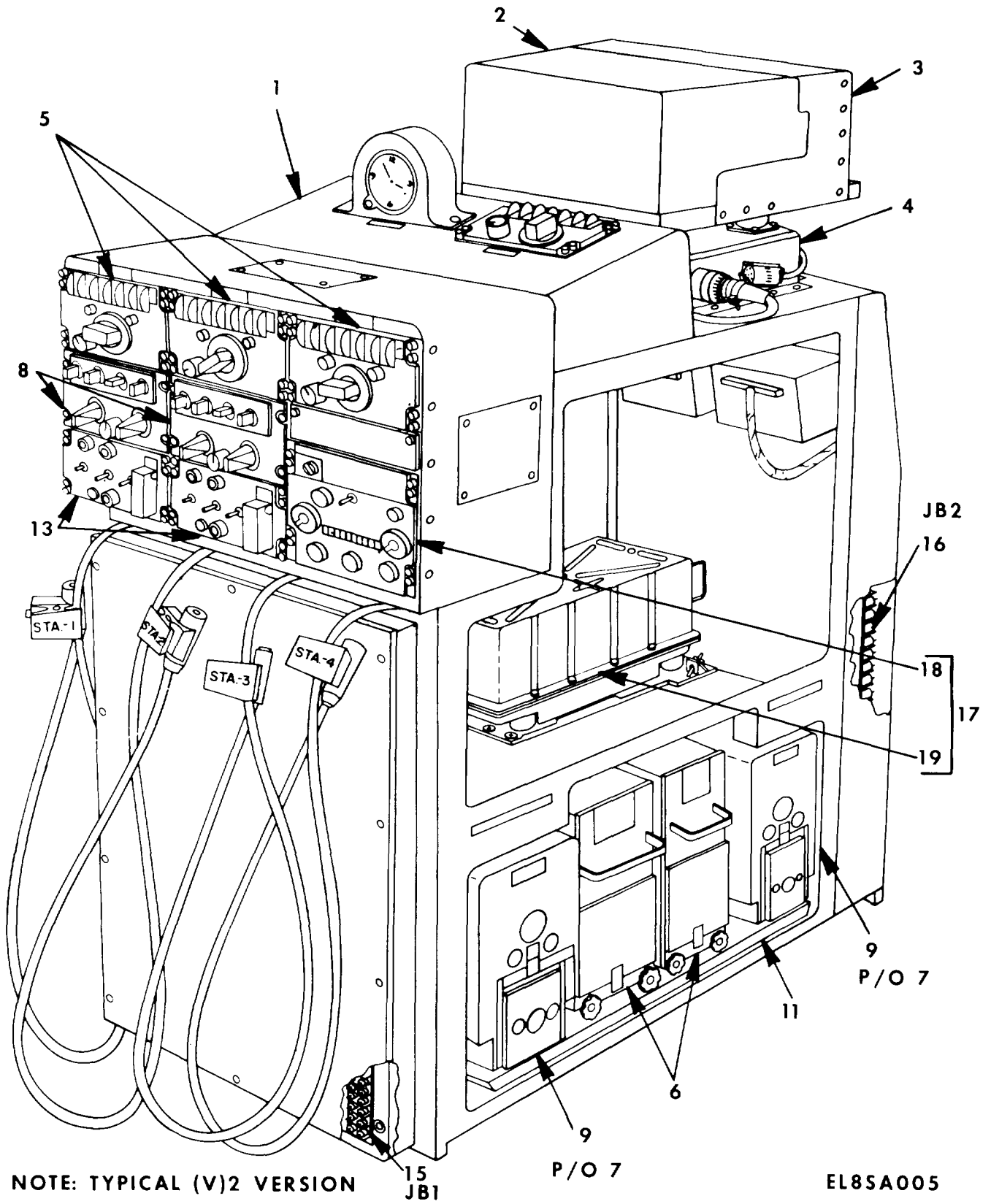
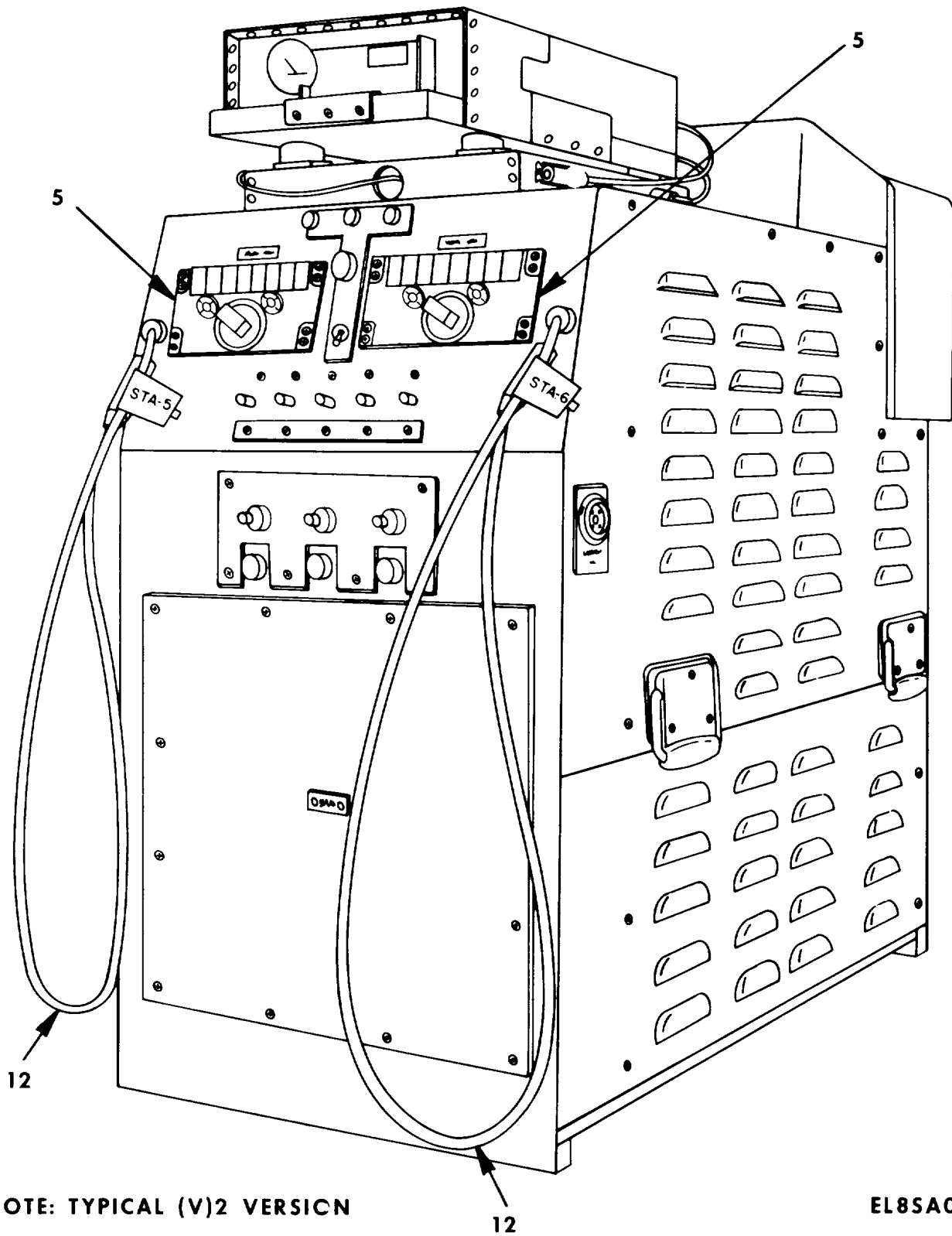

Figure 1. Communications Central AN/ASC-15(V)1 and 2 (Sheet 5 of 9).



NOTE: TYPICAL (V)2 VERSION

EL85A006

Figure 1. Communications Central AN/ASC-15(V)1 and 2 (Sheet 6 of 9).

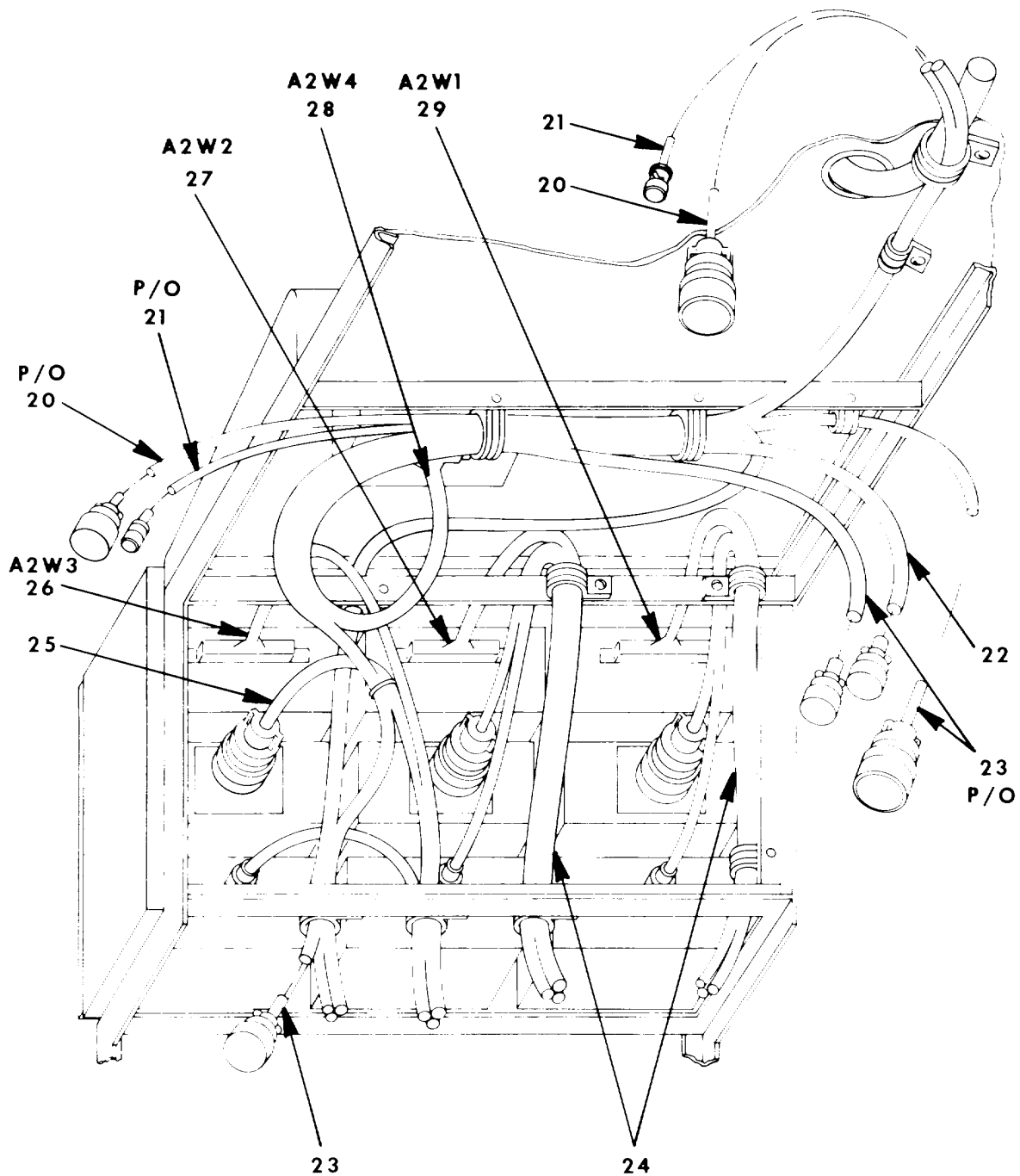

EL85A007

Figure 1. Communications Central AN/ASC-15(V)1 and 2 (Sheet 7 of 9).

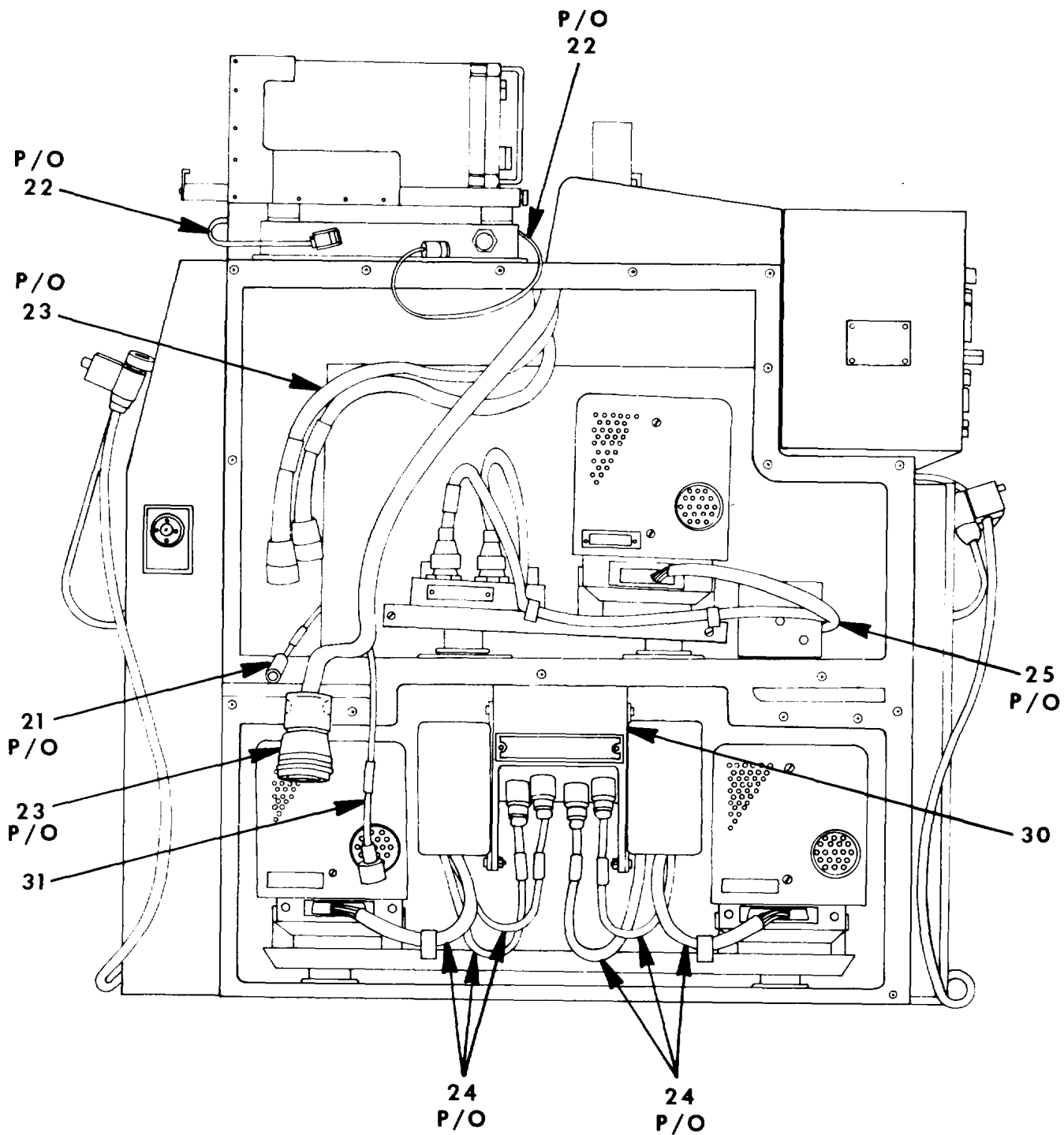

EL85A008

Figure 1. Communications Central AN/ASC-15(V)1 and 2 (Sheet 8 of 9).

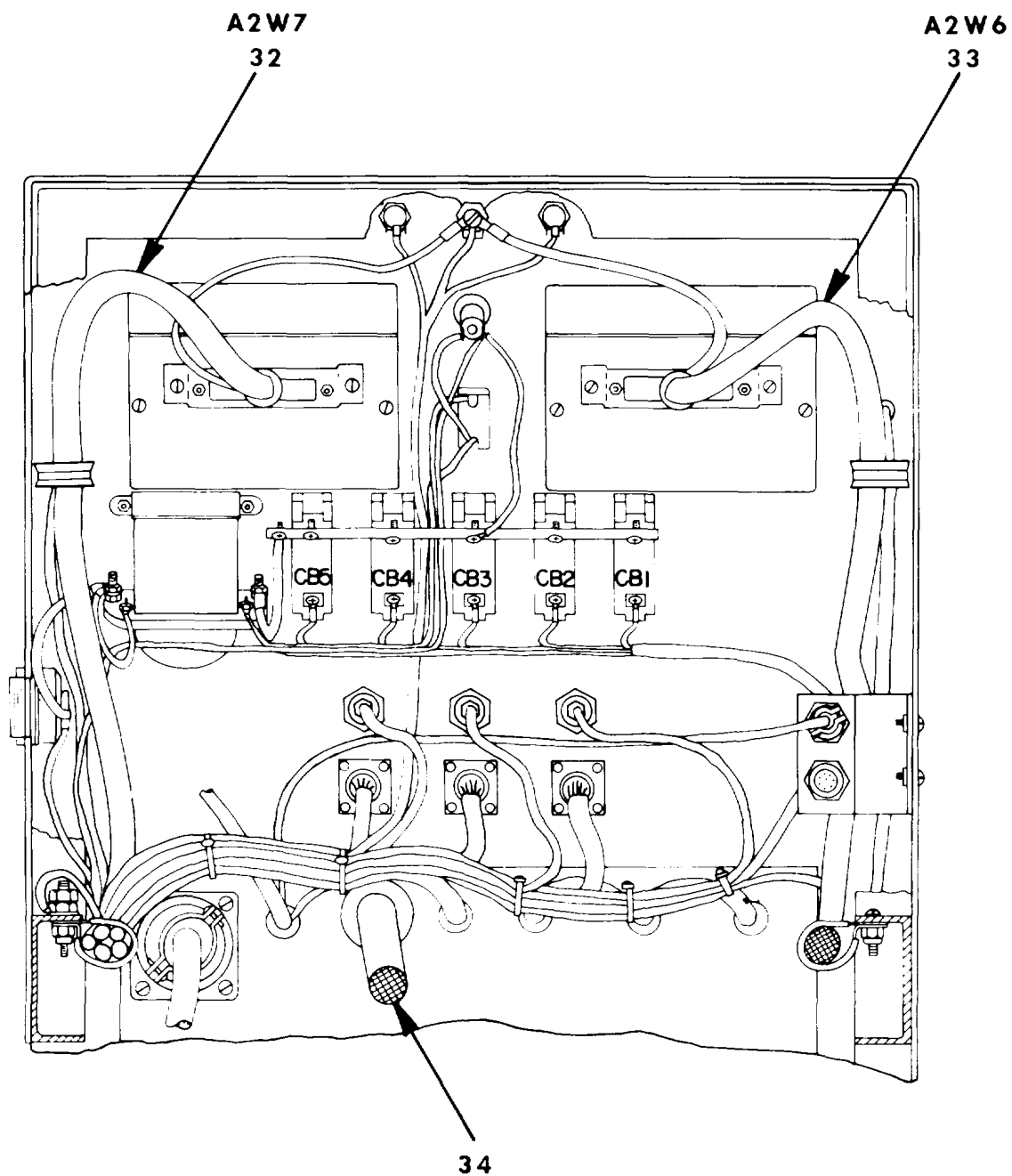

EL8SA009

Figure 1. Communications Central AN/ASC-15(V)1 and 2 (Sheet 9 of 9)

SECTION II

TM 11 5821-285-30P

(1) ILLUSTRATION		(2)	(3)	(4)	(5)	(6)	(7)	(8)
(a) FIG NO.	(b) ITEM NO.	SMR CODE	NATIONAL STOCK NUMBER	FSCM	PART NUMBER	DESCRIPTION USABLE ON CODE	U/M	QTY INC IN UNIT
						GROUP 00 COMMUNICATIONS CENTRAL AN/ASC-15A(V)1 AND AN/ASC-15A(V)2		
1	1	XBFFF		80063	SC-D-972561	FRAME ASSEMBLY SEE FIGURE 16 FOR PARTS	EA	1
1	2	PDODD	5810-00-877-8391	80058	HYL3TSEC	TACTICAL DIGITAL RE.....	EA	1
1	3	XBOFF		80063	SC-D-972653	MOUNT ASSY REPEATERSEE FIGURE 23 FOR PARTS		EA 1
1	4	XBFFF		80063	SC-D-972648	SHK MT ASSY RPTR SEE FIGURE 23 FOR PARTS	EA	1
1	5	PDODD	5831-00-933-9822	80058	C1611DA1C	CONTROL,INTERCOMMUN	EA	6
1	6	PAOLL	5810-00-919-4554	80058	TSEC/KY-28	TSECKY28 PHY-SEC-CL (C).....EZ3	EA	3
1	7	PDODD	5821-00-937-4686	80058	ANARC131	RADIO SET 3EA USED ON V1 2EA USED ON V2 ...EZ4	EA	2
1	8	PAODD	5821-00-937-9614	80058	C7088/ARC-131	CONTROL.RADIO SET 3EA USED ON V1 2EA USED ON V2.....EZ4	EA	2
1	9	PAODD	5821-00-851-1096	80058	RT-E23/ARC-131	RECIEVER TRANSMITTE 3EA USED ON V1 2EA USED ON V2.....EZ3	EA	3
1	10	XBOFF		80063	SC-D-972582	BASE PLATE ASSY UPR SEE FIGURE 3 FOR PARTS	EZ3	EA 1
1	11	XBOFF		80063	SC-D-972593	BASE PLATE ASSY SEE FIGURE 2 FOR PARTS.....	EA	1
1	12	AFFFF		80063	SC-C-972801-4	CABLE ASSY STA 4	EA	1
1	13	PAODD	5821-00-926-7230	80058	C8157ARC	SEE FIGURE 12 FOR PARTS CONTROL,INDICATOR 3 EA USED ON V1, 2 EA USED ON V2	EZ3	EA 3
1	14	PDODD	5821-00-138-7990	80058	RT-1167/ARC-164	RECEIVER-TRANSMITTE.....	EA	1
1	15	XBOFF		80063	SC-D-972610	BOX ASSY INTPH JCT SEE FIGURE 4 FOR PARTS	EA	1
1	16	XBFFF		80063	SC-D-972599	TERMINAL BOX ASSY SEE FIGURE 25 FOR PARTS	EA	1
1	17	PDODD	5821-00-082-3926	80058	ANARC51BX	RADIO SET	EZ4	EA 1
1	18	XBODD	5821-00-082-3928	80058	C6287/ARC-518X	CONTROL,RADIO SET	EZ4	EA 1
1	19	PAODD	5821-00-082-3927	80058	RT742/ARC-51BX	RECEIVER-TRANSHITTE	EZ4	EA 1
1	20	AFFFF		80063	SC-D-972713	CABLE ASSEMBLY SEE FIGURE 11 FOR PARTS	EA	1
1	21	AFOFF		80063	SC-C-972717	CABLE ASSEMBLY SEE FIGURE 5 FOR PARTS	EA	1
1	22	AFFFF		80063	SC-D-972711	CABLE ASSEMBLY SEE FIGURE 10 FOR PARTS	EA	1
1	23	AFFFF		80063	SC-D-972706	CABLE ASSEMBLY SEE FIGURE 6 FOR PARTS	EA	1
1	24	AFFFF		80063	SC-D-972708	CABLE ASSEMBLY SEE FIGURE 8 FOR PARTS	EA	1
1	25	AFFFF		80063	SC-D-972709	CABLE ASSEMBLY SEE FIGURE 9 FOR PARTS	EA	1
1	26	AFFFF		80063	SC-D-972702	CABLE HARNESS ASSY SEE FIGURE 13 STATION 3 FOR PARTS.....	EA	1
1	27	PAFFFF		80063	SC-D-972701	CABLE HARNESS ASSY SEE FIGURE 13 STATION 2 FOR PARTS.....	EA	1
1	28	AFFFF		80063	SC-D-972703	CABLE HARNESS ASSY SEE FIGURE 13 STATION 4 FOR PARTS.....	EA	1
1	29	AFFFF		80063	SC-D-972700	CABLE HARNESS ASSY SEE FIGURE 13 STATION 1 FOR PARTS.....	EA	1
1	30	XBOFF		80063	SC-D-972614	CONN & COV ASSY SEE FIGURE 14 FOR PARTS	EA	1
1	31	AFFFF		80063	SC-C-972802	CABLE COAX AN/ARCSI SEE FIGURE 27 FOR PARTS	EZ4	EA 1
1	32	AFFFF		80063	SC-D-972705	CABLE HARNESS ASSY SEE FIGURE 13 STATION 1 FOR PARTS.....	EA	1
1	33	AFFFF		80063	SC-D-972704	CABLE HARNESS ASSY SEE FIGURE 13 STATION 6 FOR PARTS.....	EA	1
1	34	AFFFF		80063	SC-D-972707	CABLE ASSEMBLY SEE FIGURE 7 FOR PARTS	EA	1

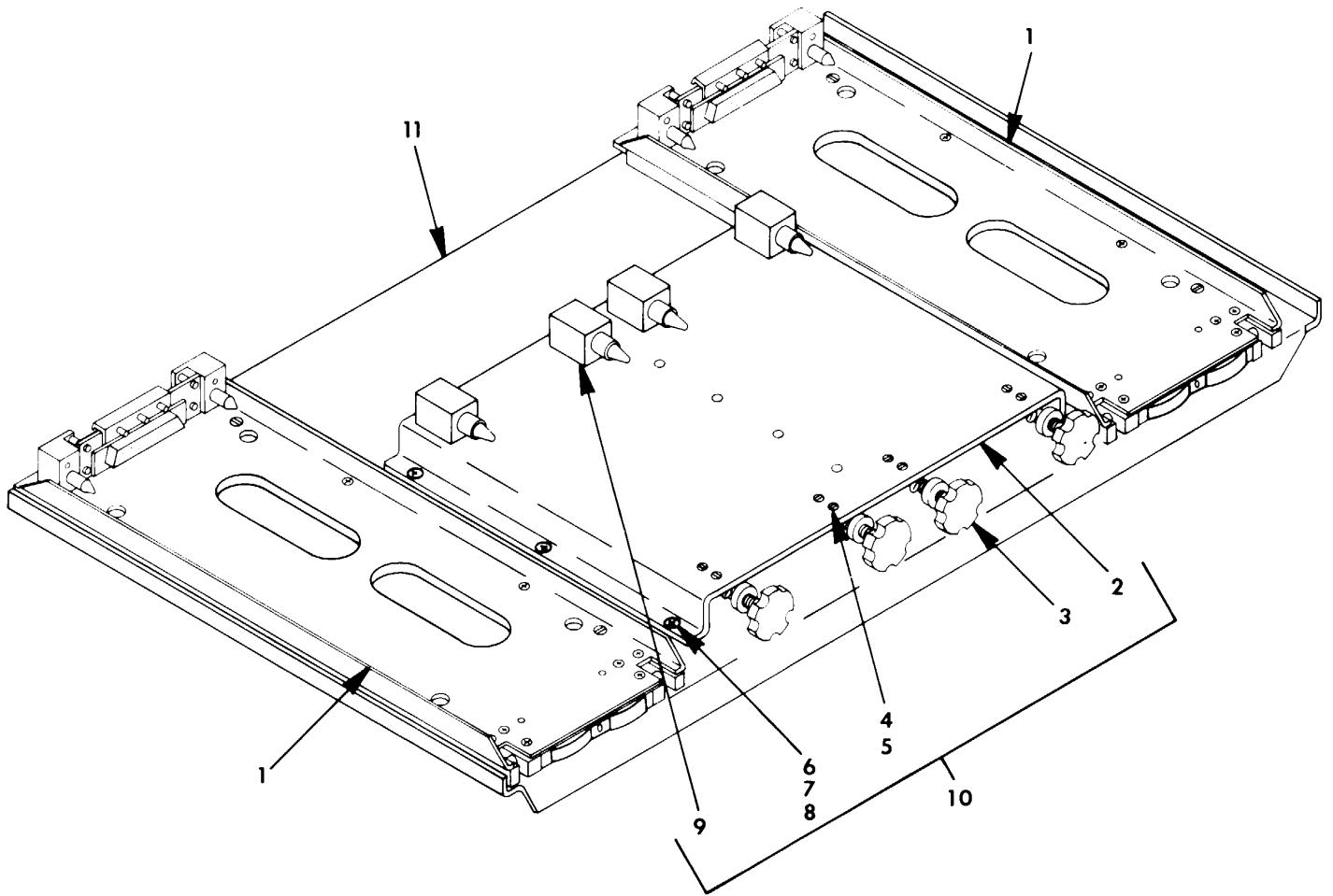

EL85A010

Figure 2. Base Plate Assembly (Lower) and Mounting Plate Assembly (Lower).

SECTION II

TM 11-5821-285-30P

(1) ILLUSTRATION		(2)	(3)	(4)	(5)	(6)	(7)	(8)
(a) FIG NO.	(b) ITEM NO.	SMR CODE	NATIONAL STOCK NUMBER	FSCM	PART NUMBER	DESCRIPTION USABLE ON CODE	U/M	QTY INC IN UNIT
						GROUP 01 BASE PLATE ASSEMBLY (LOWER)		
2	1	XBOFF		80063	SC-D-972592	MOUNTING ASSEMBLY	EA	2
2	2	XAFZZ		80063	SC-D-972597	PLATE LOWER ASSY.....	EA	1
2	3	PAFZZ	5340-00-490-2118	81860	SLR2AB	RETAINER,FRONT,SELF	EA	4
2	4	PAFZZ	5305-00-059-4568	96906	MS35190-253	SCREW,MACHINE	EA	8
2	5	PAFZZ	5310-00-060-2039	96906	MS21044D08	NUT,SELF-LOCKING,HE	EA	8
2	6	PAFZZ	5305-00-984-6194	96906	MS35206-246	SCREWH,MACHINE	EA	10
2	7	PAFZZ	5310-00-809-8546	96906	MS27183-8	WASHER,FLAT	EA	6
2	8	PAFZZ	5310-00-045-3299	96906	MS35338-42	WASHER,LOCK	EA	6
						GROUP 0102 MOUNTING PLATE ASSEMBLY (LOWER)		
2	9	XBFZZ		81860	3098 005 000	CATCH,FRICTION.....	EA	4
2	10	XBOFF		80063	SC-D-972596	MOUNTING PLATE	EA	1
2	11	XAFZZ		80063	SC-D-972594	BASE PLATE ASSEMBLY	EA	1
17/(18 blank)								

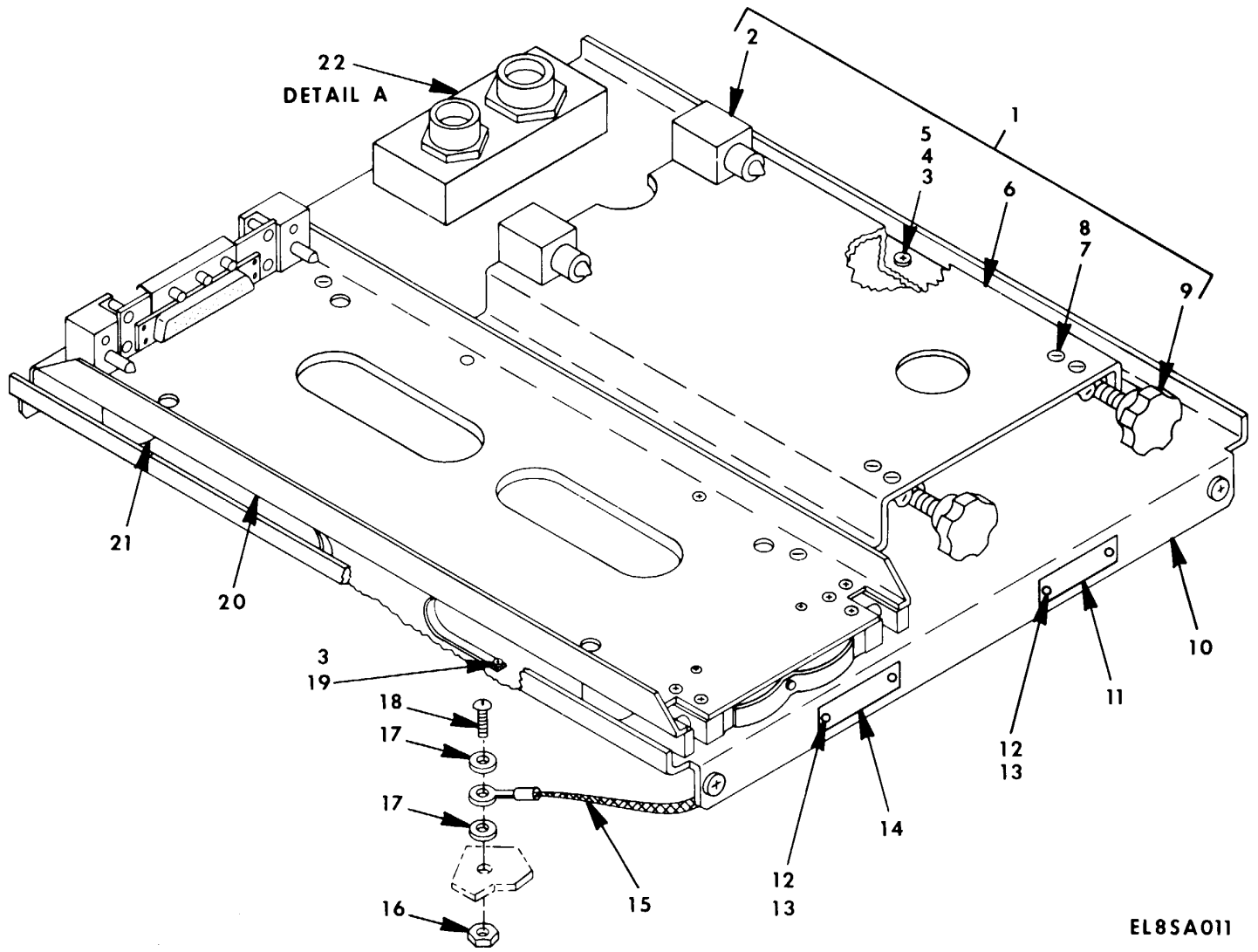
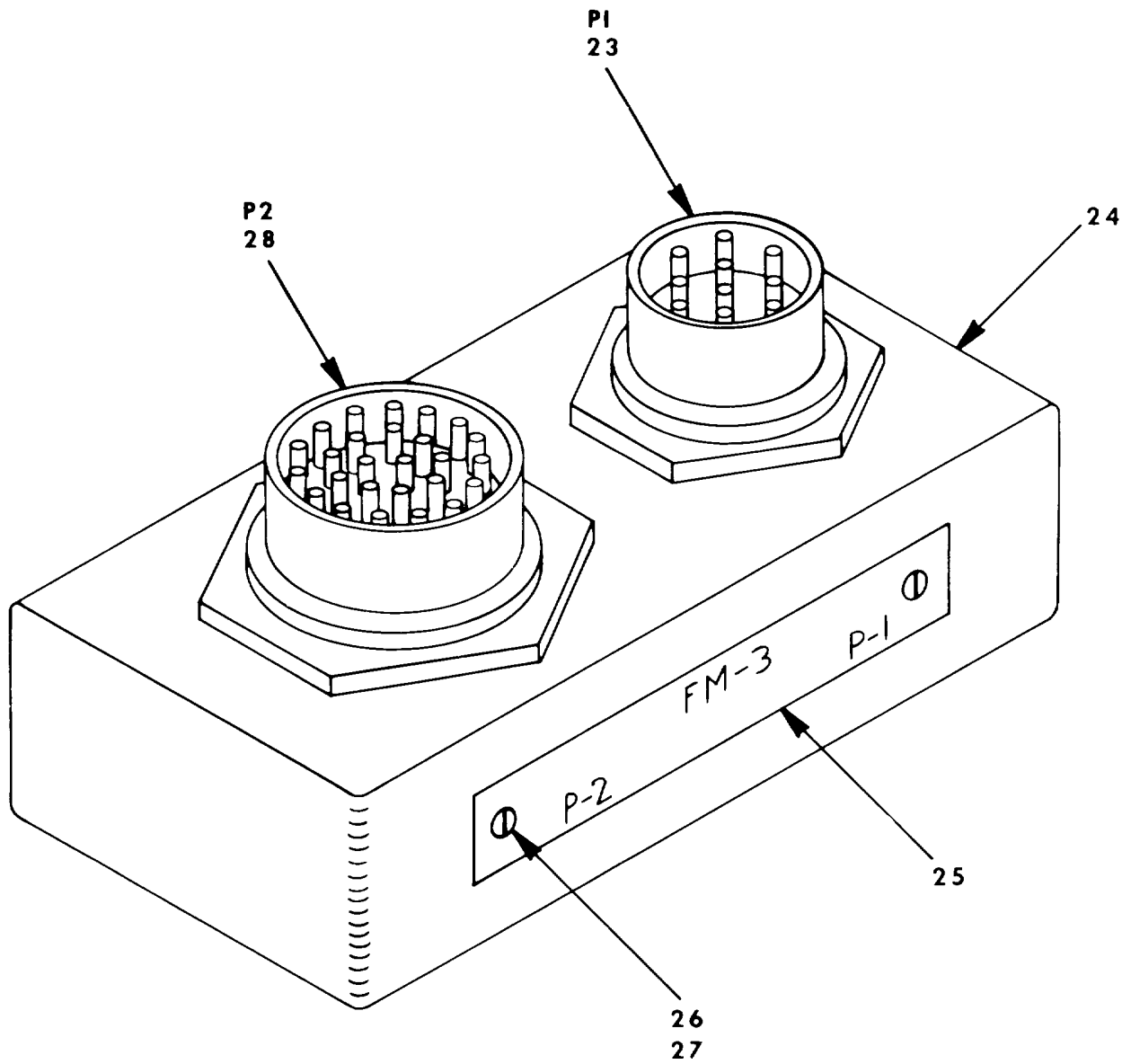

Figure 3. Base Plate Assembly (Upper) (V1 Only) (Sheet 1 of 2).



DETAIL A

EL8SASA012

Figure 3. Base Plate Assembly (Upper) (V1 Only) (Sheet 2 of 2).

SECTION II

TM 11-5821-285-30P

(1) ILLUSTRATION		(2)	(3)	(4)	(5)	(6)	(7)	(8)
(a) FIG NO.	(b) ITEM NO.	SMR CODE	NATIONAL STOCK NUMBER	FSCM	PART NUMBER	DESCRIPTION USABLE ON CODE	U/M	QTY INC IN UNIT
						GROUP 02 BASE PLATE ASSEMBLY (UPPER) (V1 ONLY)		
3	1	XBOFF		80063	SC-D-972585	MOUNTING PLATE ASSY EZ3	EA	1
3	2	XBFZZ		81860	3098 005 000	CATCH, FRICTION.....	EA	2
3	3	PAFZZ	5310-00-559-0070	96906	MS35333-38	WASHER, LOCK EZ3	EA	4
3	4	PAFZZ	5310-00-809-8546	96906	MS27183-8	WASHER, FLAT EZ3	EA	6
3	5	PAFZZ	53L0-00-045-3299	96906	MS35338-42	WASHER, LOCK EZ3	EA	8
3	6	XAFZZ		80063	SC-D-972586	PLATE MOUNTING UPR..... EZ3	EA	1
3	7	PAFZZ	5305-00-059-4568	96906	MS35190-253	SCREW, MACHINE EZ3	EA	4
3	8	PAFZZ	5310-00-982-6814	96906	MS21044C08	NUT, SELF-LOCKING, HE EZ3	EA	4
3	9	PAFZZ	5340-00-490-2118	81860	SLR2AB	RETAINER, FRONT, SELF-	EA	2
3	10	XBOFF		80063	SC-D-972583	BASE PLATE ASSY UPR..... EZ3	EA	1
3	11	XBFZZ		80063	SC-B-972625	PLATE IDENT EZ3	EA	1
3	12	PAFZZ		96906	MS21042-2	NUT SELF-LOCKING EZ3	EA	4
3	13	PAFZZ	5305-00-988-1167	96906	MS35206-204	SCREW, MACHINE EZ3	EA	4
3	14	XBFZZ		80063	SC-B-972624	PLATE IDENT EZ3	EA	1
3	15	XBFZZ		80063	SC-C-972651	GROUND STRAP ASSY EZ3	EA	8
3	16	PAFZZ	5310-00-807-1466	96906	MS21042-08	NUTT SELF-LOCKING, EX EZ3	EA	16
3	17	XAFZZ		88044	AN93688	WASHER, LOCK EZ3	EA	32
3	18	PAFZZ	5305-00-984-6193	96906	MS35206-245	SCREW, MACHINE EZ3	EA	12
3	19	PAFZZ	5305-00-984-6194	96906	MS35206-246	SCREW, MACHINE EZ3	EA	14
3	20	XBOFF		80063	SC-D-972592	MOUNTING ASSEMBLY SEE FIGURE 2 AND FIG 3 FOR PARTS	EA	1
3	21	XBFZZ		80063	SC-B-972591	SPACER EZ3	EA	4
3	22	XBOFF		80063	SC-C-972589	BOX ASSEMBLY EZ3	EA	1
3	23	PAFZZ	5935-00-902-2344	96906	MS3124E12-10P	CONNECTOR, RECEPTACL EZ3	EA	1
3	24	PAFZZ		80063	SC-C-972590	BOX WELDMENT EZ3	EA	1
3	25	XBFZZ		80063	SC-B-972626	PLATE IDENT EZ3	EA	1
3	26	PAFZZ	5305-00-889-3118	96906	MS35206-203	SCREW, MACHINE EZ3	EA	2
3	27	PAFZZ	5310-00-934-9737	96906	MS35650-322	NUT, PLAIN, HEXAGON EZ3	EA	2
3	28	PAFZZ	5935-00-880-8890	96906	MS3124E16- 26PW	CONNECTOR, RECEPTACL EZ3	EA	1

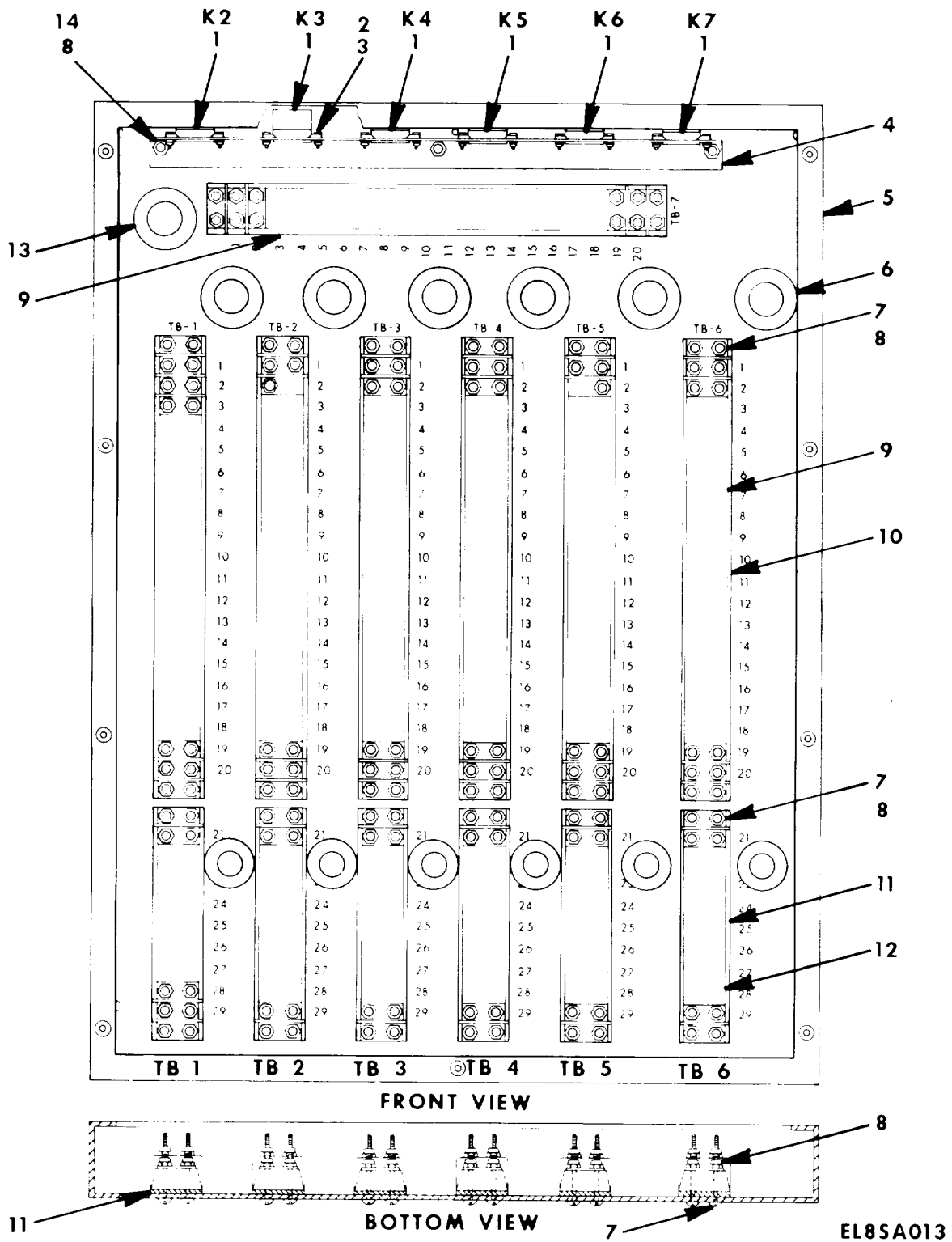
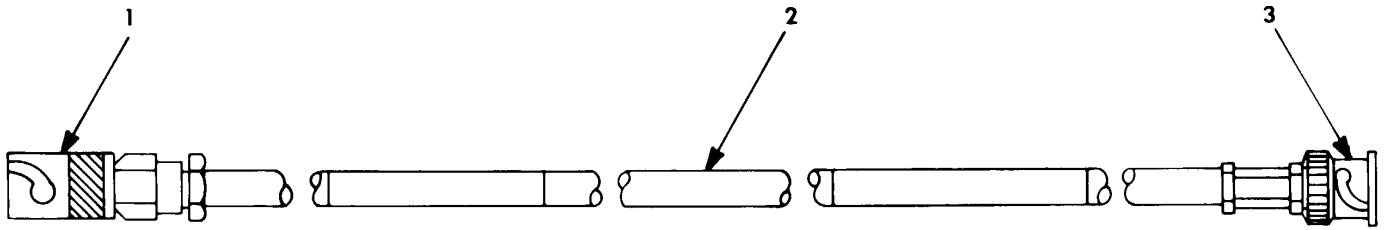

Figure 4. Box Assembly (Interphone Junction)

SECTION II

TM 11-5821-285-30P

(1) ILLUSTRATION		(2)	(3)	(4)	(5)	(6) DESCRIPTION	(7)	(8)
(a) FIG NO.	(b) ITEM NO.	SMR CODE	NATIONAL STOCK NUMBER	FSCM	PART NUMBER	USABLE ON CODE	U/M	QTY INC IN UNIT
						GROUP 03 BOX ASSEMBLY (INTERPHONE JUNCTION)		
4	1	PAFZZ	5945-01-052-6792	81349	439016/6-128M	RELAY,ELECTROMAGNE	EA	6
4	2	PAFZZ	5310-00-058-1823	96906	MS21042-02	NUT,SELF-LOCKING.EX.....	EA	12
4	3	PAFZZ	5305-00-988-1167	96906	MS35206-204	SCREW,MACHINE	EA	12
4	4	XBFZZ		80063	SC-C-972636	BRACKET RELAY	EA	1
4	5	XAFZZ		80063	SC-D-972612	BOX SUB ASSY	EA	1
4	6	PAFZZ	5325-00-276-6100	88044	AN931-8-13	GROMMET,NONMETALLIC	EA	6
4	7	PAFZZ	5305-00-984-4993	96906	MS35206-233	SCREW,MACHINE	EA	52
4	8	PAFZZ	5310-00-081-8087	96906	4521044N06	NUT,SELF-LOCKING,HE	EA	55
4	9	PAFZZ		80063	SC-B-972607	TERMINAL BOARD ASSY.....	EA	7
4	10	XBFZZ		80063	SC-8-972603	SPACER.....	EA	7
4	11	XBFZZ		80063	SC-B-972637	SPACER.....	EA	6
4	12	PAFZZ		80063	SC-B-972606	TERMINAL BOARD.....	EA	6
4	13	PAFZZ	5375-00-276-6091	88044	AN931-11-16	GROMMET,NONNETALLIC	EA	7
4	14	PAFZZ	5305-00-889-3000	96906	MS35206-230	SCREW,MACHINE	EA	3
					23			



ITEM NO.	FROM	TO	WIRE COLOR	AWG NO.	WIRE LG. INCHES
2	UG-1366/U	M39012/16-0004	COAX CABLE	RG58	52

EL85A014

Figure 5. Cable Assembly RF (ARC-164 Coax.).

SECTION II

TM 11-5821-285-30P

(1) ILLUSTRATION		(2)	(3)	(4)	(5)	(6)	(7)	(8)
(a) FIG NO.	(b) ITEM NO.	SMR CODE	NATIONAL STOCK NUMBER	FSCM	PART NUMBER	DESCRIPTION USABLE ON CODE	U/M	QTY INC IN UNIT
5	1	PAFZZ	5935-00-870-3632	81349	UG1366U	GROUP 04 CABLE ASSEMBLY RF (ARC-164 COAX)	EA	1
5	2	MFFZZ		80063	SC-C-972717-12	CONNECTOR PLUG	EA	FTV
5	3	PAFZZ		81349	M39012/16-0004	CABLE,RADIO FREQUEN MAKE FROM 6145-00-542-6092 CONNECTOR,PLUG,ELEC.....	EA	1
25								

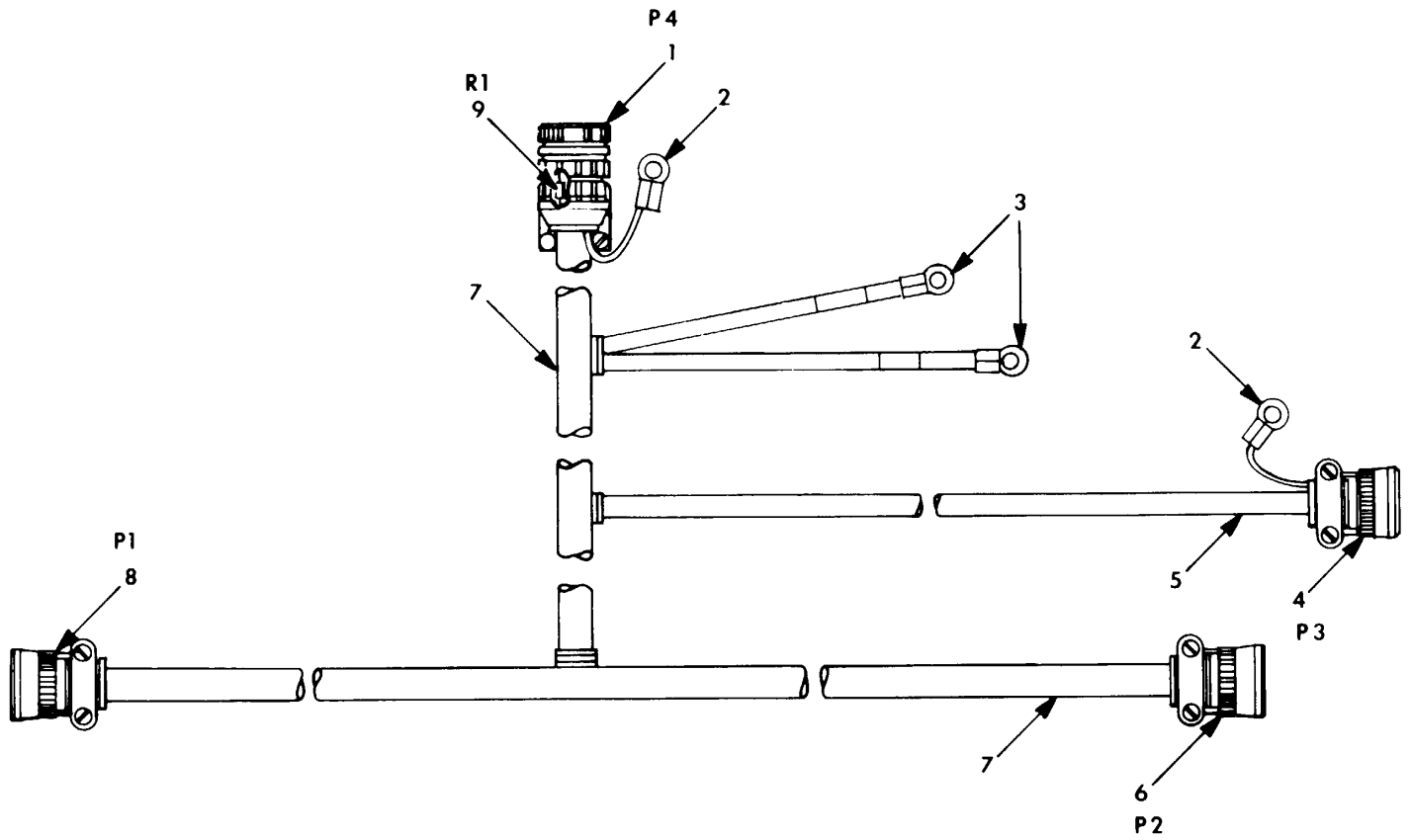

NOTE: PREFIX ALL REFERENCE DESIGNATIONS WITH A10W1.

EL85A015

Figure 6. Cable Assembly (Power and Control) (Sheet 1 of 3).

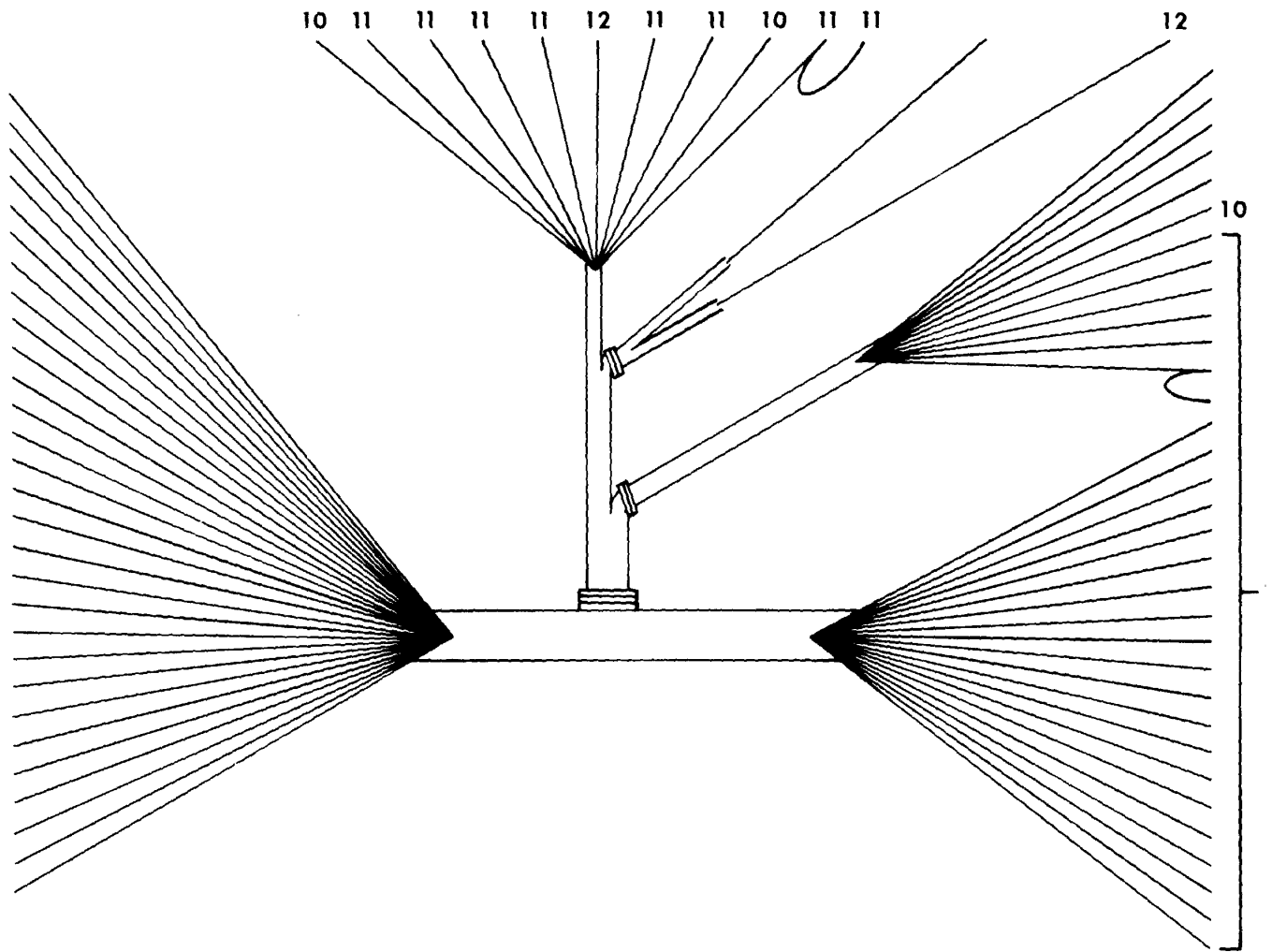

Figure 6. Cable Assembly (Power and Control) (Sheet 2 of 3).

ITEM NO	FROM	TO	WIRE COLOR	AWG NO	WIRE LG INCHES
10	A10W1P4-R	A10W1P1-F	SHD	20	69
11	A10W1P4-P	A10W1P1-P	WHT	20	69
11	A10W1P4-F	A10W1P1-L	WHT	20	69
11	A10W1P4-E	A10W1P1-N	WHT	20	69
11	A10WIP4-K	A10W1P3-P	WHT	20	55
12	A10WIP4-Q	FILTER INPUT	WHT	16	48
11	A10W1P4-C	A10W1P3-Y	WHT	20	55
11	A10W1P4-D	A10W1P3-D	WHT	20	52
10	A10W1P4-L	A101WP3-V	SHD	20	55
11	A10W1P4-G	CHASSIS GRD	WHT	20	6
12	FILTER OUTPUT	A10W1P3-A	WHT	16	52
10	A10W1P3-E	CHASSIS GRD	SHD	20	12
11	A10W1P3-U	CHASSIS GRD	WHT	20	12
11	A10W1P3-a	A10W1P1-H	WHT	20	49
11	A10W1P3-Z	A10W1P1-B	WHT	20	49
11	A10W1P3-R	A10W1P1-E	WHT	20	49
11	A10W1P3-T	A10W1P1-A	WHT	20	49
11	A10W1P3-C	A10W1P1-D	WHT	20	49
11	A10W1P2-E	A10W1P1-J	WHT	20	49
11	A10W1P2-F	A10W1P1-g	WHT	20	49
11	A10W1P2-H	A10W1P1-i	WHT	20	49
11	A10W1P2-J	A10W1P1-T	WHT	20	49
11	A10W1P2-K	A10W1P1-c	WHT	20	49
11	A10W1P2-L	A10W1P1-a	WHT	20	49
11	A10W1P2-M	A10W1P1-b	WHT	20	49
11	A10W1P2-N	A10W1P1-d	WHT	20	49
11	A10W1P2-P	A10W1P1-K	WHT	20	49
11	A10W1P2-R	A10W1P1-R	WHT	20	49
11	A10W1P2-S	A10W1P1-S	WHT	20	49
11	A10W1P2-T	A10W1P1-W	WHT	20	49
11	A10W1P2-U	A10W1P1-V	WHT	20	49
11	A10W1P2-V	A10W1P1-U	WHT	20	49
11	A10W1P2-X	A10W1P1-M	WHT	20	49
11	A10W1P2-Y	A10W1P1-f	WHT	20	49
11	A10W1P2-Z	A10W1P1-h	WHT	20	49
11	A10W1P2-a	A10W1P1-Y	WHT	20	49
11	A10W1P2-b	A10W1P1-Z	WHT	20	49
11	A10W1P2-c	A10W1P1-X	WHT	20	49
11	A10W1P3-A	A10W1P3-B	WHT	20	1
11	A10W1P3-Y	A10W1P3-X	WHT	20	1

EL8SA017

Figure 6. Cable Assembly (Power and Control) (Sheet 3 of 3).

SECTION II

TM 11-5821-285-30P

(1) ILLUSTRATION		(2)	(3)	(4)	(5)	(6)	(7)	(8)
(a) FIG NO.	(b) ITEM NO.	SMR CODE	NATIONAL STOCK NUMBER	FSCM	PART NUMBER	DESCRIPTION USABLE ON CODE	U/M	QTY INC IN UNIT
						GROUP 05 CABLE ASSEMBLY (POWER AND CONTROL)		
6	1	PAFZZ	5935-00-752-2979	96906	MS3106B28-16P	CONNECTOR,PLUG,ELEC.....	EA	1
6	2	PAFZZ	5940-00-557-1629	96906	MS25036-149	TERMINAL,LUG.....	EA	2
6	3	PAFZZ	5940-00-204-8966	96906	MS25036-102	TERMINAL,LUG.....	EA	2
6	4	PAFZZ	5935-00-480-6861	96906	MS3114F16-26S	CONNECTOR,RECEPTACL.....	EA	1
6	5	MFFZZ		80063	SC-D-972706-1Z	INSULATION SLEEVE MAKE FROM 5970-00-892-1020	FT	V
6	6	PAFZZ		96906	MS3114F16-26 SW	CONNECTER,RECEPTACL.....	EA	1
6	7	MFFZZ		80063	SC-D-972706-2	INSULATION SLEEVING MAKE FROM 5970-00-945-2849	FT	V
6	8	PAFZZ	5935-00-825-8864	96906	MS3112E18-32S	CONNECTOR,RECEPTACL.....	EA	1
6	9	PAFZZ	5905-00-108-6922	81349	RCR20G151JS	RESISTOR,FIXED,COMP.....	EA	1
6	10	MFFZZ		81349	M7078-2-20-1	CABLE,SPECIAL PURPO MAKE FROM 6145-00-191-3308		FTV
6	11	MFFZZ		80063	SC-D-972706-9	WIRE,ELECTRICAL MAKE FROM 6145-00-578-7519	FT	V
6	12	MFFZZ		80063	SC-D-972706-8	WIRE,ELECTRICAL MAKE FROM 6145-00-578-7517	FT	V
29/(30 blank)								

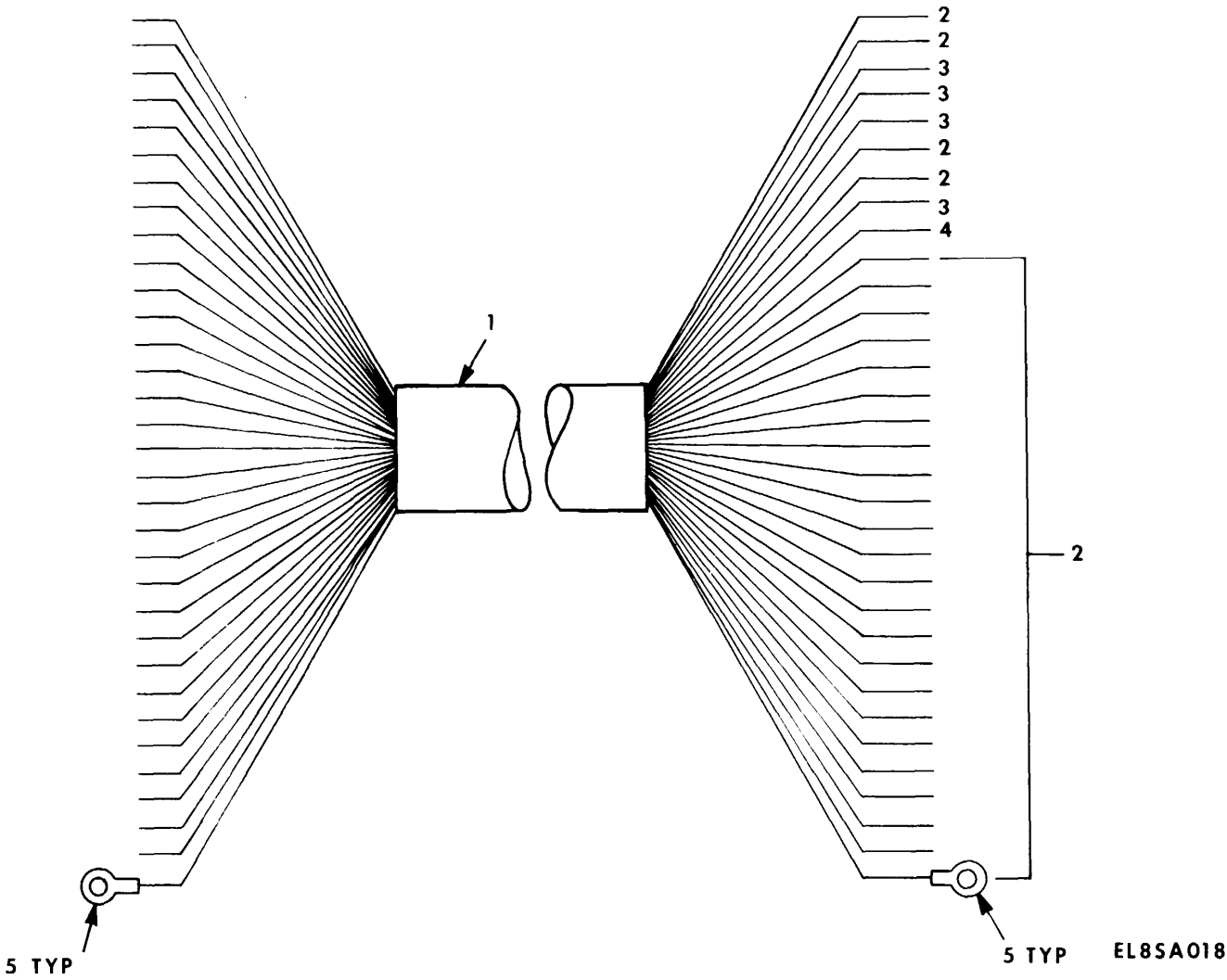

Figure 7. Cable Assembly (Junction Box) (Sheet 1 of 2).

ITEM NO	FROM	TO	WIRE COLOR	AWG NO	WIRE LG INCHES
2	TB-1(8)	TB-10(9)	SHD	20	108
2	TB-1(9)	TB-10(8)	SHD	20	108
3	TB-1(12)	TB-8(1)	WHT	20	108
3	TB-1(14)	TB-10(14)	WHT	20	108
3	TB-1(15)	TB-10(13)	WHT	20	108
2	TB-1(6)	TB-8(13)	SHD	20	108
2	TB-1(7)	TB-9(13)	SHD	20	108
3	TB-1(13)	TB-9(1)	WHT	20	108
4	TB-1(20)	CB-1	WHT	16	108
2	TB-1(2)	R-1	SHD	20	108
2	TB-1(3)	R-9	SHD	20	108
2	TB-1(5)	R-17	SHD	20	108
2	TB-1(4)	R-25	SHD	20	108
2	TB-2(2)	R-2	SHD	20	108
2	TB-2(3)	R-10	SHD	20	108
2	TB-2(5)	R-18	SHD	20	108
2	TB-2(4)	R-26	SHD	20	108
2	TB-3(2)	R-3	SHD	20	108
2	TB-3(3)	R-11	SHD	20	108
2	TB-3(5)	R-19	SHD	20	108
2	TB-3(4)	R-27	SHD	20	108
2	TB-4(2)	R-4	SHD	20	108
2	TB-4(3)	R-12	SHD	20	108
2	TB-4(5)	R-20	SHD	20	108
2	TB-4(4)	R-28	SHD	20	108
2	TB-5(2)	R-5	SHD	20	108
2	TB-5(3)	R-13	SHD	20	108
2	TB-5(5)	R-21	SHD	20	108
2	TB-5(4)	R-29	SHD	20	108
2	TB-6(2)	R-6	SHD	20	108
2	TB-6(3)	R-14	SHD	20	108
2	TB-6(5)	R-22	SHD	20	108
2	TB-6(4)	R-30	SHD	20	108

EL8SA019

Figure 7. Cable Assembly (Junction Box) (Sheet 2 of 2).

SECTION II

TM 11-5821-285-30P

(1) ILLUSTRATION		(2)	(3)	(4)	(5)	(6)	(7)	(8)
(a) FIG NO.	(b) ITEM NO.	SMR CODE	NATIONAL STOCK NUMBER	FSCM	PART NUMBER	DESCRIPTION USABLE ON CODE	U/M	QTY INC IN UNIT
						GROUP 06 CABLE ASSEMBLY (JUNCTION BOX)		
7	1	MFFZZ		80063	SC-D-972707-4	INSULATION SLEEVING MAKE FROM 5970-00-939-8942Z		FTV
7	2	MFFZZ		80063	SC-D-972707-1Z	CABLE SPECIAL PRP MAKE FROM 81349 MILW16878-4BGES9.....	FT	V
7	3	MFFZZ		80063	SC-D-972707-2	WIRE ELEC 20 AWG MAKE FROM 81349 MILW16878-4BGE9.....	FT	V
7	4	MFFZZ		80063	SC-D-972707-3	WIRE ELEC 16 AWG MAKE FROM 81349 MILW16878-4BJE9.....	FT	V
7	5	PAFZZ	5940-00-113-3138	96906	MS20659-102	TERMINAL,LUG	EA	66
					33			

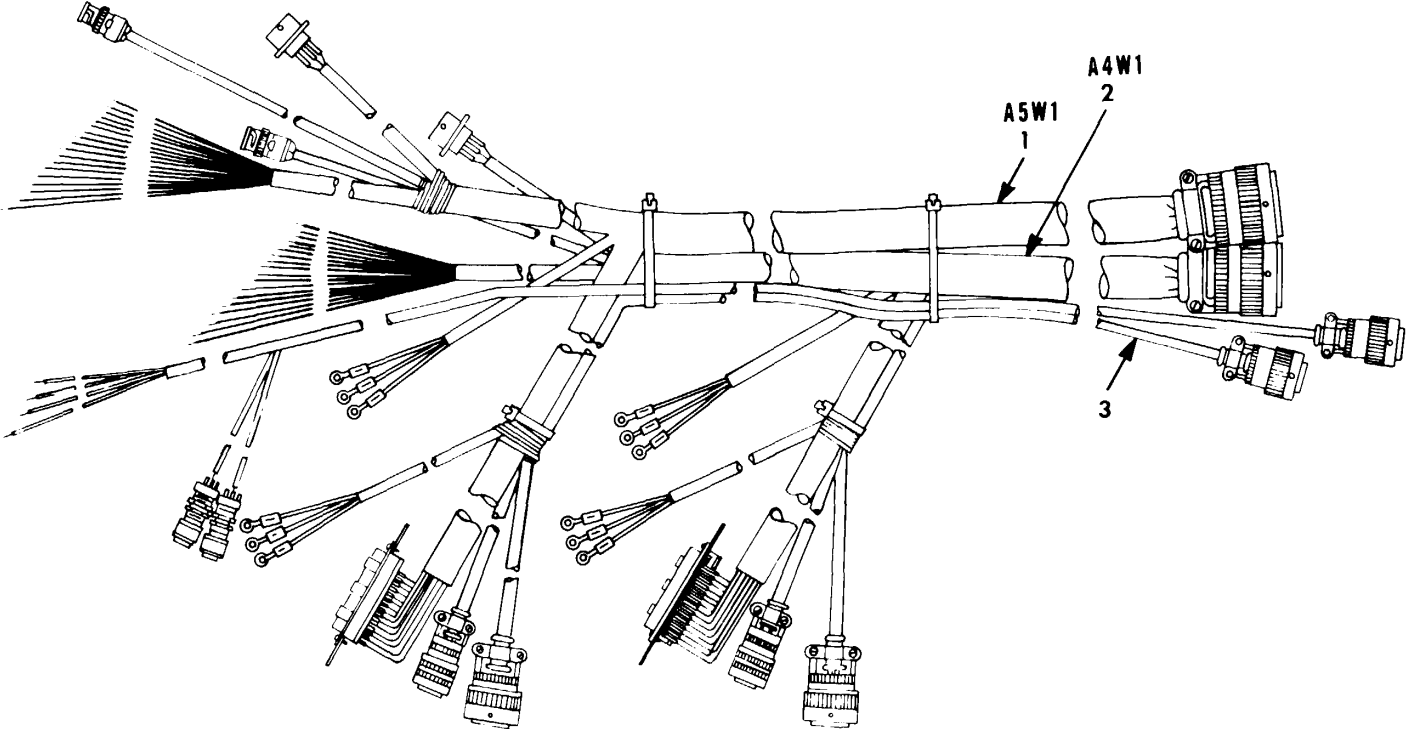

EL85A020

Figure 8. Control Cable Assembly (FM-1, FM-2, ARC-131 and KY-28) (Sheet 1 of 11).

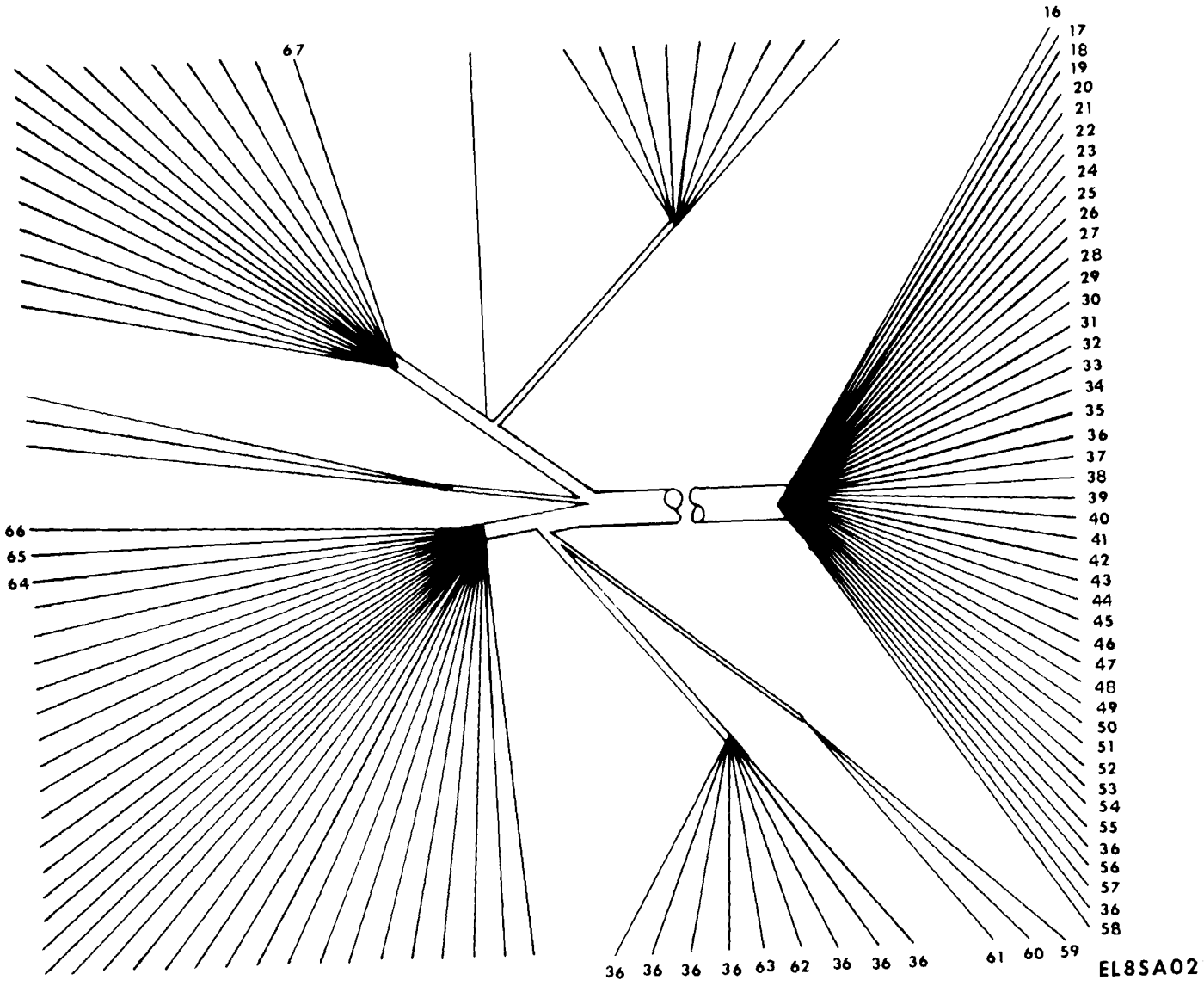

Figure 8. Control Cable Assembly (FM-1, FM-2, ARC-131 and KY-28) (Sheet 3 of 11).

ITEM NO	FROM	TO	WIRE COLOR	AWG NO	WIRE LG INCHES
16	A4W1P2-AA	A4W1P1-A	W/BK/O/GY	20	71 3/8
17	A4W1P2-z	A4W1P1-B	W/BK/Y/G	20	71 3/8
18	A4W1P2-j	A4W1P1-C	W/BK/Y/BL	20	71 3/8
19	A4W1P2-L	A4W1P1-D	W/BK/Y/V	20	71 3/8
20	A4W1P2-M	A4W1P1-E	W/BK/Y/GY	20	71 3/8
21	A4W1P2-H	A4W1P1-F	W/BK/G/BL	20	71 3/8
22	A4W1P2-g	A4W1P1-G	W/BK/G/V	20	71 3/8
23	A4W1P2-e	A4W1P1-J	W/BK/G/GY	20	71 3/8
24	A4W1P2-q	TB-8(1)	W/BK/BL/GY	20	97
25	A4W1P2-D	TB-8(4)	W/BK/V/GY	20	97 1/8
26	A4W1P2-C	TB-8(4)	W/BR/R/O	20	97 1/4
27	A4W1P2-E	TB-8(5)	W/BR/R/Y	20	97 3/8
28	A4W1P2-a	TB-8(6)	W/BR/R/G	20	97 1/2
29	A4W1P2-y	TB-8(7)	W/BR/R/BL	20	97 5/8
30	A4W1P2-N	TB-8(8)	W/BR/R/V	20	97 3/4
31	A4W1P2-KK	TB-8(9)	W/BR/R/GY	20	97 7/8
32	A4W1P2-b	TB-8(10)	W/BR/O/Y	20	98
33	A4W1P2-f	FILTER	W/BR/Y/G	20	49 7/8
34	A4W1P2-e	FILTER	W/BR/Y/BL	20	49 7/8
35	A4W1P2-F	FILTER	W/BR/Y/V	20	49 7/8
36	A4W1P2-x	A4W1P3-6	SHIELDED	20	58 1/4
37	A4W1P2-S	A4W1P3-35	W/BR/Y/GY	20	58 3/8
38	A4W1P2-K	A4W1P3-4	W/BR/G/BL	20	58 1/2
39	A4W1P2-i	A4W1P3-37	W/BR/G/V	20	58 5/8
40	A4W1P2-d	A4W1P3-5	W/BR/G/GY	20	58 3/4
41	A4W1P2-T	A4W1P3-22	W/BR/BL/V	20	58 7/8
42	A4W1P2-G	A4W1P3-23	W/BR/BL/GY	20	59
43	A4W1P2-CC	A4W1P3-24	W/BR/V/GY	20	59 1/8
44	A4W1P2-W	A4W1P3-8	W/R/O/Y	20	59 1/4
45	A4W1P2-v	A4W1P3-42	W/R/O/G	20	59 3/8
46	A4W1P2-BB	A4W1P3-25	W/R/O/BL	20	59 1/2
47	A4W1P2-X	A4W1P3-9	W/R/O/V	20	59 5/8
48	A4W1P2-k	A4W1P3-2	W/R/O/GY	20	59 3/4
49	A4W1P2-Y	A4W1P3-10	W/R/Y/G	20	59 7/8
50	A4WIP2-U	A4W1P3-27	W/R/Y/BL	20	60
51	A4W1P2-Z	A4W1P3-11	W/R/Y/V	20	60 1/8
52	A4W1P2-P	A4W1P3-28	W/R/Y/GY	20	60 1/4
53	A4W1P2-V	A4W1P3-12	W/R/G/BL	20	60 3/8
54	A4W1P2-J	A4W1P3-29	W/R/G/V	20	60 1/2
55	A4W1P2-LL	A4W1P3-30	W/R/G/GY	20	60 5/8
36	A4W1P2-JJ	A4W1P3-13	SHIELDED	20	60 3/4
56	A4W1P2-m	A4W1P3-31	W/R/BL/V	20	60 7/8
57	A4W1P2-h	A4W1P3-32	W/R/BL/GY	20	61
36	A4W1P2-B	A4W1P3-14	SHIELDED	20	61 1/8
58	A4W1P2-R	A4W1P3-33	W/R/V/GY	20	61 1/4
59	FILTER	A4W1P3-34	W/O/Y/G	20	20 1/8
60	FILTER	A4W1P3-18	W/O/Y/BL	20	20 1/4

EL8SA023

Figure 8. Control Cable Assembly (FM-1, FM-2, ARC-131 and KY-28) (Sheet 4 of 11).

ITEM NO	FROM	TO	WIRE COLOR	AWG NO	WIRE LG INCHES
61	FILTER	A4W1P3-36	W/O/Y/V	20	20 3/8
36	FM-1 P2-W	A4W1P3-39	SHIELDED	20	35 1/8
36	FM-1 P2-P	A4W1P3-7	SHIELDED	20	35 1/4
36	FM-1 P2-D	A4W1P3-15	SHIELDED	20	35 3/8
62	FM-1 P2-M	TB-8(1)	W/BR/O/G	20	87 1/8
63	FM-1 P1-K	TB-8(9)	W/BR/O/BL	20	87 1/4
36	FM-1 P1-A	TB-10(1)	SHIELDED	20	87 5/8
36	FM-1 P2-V	TB-8(7)	SHIELDED	20	87 3/4
36	FM-1 P2-G	TB-8(8)	SHIELDED	20	87 7/8
36	FM-1 P1-F	TB-8(13)	SHIELDED	20	88
64	A4W1P3-44	TB-8(1)	W/BR/O/V	20	75 7/8
65	A4W1P3-3	TB-8(12)	W/BR/O/GY	20	76
66	RT ANT	A4W1P4	COAX CABLE	RG58	65 1/2
67	TB-8(11)	A4W1P1-H	W/BK/BL/V	20	40 3/4

EL8SA024

Figure 8. Control Cable Assembly (FM-1, FM-2, ARC-131 and KY-28) (Sheet 5 of 11).

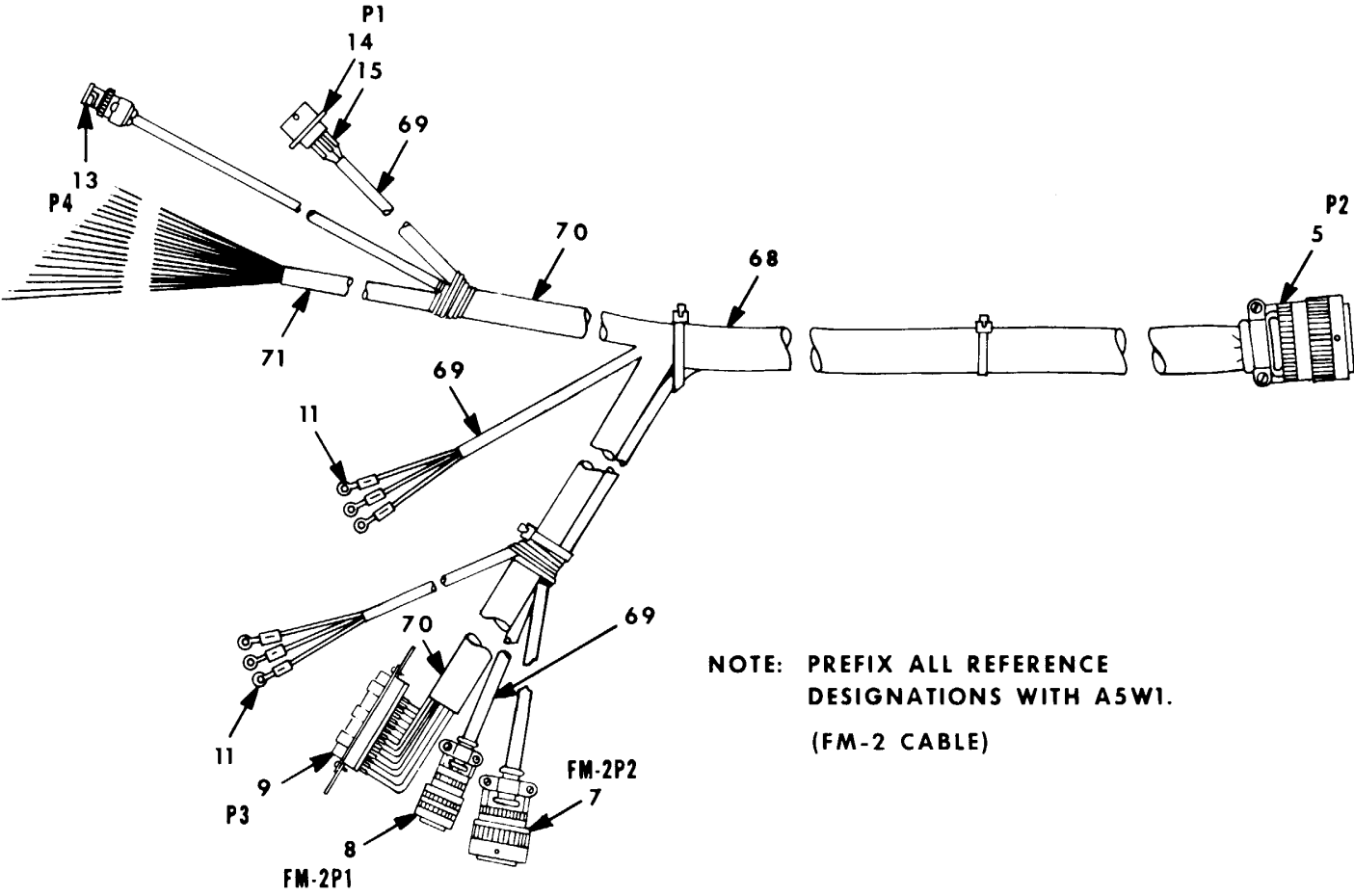

NOTE: PREFIX ALL REFERENCE DESIGNATIONS WITH A5W1.
(FM-2 CABLE)

EL85A025

Figure 8. Control Cable Assembly (FM-1, FM-2, ARC-131 and KY-28) (Sheet 6 of 11).

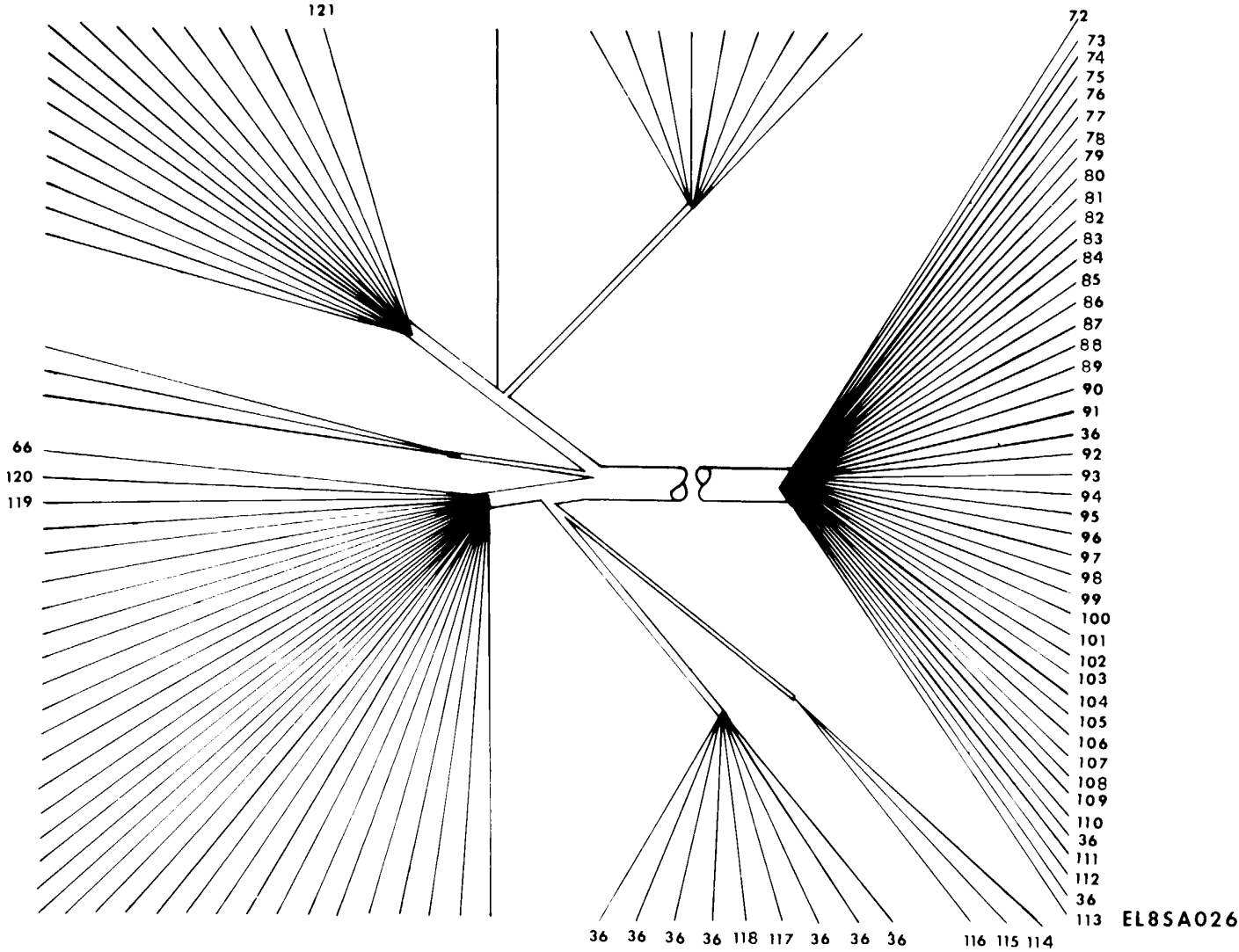

Figure 8. Control Cable Assembly (FM-1, FM-2, ARC-131 and KY-28) (Sheet 7 of 11).

ITEM NO	FROM	TO	WIRE COLOR	AWG NO	WIRE LG INCHES
72	A5W1P2-AA	A5W1P1-A	W/BK/Y	20	61 3/8
73	A5W1P2-z	A5W1P1-B	W/BK/G	20	61 3/8
74	A5W1P2-j	A5W1P1-C	W/BK/BL	20	61 3/3
75	A5W1P2-L	A5W1P1-D	W/BK/V	20	61 3/8
76	A5W1P2-M	A5W1P1-E	W/BK/GY	20	61 3/8
77	A5W1P2-H	A5W1P1-F	W/BR/RD	20	61 3/8
78	A5W1P2-g	A5W1P1-G	W/BR/O	20	61 3/8
79	A5W1P2-e	A5W1P1-J	W/BR/Y	20	61 3/8
80	A5W1P2-q	TB-9(1)	W/BR/BL	20	87
81	A5W1P2-D	TB-9(4)	W/BR/V	20	87 1/8
82	A5W1P2-C	TB-9(4)	W/BR/GY	20	87 1/4
83	A5W1P2-E	TB-9(5)	W/R/O	20	87 3/8
84	A5W1P2-a	TB-9(6)	W/R/Y	20	87 1/2
85	A5W1P2-y	TB-9(7)	W/R/G	20	87 5/8
86	A5W1P2-N	TB-9(8)	W/R/BL	20	87 3/4
87	A5W1P2-KK	TB-9(9)	W/R/V	20	87 7/8
88	A5W1P2-b	TB-9(10)	W/R/GY	20	88
89	A5W1P2-f	FILTER	W/Y/BL	20	39 7/8
90	A5W1P2-e	FILTER	W/Y/G	20	39 7/8
91	A5W1P2-F	FILTER	W/O/GY	20	39 7/8
36	A5W1P2-x	A5W1P3-6	SHIELDED	20	48 1/4
92	A5W1P2-S	A5W1P3-35	W/Y/V	20	48 3/8
93	A5W1P2-K	A5W1P3-4	W/Y/GY	20	48 1/2
94	A5W1P2-i	A5W1P3-37	W/G/BL	20	48 5/8
95	A5W1P2-d	A5W1P3-5	W/G/V	20	48 3/4
96	A5W1P2-T	A5W1P3-22	W/G/GY	20	48 7/8
97	A5W1P2-G	A5W1P3-23	W/BL/V	20	49
98	A5W1P2-CC	A5W1P3-24	W/BL/GY	20	49 1/8
99	A5W1P2-W	A5W1P3-8	W/V/GY	20	49 1/4
100	A5W1P2-v	A5W1P3-41	W/BK/BR/R	20	49 3/8
101	A5W1P2-BB	A5W1P3-25	W/BK/BR/O	20	49 1/2
102	A5W1P2-X	A5W1P3-9	W/BK/BR/Y	20	49 5/8
103	A5W1P2-k	A5W1P3-26	W/BK/BR/G	20	49 3/4
104	A5W1P2-Y	A5W1P3-10	W/BK/BR/BL	20	49 7/8
105	A5W1P2-U	A5W1P3-27	W/BK/BR/V	20	50
106	A5W1P2-Z	A5W1P3-11	W/BK/BR/GY	20	50 1/8
107	A5W1P2-P	A5W1P3-28	W/BK/R/O	20	50 1/4
108	A5W1P2-V	A5W1P3-12	W/BK/R/Y	20	50 3/8
109	A5W1P2-J	A5W1P3-29	W/BK/R/G	20	50 1/2
110	A5W1P2-LL	A5W1P3-30	W/BK/R/BL	20	50 5/8
36	A5W1P2-JJ	A5W1P3-13	SHIELDED	20	50 3/4
111	A5W1P2-m	A5W1P3-31	W/BK/R/V	20	50 7/8
112	A5W1P2-h	A5W1P3-32	W/BK/R/GY	20	51
36	A5W1P2-B	A5W1P3-14	SHIELDED	20	51 1/8
113	A5W1P2-R	A5W1P3-33	W/BK/O/Y	20	51 1/4
114	FILTER	A5W1P3-34	W/BK/O/G	20	20 1/8
115	FILTER	A5W1P3-18	W/BK/O/BL	20	20 1/4

EL8SA027

Figure 8. Control Cable Assembly (FM-1, FM-2, ARC-131 and KY-28) (Sheet 8 of 11).

ITEM NO	FROM	TO	WIRE COLOR	AWG NO	WIRE LG INCHES
116	FILTER	A5W1P3-36	W/BK/O/V	20	20 3/8
36	FM-2 P2-W	A5W1P3-39	SHIELDED	20	35 1/8
36	FM-2 P2-P	A5W1P3-7	SHIELDED	20	35 1/4
36	FM-2 P2-D	A5W1P3-15	SHIELDED	20	35 3/8
117	FM-2 P2-M	TB-9(1)	W/O/Y	20	87 1/8
118	FM-2 P1-K	TB-9(9)	W/O/G	20	87 1/4
36	FM-2 P1-A	TB-10(2)	SHIELDED	20	87 5/8
36	FM-2 P2-V	TB-9(7)	SHIELDED	20	87 3/8
36	FM-2 P2-G	TB-9(8)	SHIELDED	20	87 7/8
36	FM-2 P1-F	TB-9(13)	SHIELDED	20	88
119	A5W1P3-44	TB-9(1)	W/O/BL	20	75 7/8
120	A5W1P3-3	TB-9(12)	W/O/V	20	76
66	RT ANT	A5W1P4	COAX CA	RG58	65 1/2
121	TB-9(11)	A5W1P1-H	W/BR/G	20	40 3/4

EL8SA028

Figure 8. Control Cable Assembly (FM-1, FM-2, ARC-131 and KY-28) (Sheet 9 of 11).

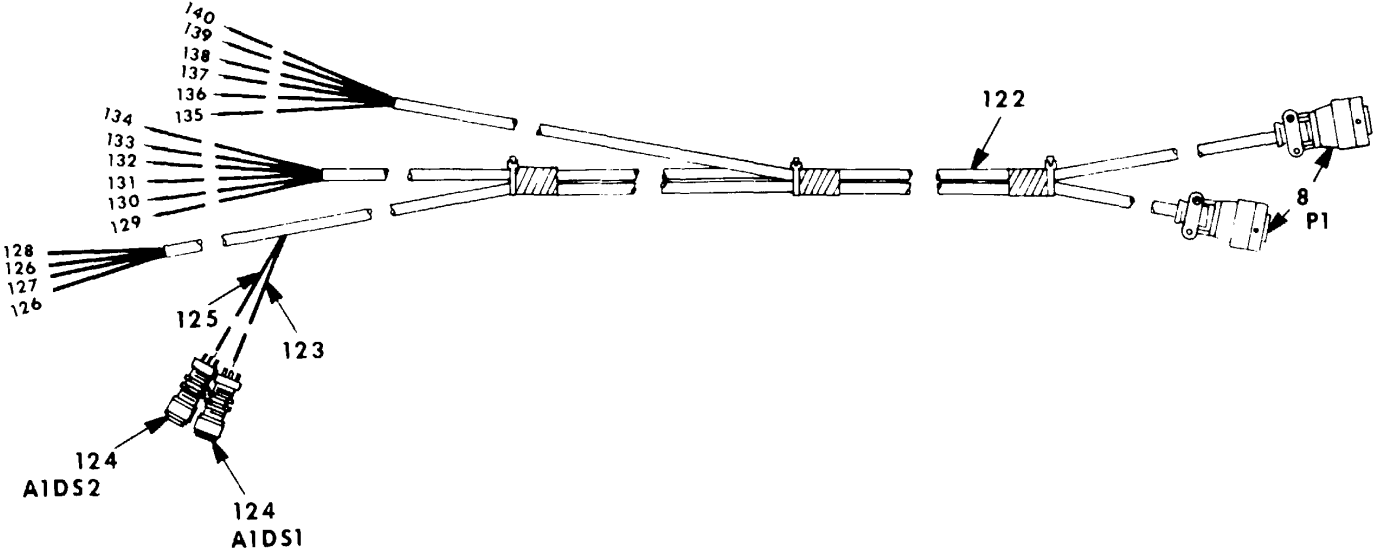

EL85A029

Figure 8. Control Cable Assembly (FM-1, FM-2, ARC-131 and KY-28) (Sheet 10 of 11).

ITEM NO	FROM	TO	WIRE COLOR	AWG NO	WIRE LG INCHES
123	FM-1 SCTY IND LAMP	C-8157#1 P1-G	WHT/BLK/ORN	20	93
125	FM-2 SCTY IND LAMP	C-8157#2 P1-G	WHT/GRN	20	101 1/4
126	CHASSIS GRD	C-8157#1 P1-E	BLK	18	92 1/4
127	TB-10(18)	C-8157#1 P1-A	YEL	18	92 1/4
126	CHASSIS GRD	C-8157#2 P1-E	BLK	18	100 1/4
128	TB-10(18)	C-8157#2 P1-A	RED	20	100 1/4
129	FM-1 P2-Y	C-8157#1 P1-K	WHT/BLK/RED	20	77 1/2
130	FM-1 P2-Z	C-8157#1 P1-J	WHT/BLK/BRN	20	77 1/2
131	FM-1 P2-H	C-8157#1 P1-C	WHT/GRY	20	77 1/2
132	FM-1 P2-R	C-8157#1 P1-D	WHT/VIO	20	77 1/2
133	FM-1 P2-K	C-8157#1 P1-F	WHT/BLU	20	77 1/2
134	FM-1 P2-J	C-8157#1 P1-B	ORN	18	77 1/2
135	FM-2 P2-Y	C-8157#2 P1-K	WHT/YEL	20	75
136	FM-2 P2-Z	C-8157#2 P1-J	WHT/ORG	20	75
137	FM-2 P2-H	C-8157#2 P1-C	WHT/RED	20	75
138	FM-2 P2-R	C-8157#2 P1-D	WHT/BRN	20	75
139	FM-2 P2-K	C-8157#2 P1-F	WHT/BLK	20	75
140	FM-2 P2-J	C-8157#2 P1-B	BRN	18	75

EL8SA030

Figure 8. Control Cable Assembly (FM-1, FM-2, ARC-131 and KY-28) (Sheet 11 of 11).

SECTION II

TM 11-5821-285-30P

(1) ILLUSTRATION		(2)	(3)	(4)	(5)	(6)	(7)	(8)
(a) FIG NO.	(b) ITEM NO.	SMR CODE	NATIONAL STOCK NUMBER	FSCM	PART NUMBER	DESCRIPTION USABLE ON CODE	U/M	QTY INC IN UNIT
						GROUP 07 CONTROL CABLE ASSEMBLY (FM-1, FM-2,ARC-131 AND KY-287		
8	1	AFFFF		80063	SC-D-972715	CABLE ASSEMBLY.....	EA	1
8	2	AFFFF		80063	SC-D-972714	CABLE ASSEMBLY.....	EA	1
8	3	AFFFF		80063	SC-D-972712	CABLE ASSEMBLY.....	EA	1
8	4	MFFZZ	5935-00-892-9894	80063	SC-D-972714-4	INSULATION SLEEVE MAKE FROM 5970-00-892-0986	FT	V
8	5	PAFZZ		96906	MS3116E24-61S	CONNECTOR,PLUG,ELEC.....	EA	2
8	6	MFFZZ		80063	SC-D-972714-5	INSULATION SLEEVE MAKE FROM 5970-01-094-0479	FT	V
8	7	PAFZZ		96906	MS3476F16-26S	CONNECTOR,PLUG,ELEC.....	EA	2
8	9	PAFZZ		96906	MS3476F12-10S	CONNECTOR,PLUG,ELEC.....	EA	2
8	9	PAFZZ	5935-00-089-8052	37695	709299-801	CONNECTOR KIT ASSEM.....	EA	2
8	10	MFFZZ		80063	SC-D-972712-2	INSULATION SLEEVE MAKE FROM 5970-00-892-1020	FT	V
8	11	PAFZZ	5940-00-113-3138	96906	MS20659-102	TERMNINAL,LUG.....	EA	12
8	12	MFFZZ		80063	SC-D-972714-3	INSULATION SLEEVE MAKE FROM 5970-00-681-9774	FT	V
8	13	PAFZZ	5935-01-043-0629	81349	M39012/16-0101	CONNECTOR,PLUG,ELEC.....	EA	2
8	14	PAFZZ	5935-00-826-1020	96906	MS3112E12-10S	CONNECTOR,RECEPTAC.....	EA	2
8	15	MFFZZ		80063	SC-D-972708-13	INSULATION SLEEVING MAKE FROM 5970-00-945-2849	FT	V
8	16	MFFZZ		80063	SC-D-972714-1B	WIRE ELEC 20 AWG MAKE FROM 81349 MWC20-7J9038	FTV	
8	17	MFFZZ		80063	SC-D-972714-1C	WIRE ELEC 20 AWG MAKE FROM 81349 MWC20-7J9045	FTV	
8	18	MFFZZ		80063	SC-D-972714-1D	WIRE ELEC 20 AWG MAKE FROM 81349 MWC20-7J9046	FTV	
8	19	MFFZZ		80063	SC-D-972714-1E	WIRE ELEC 20 AWG MAKE FROM 81349 MWC20-7J9047	FTV	
8	20	MFFZZ		80063	SC-D-972714-1F	WIRE ELEC 20 AWG MAKE FROM 81349 MWC20-7J9048	FTV	
8	21	MFFZZ		80063	SC-D-972714-1G	WIRE FLEC 20 AWG MAKE FROM 81349 MWC20-7J9056	FTV	
8	22	MFFZZ		80063	SC-D-972714-1H	WIRE ELEC 20 AWG MAKE FROM 8L349 MWC20-7J9057	FTV	
8	23	MFFZZ		80063	SC-D-972714-1A	WIRE ELEC 20 AWG MAKE FROM 81349 MWC20-7J9058	FTV	
8	24	MFFZZ		80063	SC-D-972714-1K	WIRE ELEC 20 AWG MAKE FROM 81349 MWC20-7J9068	FTV	
8	25	MFFZZ		80063	SC-D-972714-1L	WIRE ELEC 20 AWG MAKE FROM 81349 MWC20-7J9078	FTV	
8	26	MFFZZ		80063	SC-O-972714-1M	WIRE ELEC 20 AWG MAKE FROM 81349 MWC20-7J9123	FTV	
8	27	MFFZZ		80063	SC-D-972714-1N	WIRE ELEC 20 AWG MAKE FROM 81349 MWC20-7J9124	FTV	
8	28	MFFZZ		80063	SC-D-972714-1P	WIRE ELEC 20 AWG MAKE FROM 81349 MWC20-7J9125	FTV	
8	29	MFFZZ		80063	SC-D-972714-1Q	WIRE ELEC 20 AWG MAKE FROM 81349 MWC20-7J9126	FTV	
8	30	MFFZZ		80063	SC-D-972714-1R	WIRE ELEC 20 AWG MAKE FROM 81349 MWC20-7J9127	FTV	
8	31	MFFZZ		80063	SC-D-972714-1S	WIPE ELEC 20 AWG MAKE FROM 81349 MWC20-7J9128	FTV	
8	32	MFFZZ		80063	SC-D-972714-1T	WIRE ELEC 20 AWG MAKE FROM 81349 MWC20-7J9134	FTV	
8	33	MFFLZZ		80063	SC-D-972714-1Y	WIRE ELEC 20 AWG MAKE FROM 81349 MWC20-7J9145	FTV	
8	34	MFFZZ		80063	SC-D-972714-1Z	WIRE ELEC 20 AWG MAKE FROM 81349 MWC20-7J9146	FTV	
8	35	MFFZZ		80063	SC-D-972714-1ZA	WIRE ELEC 20 AWG MAKE FROM 81349 MWC20-7J9147	FTV	
8	36	MFFZZ		80063	SC-D-972714-2A	CABLE SPECIAL PRP MAKE FROM 81349 MWC20-7JS9	FT	V
8	37	MFFZZ		80063	SC-D-972714-1ZB	WIRE ELEC 20 AWG MAKE FROM 81349 MWC20-7J9148	FTV	
8	38	MFFZZ		80063	SC-D-972714-1ZC	WIRE ELEC 20 AVG MAKE FROM 81349 MWC20-7J9156	FT	V

SECTION II

TM 11-5821-285-30P

(1) ILLUSTRATION		(2)	(3)	(4)	(5)	(6)	(7)	(8)
(a) FIG NO.	(b) ITEM NO.	SMR CODE	NATIONAL STOCK NUMBER	FSCM	PART NUMBER	DESCRIPTION USABLE ON CODE	U/M	QTY INC IN UNIT
8	39	MFFZZ		80063	SC-D-972714-1ZD	WIRE ELEC 20 AWG MAKE FROM 81349 MWC20-7J9157		FTV
8	40	MFFZZ		80063	SC-D-972714-1ZE	WIRE ELEC 20 AWG MAKE FROM 81349 MWC20-7J9158		FTV
8	41	MFFZZ		80063	SC-D-972714-1ZF	WIRE ELEC 20 AWG MAKE FROM 81349 MWC20-7J9167	FT	V
8	42	MFFZZ		80063	SC-D-972714-1ZG	WIRE ELEC 20 AWG MAKE FROM 81349 MWC20-7J9168		FTV
8	43	MFFZZ		80063	SC-D-972714-1ZH	WIRE ELEC 20 AWG MAKE FROM 81349 MWC20-7J9178		FTV
8	44	MFFZZ		80063	SC-D-972714-1ZJ	WIRE ELEC 20 AWG MAKE FROM 81349 MWC20-7J9234		FTV
8	45	MFFZZ		80063	SC-D-972714-1ZK	WIRE ELEC 20 AWG MAKE FROM 81349 MWC20-7J9235		FTV
8	46	MFFZZ		80063	SC-D-972714-1ZL	WIRE ELEC 20 AWG MAKE FROM 81349 MWC20-7J9236		FTV
8	47	MFFZZ		80063	SC-D-972714-1ZM	WIRE ELEC 20 AWG MAKE FROM		FTV
81349	MWC20-7J9237			FT	V			
8	48	MFFZZ		80063	SC-D-972714-1ZN	WIRE ELEC 20 AWG MAKE FROM 81349 MWC20-7J9238		FTV
8	49	MFFZZ		80063	SC-D-972714-1ZP	WIRE ELEC 20 AWG MAKE FROM 81349 MWC20-7J9245		FTV
8	50	MFFZZ		80063	SC-D-972714-1ZQ	WIRE ELEC 20 AWG MAKE FROM 81349 MWC20-7J9246		FTV
8	51	MFFZZ		80063	SC-D-972714-1ZR	WIRE ELEC 20 AWG MAKE FROM 81349 MWC20-7J9247	FT	V
8	52	MFFZZ		80063	SC-D-972714-1ZS	WIRE ELEC 20 AWG MAKE FROM 81349 MWC20-7J9248		FTV
8	53	MFFZZ		80063	SC-D-972714-1ZT	WIRE ELEC 20 AWG MAKE FROM 81349 MWC20-7J9256	FT	V
8	54	MFFZZ		80063	SC-D-972714-1ZU	WIRE ELEC 20 AWG MAKE FROM 81349 MWC20-7J9257		FTV
8	55	MFFZZ		80363	SC-D-972714-1ZV	WIRE ELEC 20 AWG MAKE FROM 81349 MWC20-7J9258		FTV
8	56	MFFZZ		80063	SC-D-972714-1ZW	WIRE ELEC 20 AWG MAKE FROM 81349 MWC20-7J9267		FTV
8	57	MFFZZ		80063	SC-D-972714-1ZX	WIRE ELEC 20 AWG MAKE FROM 81349 MWC20-7J9268		FTV
8	58	MFFZZ		80063	SC-D-972714-1ZY	WIRE ELEC 20 AWG MAKE FROM 81349 MWC20-7J9278		FTV
8	59	MFFZZ		80063	SC-D-972714-1ZZZ	WIRE ELEC 20 AWG MAKE FROM 81349 MWC20-7J9345		FTV
8	60	MFFZZ		80063	SC-D-972714-1Z1	WIRE ELEC 20 AWG MAKE FROM 81349 MWC20-7J9346		FTV
8	61	MFFZZ		80063	SC-D-972714-1Z2	WIRE ELEC 20 AWG MAKE FROM 81349 MWC20-7J9347		FTV
8	62	MFFZZ		80063	SC-D-972714-1U	WIRE ELEC 20 AWG MAKE FROM 81349 MWC20-7J9135		FTV
8	63	MFFZZ		80063	SC-D-972714-1V	WIRE ELEC 20 AWG MAKE FROM 81349 MWC20-7J9136		FTV
8	64	MFFZZ		80063	SC-D-972714-1W	WIRE ELEC 20 AWG MAKE FROM 81349 MWC20-7J9137		FTV
8	65	MFFZZ		80063	SC-D-972714-1X	WIPE ELEC 20 AWG MAKE FROM 81349 MWC20-7J9138		FTV
8	66	MFFZZ		80063	SC-D-972714-1	CABLE RF MAKE FROM 81349 RG58U	FT	V
8	67	MFFZZ		80063	SC-D-972714-1J	WIRE ELEC 20 AWG MAKE FROM 81349 MWC20-7J9067		FTV
8	68	MFFZZ		80063	SC-D-972715-4	INSULATION SLEEVE MAKE FROM 5970-00-892-0986	FT	V
8	69	MFFZZ		80063	SC-D-972715-5	INSULATION SLEEVE MAKE FROM 5910-01-094-0479	FT	V
8	70	MFFZZ		80063	SC-D-972715-2	INSULATION SLEEVE MAKE FROM 5970-00-892-1020	FT	V

SECTION II

TM 11-5821-285-30P

(1) ILLUSTRATION		(2)	(3)	(4)	(5)	(6)	(7)	(8)
(a) FIG NO.	(b) ITEM NO.	SMR CODE	NATIONAL STOCK NUMBER	FSCM	PART NUMBER	DESCRIPTION USABLE ON CODE	U/M	QTY INC IN UNIT
8	71	MFFZZ		80063	SC-D-972715-3	INSULATION SLEEVE MAKE FROM 5970-00-681-9774	FT	V
8	72	MFFZZ		80063	SC-D-972715-15	WIRE ELEC 20 AWG MAKE FROM 81349 MWC20-7J904	FT	V
8	73	MFFZZ		80063	SC-D-972715-1T	WIRE ELEC 20 AWG MAKE FROM 81349 MWC20-7J905	FT	V
8	74	MFFZZ		80063	SC-D-972715-1U	WIRE,ELECTRICAL MAKE FROM 81349 MWC20-J906	FT	V
8	75	MFFZZ		80063	SC-D-972715-1V	WIRE ELEC 20 AWG MAKE FROM 81349 MWC20-7J907	FT	V
8	76	MFFZZ		8D063	SC-D-972715-1W	WIRE ELEC 20 AWG MAKE FROM 81349 MWC20-7J908	FT	V
8	77	MFFZZ		80063	SC-D-972715-1X	WIRE,ELECTRICAL MAKE FROM 81349 MWC20-7J912-	FT	V
8	78	MFFZZ		80063	SC-D-972715-1Y	WIRE ELEC 20 AWG MAKE FROM 81349 MWC20-7J913	FT	V
8	79	MFFZZ		80063	SC-0-972715-1Z	WIRE ELEC 20 AWG MAKE FROM 81349 MWC20-7J914	FT	V
8	80	MFFZZ		80063	SC-D-972715-1ZB	WIRE ELEC 20 AWG MAKE FROM 81349 MWC20-7J916	FT	V
8	81	MFFZZ		80063	SC-D-972715-1ZC	WIRE ELEC 20 AWG MAKE FROM 81349 MWC20-JJ917	FT	V
8	82	MFFZZ		80063	SC-D-972715-1ZD	WIRE ELEC 20 AWG MAKE FROM 81349 MWC20-7J918	FT	V
8	83	MFFZZ		80063	SC-D-972715-1ZE	WIRE ELEC 20 AWG M4AKE FROM 81349 MWC20-7J923		FTV
8	84	MFFZZ		80063	SC-D-972715-1ZF	WIRE,ELECTRICAL MAKE FROM 81349 MWC20-7J924	FT	V
8	85	MFFZZ		80063	SC-D-972715-1ZG	WIRE,ELECTRRICAL MAKE FROM 81349 MWC20-TJ925	FT	V
8	86	MFFZZ		80063	SC-D-972715-1ZH	WIRE,ELECTRICAL MAKE FROM 81349 MWC20-7J926	FT	V
8	87	MFFZZ		80063	SC-D-972715-1ZJ	WIRE ELEC 20 AWG MAKE FROM 81349 MWC20-7J927	FT	V
8	88	MFFZZ		80063	SC-D-972715-1ZK	WIRE ELEC 20 AWG MAKE FROM 81349 MWC20-7J928	FT	V
8	89	MFFZZ		80063	SC-D-972715-1ZS	WIRE,ELECTRICAL MAKE FROM 81349 MWC20-7J946	FT	V
8	90	MFFZZ		80063	SC-D-972715-1ZR	WIRE ELEC 20 AWG MAKE FROM 81349 MWC20-7J945	FT	V
8	91	MFFZZ		80063	SC-D-972715-1ZQ	WIRE ELEC 20 AWG MAKE FROM 81349 MWC20-7J938	FT	V
8	92	MFFZZ		80063	SC-D-972715-1ZT	WIRE ELEC 20 AWG MAKE FROM 81349 MWC20-7J947	FT	V
8	93	MFFZZ		80063	SC-D-972715-1ZU	WIRE ELEC 20 AWG MAKE FROM 81349 MWC2Z-7J948	FT	V
8	94	MFFZZ		80063	SC-D-972715-1ZV	WIRE,ELECTRICAL MAKE FROM 81349 MWC20-7J956	FT	V
8	95	MFFZZ		80063	SC-D-972715-1Z3	WIRE ELEC 20 AWG MAKE FROM 81349 MWC20-7J957	FT	V
8	96	MFFZZ		80063	SC-D-972715-1ZW	WIRE ELEC 20 AWG MAKE FROM 81349 MWC20-7J958	FT	V
8	97	MFFZZ		80063	SC-D-972715-1ZX	WIRE ELEC 20 AWG MAKE FROM 81349 MWC20-7J967	FT	V
8	98	MFFZZ		80063	SC-D-972715-1ZY	WIRE ELEC 20 AWG MAKE FROM 81349 MWC20-7J968	FT	V
8	99	MFFZZ		80063	SC-D-972715-1ZZ	WIRE ELEC 20 AWG MAKE FROM 81349 MWC2 0-7J978	FT	V
8	100	MFFZZ		80063	SC-D-972715-1A	WIRE ELEC 20 AWG MAKE FROM 81349 MWC2 0-7J9012	FT	V
8	101	MFFZZ		80063	SC-D-972715-1B	WIRE ELEC 20 AWG MAKE FROM 81349 MWC20-7J9013		FTV
8	102	MFFZZ		80063	SC-D-972715-1C	WIRE ELEC 20 AWG MAKE FROM 81349 MWC20-7J9014		FTV

SECTION II

TM 11-5821-285-30P

(1) ILLUSTRATION		(2)	(3)	(4)	(5)	(6)	(7)	(8)
(a) FIG NO.	(b) ITEM NO.	SMR CODE	NATIONAL STOCK NUMBER	FSCM	PART NUMBER	DESCRIPTION USABLE ON CODE	U/M	QTY INC IN UNIT
8	103	MFFZZ		80063	SC-D-972715-1D	WIRE ELEC 20 AWG MAKE FROM 81349 MWC20-7J9015		FTV
8	104	MFFZZ		80063	SC-D-972715-1E	WIRE ELEC 20 AWG MAKE FROM 81349 MWC20-7J9016		FTV
8	105	MFFZZ		80063	SC-D-972715-1F	WIRE ELEC 20 AWG MAKE FROM 81349 MWC20-7J9017		FTV
8	106	MFFZZ		80063	SC-D-972715-1G	WIRE ELEC 20 AWG MAKE FROM 81349 MWC20-7J9018		FTV
8	107	MFFZZ		80063	SC-D-972715-1H	WIPE ELEC 20 AWG MAKE FROM 81349 MWC20-7J9023		FTV
8	108	MFFZZ		80063	SC-D-972715-1J	WIRE ELEC 20 AWG MAKE FROM 81349 MWC20-7J9024		FTV
8	109	MFFZZ		80063	SC-D-972715-1K	WIRE ELEC 20 AWG MAKE FROM 81349 MWC20-7J9025		FTV
8	110	MFFZZ		80063	SC-D-972715-1L	WIRE ELEC 20 AWG MAKE FROM 81349 MWC20-7J9026		FTV
8	111	MFFZZ		80063	SC-D-972715-1M	WIRE ELEC 20 AWG MAKE FROM 81349 MWC20-7J9027		FTV
8	112	MFFZZ		80063	SC-D-972715-1N	WIRE ELEC 20 AWG MAKE FROM 81349 MWC20-7J9028		FTV
8	113	MFFZZ		80063	SC-D-972715-1P	WIRE ELEC 20 AWG MAKE FROM 81349 MWC20-7J9034		FTV
8	114	MFFZZ		80063	SC-D-972715-121	WIRE ELEC 20 AWG MAKE FROM 81349 MWC20-7J9035		FTV
8	115	MFFZZ		80063	SC-D-972715-1Q	WIPE ELEC 20 AWG MAKE FROM 81349 MWC20-7J9036		FTV
8	116	MFFZZ		80063	SC-D-972715-1R	WIRE ELEC 20 AWG MAKE FROM 81349 MWC20-7J9037		FTV
8	117	MFFZZ		80063	SC-D-972715-1ZL	WIRE ELEC 20 AWG MAKE FROM 81349 MWC20-7J934	FT	V
8	118	MFFZZ		80063	SC-D-972715-1ZM	WIRE,ELECTRICAL MAKE FROM 81349 MWC20-7J935	FT	V
8	119	MFFZZ		80063	SC-D-972715-1ZN	WIRE,ELECTRICAL MAKE FROM 81349 MWC20-7J936	FT	V
8	120	MFFZZ		80063	SC-D-972715-1ZP	WIRE ELEC 20 AWG MAKE FROM 81349 MWC20-7J937	FT	V
8	121	MFFZZ		80063	SC-D-972715-1ZA	WIRE ELEC 20 AWG MAKE FROM 81349 MWC20-7J915	FT	V
8	122	MFFZZ		80063	SC-D-972712-5	INSULATION SLEEVING MAKE FROM 5970-00-948-6660		FTV
8	123	MFFZZ		80063	SC-D-972712-4D	WIRE ELEC 20 AWG MAKE FROM 81349 M5086/1-20-903		FTV
8	124	PAFZZ	6210-00-538-8770	96906	MS25041-3	LIGHT,INDICATOR.....	EA	2
8	125	MFFZZ		80063	SC-D-972712-4H	WIRE ELEC 20 AWG MAKE FROM 81349 M5086/1-20-95	FT	V
8	126	MFFZZ		80063	SC-D-972712-3A	WIRE ELEC 18 AWG MAKE FROM 81349 M5086/1-18-0	FT	V
8	127	MFFZZ		80063	SC-D-972712-3E	WIRE ELEC 18 AWG MAKE FROM 81349 M5086/1-18-4	FT	V
8	128	MFFZZ		80063	SC-D-972712-3C	WIPE ELEC 18 AWG MAKE FROM 81349 M5086/1-18-2	FT	V
8	129	MFFZZ		80063	SC-D-972712-4C	WIRE ELEC 20 AWG MAKE FROM 81349 M5086/1-20-902		FTV
8	130	MFFZZ		80063	SC-D-972712-4B	WIRE ELEC 20 AWG MAKE FROM 81349 M5086/1-20-901		FTV
8	131	MFFZZ		80063	SC-D-972712-4J	WIRE ELEC 20 AWG MAKE FROM 81349 M5086/1-20-98	FT	V
8	132	MFFZZ		80063	SC-D-972712-4L	WIRE ELEC 20 AWG MAKE FROM 81349 M5086/1-20-97	FT	V
8	133	MFFZZ		80063	SC-D-972712-4K	WIRE ELEC 20 AWG MAKE FROM 81349 M5086/1-20-96	FT	V
8	134	MFFZZ		80063	SC-D-972712-3D	WIRE ELEC 18 AWG MAKE FROM 81349 M5086/1-18-3	FT	V
8	135	MFFZZ		80063	SC-D-972712-4G	WIRE ELEC 20 AWG MAKE FROM 81349 M5086/1-20-94	FT	V
8	136	MFFZZ		80063	SC-D-972712-4M	WIPE ELEC 20 AWG MAKE FROM 81349 M5086/1-20-93	FT	V
8	137	MFFZZ		80063	SC-D-972712-4F	WIRE ELEC 20 AWG MAKE FROM 81349 M5086/1-20-92	FT	V
8	138	MFFZZ		80063	SC-D-972712-4E	WIRE ELEC 20 AWG MAKE FROM 81349 M5086/1-20-91	FT	V
8	139	MFFZZ		80063	SC-D-972712-4A	WIRE ELEC 20 AWG MAKE FROM 81349 M5086/1-20-90	FT	V
8	140	MFFZZ		80063	SC-D-972712-3B	WIRE ELEC 18 AWG MAKE FROM 81349 M5086/1-18-1	FT	V

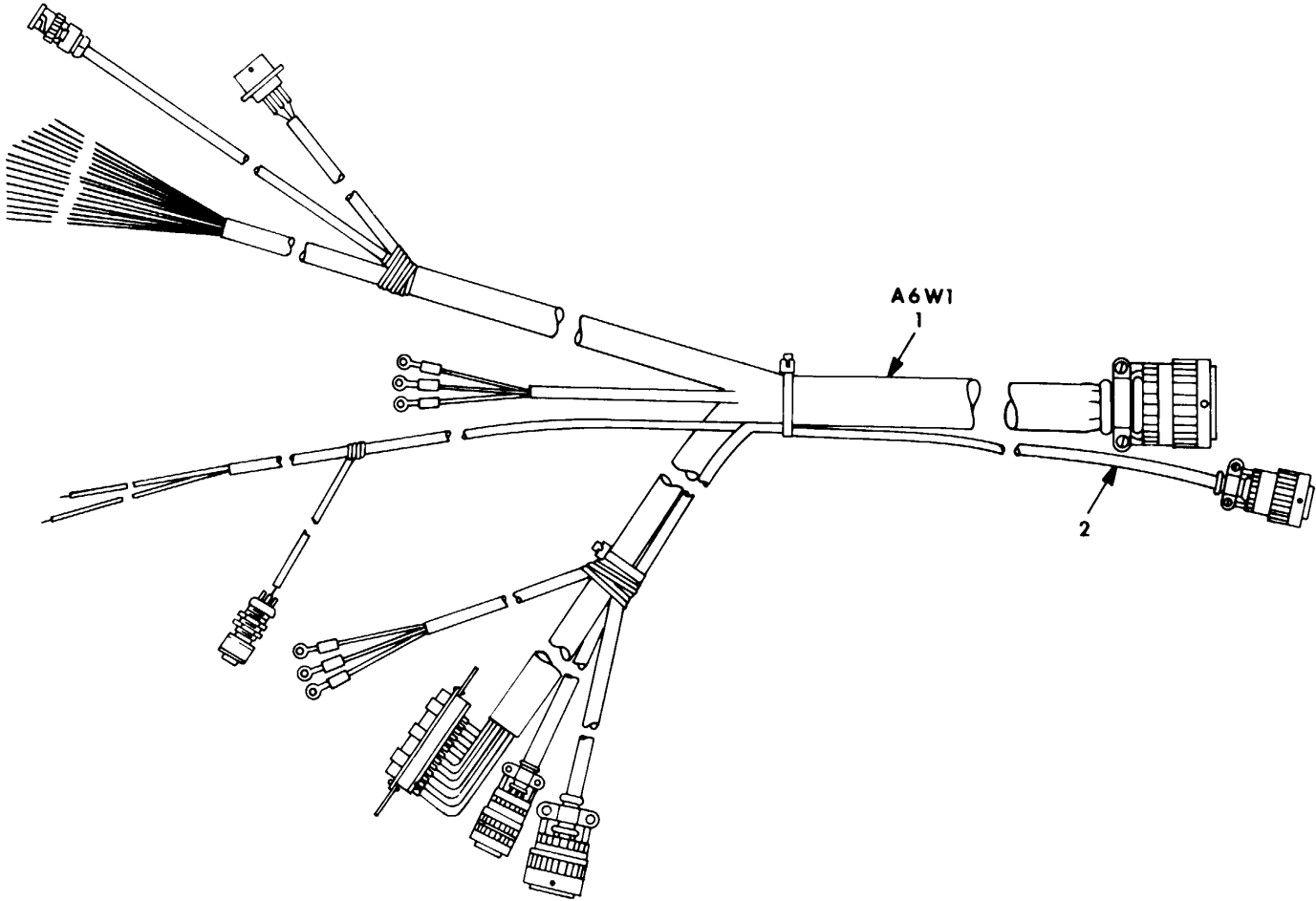

EL85A031

Figure 9. Control Cable Assembly (FM-3, ARC-131 and KY-28) (Sheet 1 of 6).

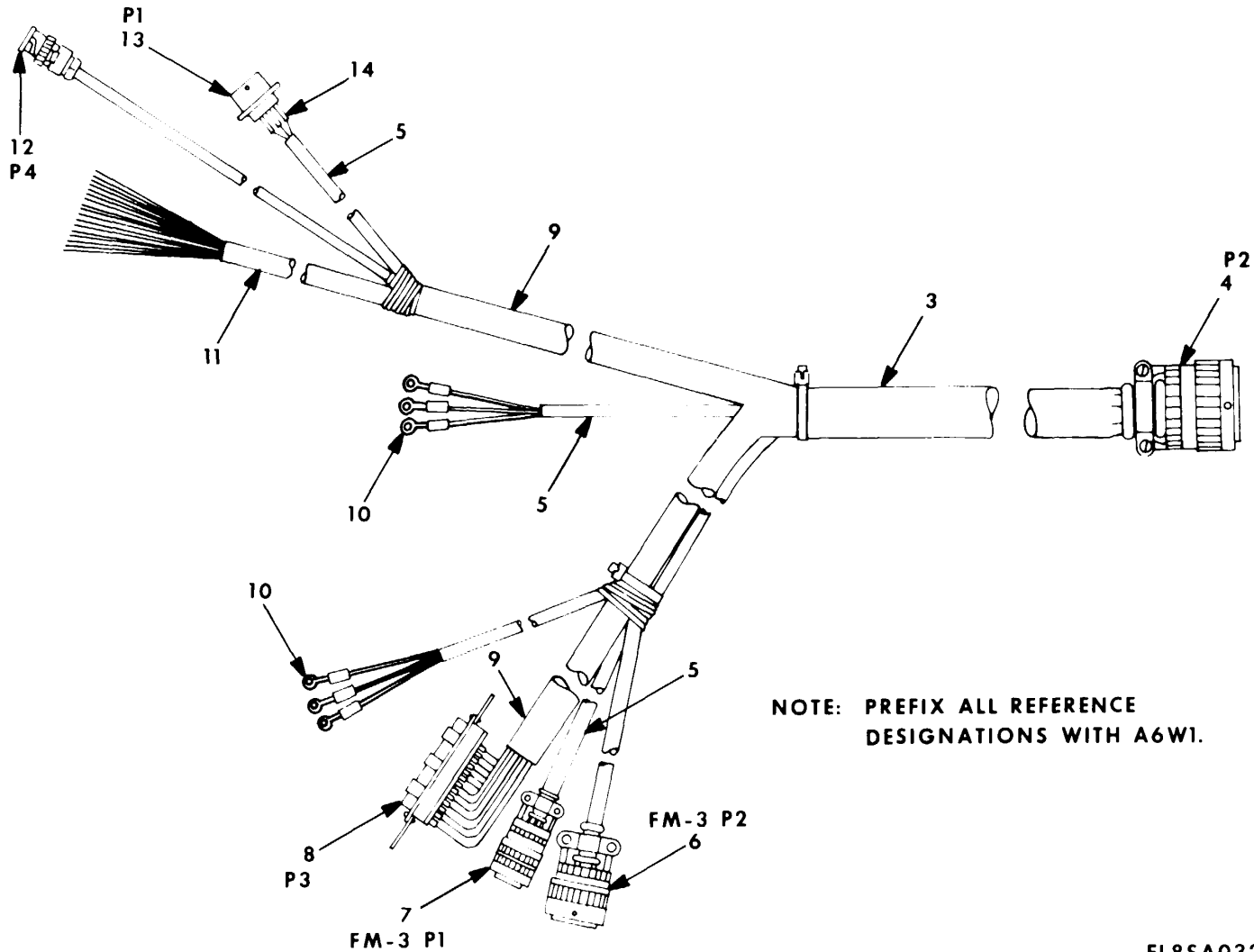

NOTE: PREFIX ALL REFERENCE DESIGNATIONS WITH A6W1.

EL8SA032

Figure 9. Control Cable Assembly (FM-3, ARC-131 and KY-28) (Sheet 2 of 6).

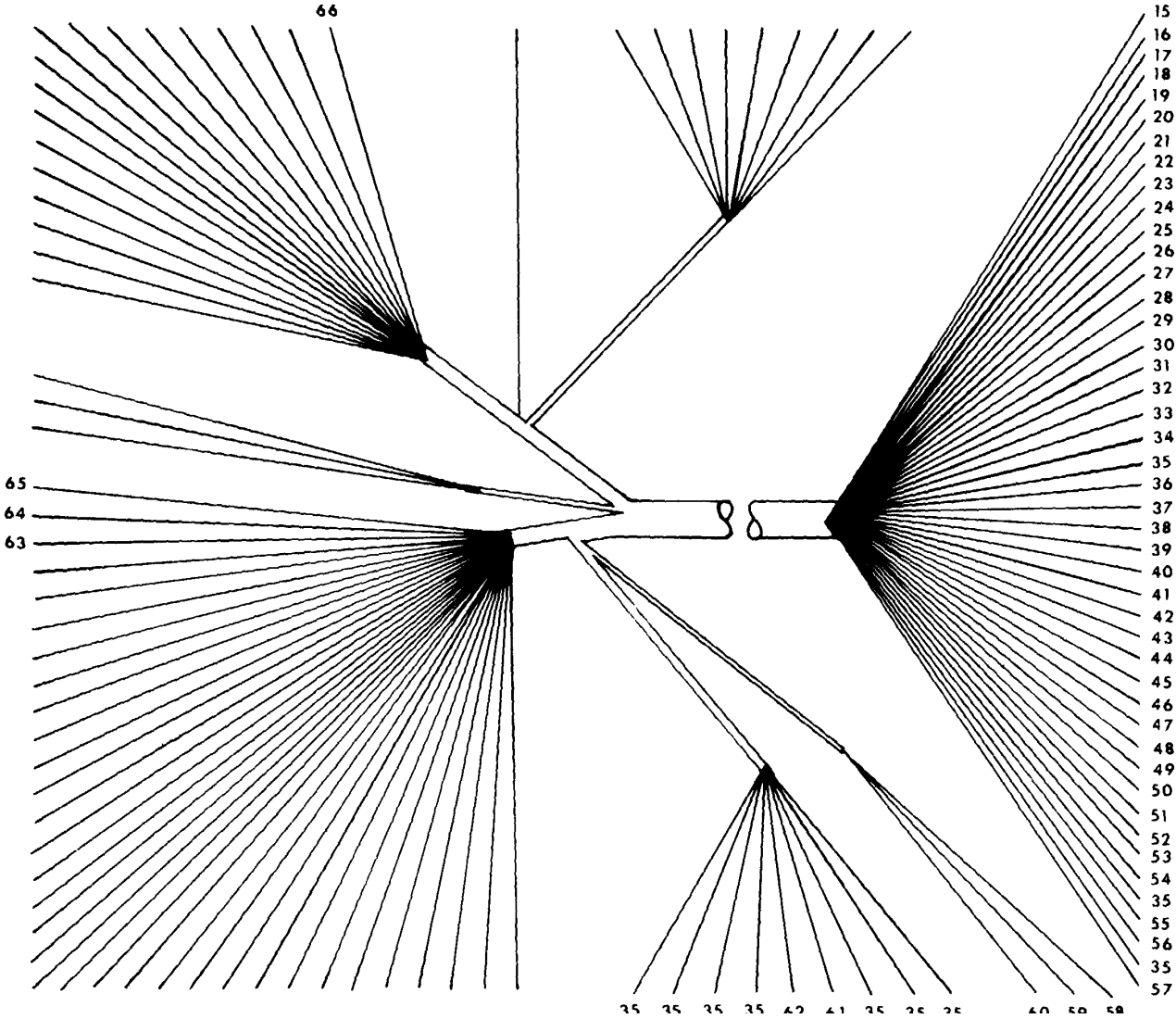

Figure 9. Control Cable Assembly (FM-3, ARC-131 and KY-28) (Sheet 3 of 6).

ITEM NO	FROM	TO	WIRE COLOR	AWG NO	WIRE LG INCHES
15	A6W1P2-AA	A6W1P1-A	W/BK/Y	20	61 3/8
16	A6W1P2-z	A6W1P1-B	W/BK/G	20	61 3/8
17	A6W1P2-j	A6W1P1-C	W/BK/BL	20	61 3/8
18	A6W1P2-L	A6W1P1-D	W/BK/V	20	61 3/8
19	A6W1P2-M	A6W1P1-E	W/BK/GY	20	61 3/8
20	A6W1P2-H	A6W1P1-F	W/BR/R	20	61 3/8
21	A6W1P2-g	A6W1P1-G	W/BR/O	20	61 3/8
22	A6W1P2-e	A6W1P1-J	W/BR/Y	20	61 3/8
23	A6W1P2-q	TB-9(15)	W/BR/BL	20	87
24	A6W1P2-D	TB-9(18)	W/BR/V	20	87 1/8
25	A6W1P2-C	TB-9(18)	W/BR/GY	20	87 1/4
26	A6W1P2-E	TB-9(19)	W/R/O	20	87 3/8
27	A6W1P2-a	TB-9(20)	W/R/Y	20	87 1/2
28	A6W1P2-y	TB-8(15)	W/R/G	20	87 5/8
29	A6W1P2-N	TB-8(16)	W/R/BL	20	87 3/4
30	A6W1P2-KK	TB-8(17)	W/R/V	20	87 7/8
31	A6W1P2-b	TB-8(18)	W/R/GY	20	88
32	A6W1P2-f	FILTER	W/Y/BL	20	39 7/8
33	A6W1P2-e	FILTER	W/Y/G	20	39 7/8
34	A6W1P2-F	FILTER	W/O/GY	20	39 7/8
35	A6W1P2-x	A6W1P3-6	SHIELDED	20	48 1/4
36	A6W1P2-S	A6W1P3-35	W/Y/V	20	48 3/8
37	A6W1P2-K	A6W1P3-4	W/Y/GY	20	48 1/2
38	A6W1P2-i	A6W1P3-37	W/G/BL	20	48 5/8
39	A6W1P2-d	A6W1P3-5	W/G/V	20	48 3/4
40	A6W1P2-T	A6W1P3-22	W/G/GY	20	48 7/8
41	A6W1P2-G	A6W1P3-23	W/BL/V	20	49
42	A6W1P2-CC	A6W1P3-24	W/BL/GY	20	49 1/8
43	A6W1P2-W	A6W1P3-8	W/V/GY	20	49 1/4
44	A6W1P2-v	A6W1P3-41	W/BK/BR/R	20	49 3/8
45	A6W1P2-BB	A6W1P3-25	W/BK/BR/O	20	49 1/2
46	A6W1P2-X	A6W1P3-9	W/BK/BR/Y	20	49 5/8
47	A6W1P2-k	A6W1P3-26	W/BK/BR/G	20	49 3/4
48	A6W1P2-Y	A6W1P3-10	W/BK/BR/BL	20	49 7/8
49	A6W1P2-U	A6W1P3-27	W/BK/BR/V	20	50
50	A6W1P2-Z	A6W1P3-11	W/BK/BR/GY	20	50 1/8
51	A6W1P2-P	A6W1P3-28	W/BK/R/O	20	50 1/4
52	A6W1P2-V	A6W1P3-12	W/BK/R/Y	20	50 3/8
53	A6W1P2-J	A6W1P3-29	W/BK/R/G	20	50 1/2
54	A6W1P2-LL	A6W1P3-30	W/BK/R/BL	20	50 5/8
35	A6W1P2-JJ	A6W1P3-13	SHIELDED	20	50 3/4
55	A6W1P2-m	A6W1P3-31	W/BK/R/V	20	50 7/8
56	A6W1P2-h	A6W1P3-32	W/BK/R/GY	20	51
35	A6W1P2-B	A6W1P3-14	SHIELDED	20	51 1/8
57	A6W1P2-R	A6W1P3-33	W/BK/O/Y	20	51 1/4
58	FILTER	A6W1P3-34	W/BK/O/G	20	20 1/8
59	FILTER	A6W1P3-18	W/BK/O/BL	20	20 1/4

EL8SA034

Figure 9. Control Cable Assembly (FM-3, ARC-131 and KY-28) (Sheet 4 of 6).

ITEM NO	FROM	TO	WIRE COLOR	AWG NO	WIRE LG INCHES
60	FILTER	A6W1P3-36	W/BK/O/V	20	20 3/8
35	FM-3 P2-W	A6W1P3-39	SHIELDED	20	35 1/8
35	FM-3 P2-P	A6W1P3-7	SHIELDED	20	35 1/4
35	FM-3 P2-D	A6W1P3-15	SHIELDED	20	35 3/8
61	FM-3 P2-M	TB-9(15)	W/O/Y	20	87 1/8
62	FM-3 P1-K	TB-8(17)	W/O/G	20	87 1/4
35	FM-3 P1-A	TB-10(15)	SHIELDED	20	87 5/8
35	FM-3 P2-V	TB-8(15)	SHIELDED	20	87 3/8
35	FM-3 P2-G	TB-8(16)	SHIELDED	20	87 7/8
35	FM-3 P1-F	TB-10(9)	SHIELDED	20	88
63	A6W1P3-44	TB-9(15)	W/O/BL	20	75 7/8
64	A6W1P3-3	TB-8(20)	W/O/V	20	76
65	RT ANT	A6W1P4	COAX CA	RG58	65 1/2
66	A6-8(11)	A6W1P1-H	W/BR/G	20	40 3/4

EL8SA035

Figure 9. Control Cable Assembly (FM-3, ARC-131 and KY-28) (Sheet 5 of 6).

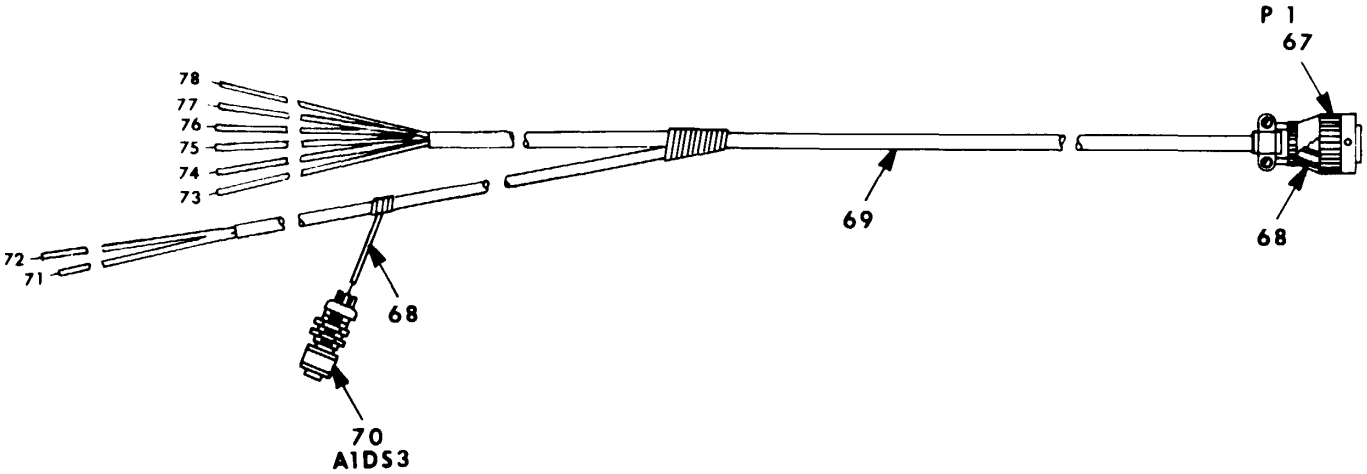

ITEM NO.	FROM	TO	WIRE COLOR	AWG NO.	WIRE LG. INCHES
68	C-8157 #3 P1-A	C-8157 #3 P1-H	WHT/GRN	20	12
68	FM-3 SCTY IND	C-8157 #3 P1-G	WHT/GRN	20	80 1/2
71	TB-8 (19)	C-8157 #3 P1-E	BLK	18	107
72	TB-10 (19)	C-8157 #3 P1-A	RED	18	107
73	FM-3 P2-Y	C-8157 #3 P1-K	WHT/YEL	20	63
74	FM-3 P2-Z	C-8157 #3 P1-J	WHT/ORG	20	63
75	FM-3 P2-H	C-8157 #3 P1-C	WHT/RED	20	63
76	FM-3 P2-R	C-8157 #3 P1-D	WHT/BRN	20	63
77	FM-3 P2-K	C-8157 #3 P1-F	WHT/BLK	20	63
78	FM-3 P2-J	C-8157 #3 P1-B	BRN	18	63

EL85A036

Figure 9. Control Cable Assembly (FM-3, ARC-131 and KY-28) (Sheet 6 of 6).

SECTION II

TM 11-5821-285-30P

(1) ILLUSTRATION		(2)	(3)	(4)	(5)	(6)	(7)	(8)
(a) FIG NO.	(b) ITEM NO.	SMR CODE	NATIONAL STOCK NUMBER	FSCM	PART NUMBER	DESCRIPTION USABLE ON CODE	U/M	QTY INC IN UNIT
						GROUP 08 CONTROL CABLE ASSEMBLY IFM-3, ARC-131 AND KY-28)		
9	1	AFFFF		80063	SC-D-972716	CABLE ASSEMBLY.....	EA	1
9	2	AFFFF		80063	SC-D-972718	CABLE ASSEMBLY.....	EA	1
9	3	MFFZZ		80063	SC-D-972716-4	INSULATION SLEEVE MAKE FROM 5970-00-892-0986	FT	V
9	4	PAFZZ	5935-00-892-9894	96906	MS3116E24-61S	CONNECTOR,PLUG,ELEC.....	EA	1
9	5	MFFZZ		80063	SC-D-972716-5	INSULATION SLEEVE MAKE FROM 5970-01-094-0479	FT	V
9	6	PAFZZ		96906	MS3476F-16-26S	CONNECTOR,PLUG,ELEC.....	EA	1
9	7	PAFZZ		96906	MS3476F-12-10S	CONNECTOR,PLUG,ELEC.....	EA	1
9	8	PAFZZ	5935-00-089-8052	80063	SM-B-620336	CONNECTOR KIT ASSEM.....	EA	1
9	9	MFFZZ		80063	SC-D-972716-2	INSULATION SLEEVE MAKE FROM 5970-00-892-1020	FT	V
9	10	PAFZZ	5940-00-113-3138	96906	MS20659-102	TERMINAL,LUG.....	EA	6
9	11	MFFZZ		80063	SC-D-972716-3	INSULATION SLEEVE MAKE FROM 5970-00-681-9774	FT	V
9	12	PAFZZ	5935-01-043-0629	81349	M39012/16-0101	CONNECTOR,PLUG,ELEC.....	EA	1
9	13	PAFZZ	5935-00-826-1020	96906	MS3112E12-10S	CONNECTOR,RECEPTACL.....	EA	1
9	14	MFFZZ		81349	M23053/2-105-0	INSULATION SLEEVING MAKE FROM 81349 M23053/2-105-0.....	FT	V
9	15	MFFZZ		80063	SC-D-972716-1S	WIRE ELEC 20 AWG MAKE FROM 81349 MWC20-7J904	FT	V
9	16	MFFZZ		80063	SC-D-972716-1T	WIRE ELEC 20 AWG MAKE FROM 81349 MWC20-7J905	FT	V
9	17	MFFZZ		80063	SC-D-972716-1U	WIRE ELEC 20 AWG MAKE FROM 81349 MCW20-7J906	FT	V
9	18	MFFZZ		80063	SC-D-972716-1V	WIRE ELEC 20 AWG MAKE FROM 81349 MWC20-7J907	FT	V
9	19	MFFZZ		80063	SC-D-972716-1W	WIRE ELEC 20 AWG MAKE FROM 81349 MWC20-7J908	FT	V
9	20	MFFZZ		80063	SC-D-972716-1X	WIRE ELEC 20 AWG MAKE FROM 81349 MWC20-7J912	RL	V
9	21	MFFZZ		80063	SC-D-972716-1Y	WIRE ELEC 20 AWG MAKE FROM 81349 MWC20-7J913	FT	V
9	22	MFFZZ		80063	SC-D-972716-1Z	WIRE ELEC 20 AWG MAKE FROM 81349 MWC20-7J914	FT	V
9	23	MFFZZ		80063	SC-D-972716-1ZB	WIRE ELEC 20 AWG MAKE FROM 91349 MWC20-7J916 EZ3	FT	V
9	24	MFFZZ		80063	SC-D-972716-1ZC	WIRE ELEC 20 AWG MAKE FROM 81349 MWC20-7J917	FT	V
9	25	MFFZZ		80063	SC-D-972716-1ZD	WIRE ELEC 20 AWG MAKE FROM 81349 MWC20-7J918	FT	V
9	26	NFFZZ		80063	SC-D-972716-1ZE	WIRE ELEC 20 AWG MAKE FROM 81349 MWC20-7J923	FT	V
9	27	MFFZZ		80063	SC-D-972716-1ZF	WIRE ELEC 20 AWG MAKE FROM 81349 MWC20-7J924	FT	V
9	28	MFFZZ		80063	SC-D-972716-1ZG	WIRE ELEC 20 AWG MAKE FROM 81349 MWCZO-7J925	FT	V
9	29	MFFZZ		80063	SC-D-972116-1ZH	WIRE ELEC 20 AWG MAKE FROM 81349 MWC20-7J926	FT	V
9	30	MFFZZ		80063	SC-D-9T2116-1ZJ	WIRE ELEC 20 AWG MAKE FROM 81349 MWC20-7J927	FT	V
9	31	MFFZZ		80063	SC-D-972116-1ZK	WIRE ELEC 20 AWG MAKE FROM 81349 MWC20-7J928	FT	V
9	32	MFFZZ		80063	SC-D-9727T16-1ZS	WIRE ELEC 20 AWG MAKE FROM 81349 MWC20-7J946	FT	V
9	33	MFFZZ		80063	SC-D-972T716-1ZR	WIRE ELEC 20 AWG MAKE FROM 81349 MWC20-7J945	FT	V
9	34	MFFZZ		80063	SC-D-972716-1ZQ	WIRE ELEC 20 AWG MAKE FROM 81349 MWC20-7J938	FT	V
9	35	MFFZZ		81349	MWC20-7JS9	CARLE,SPECIAL PURPO MAKE FROM 81349 MWC20-7JS9.....	FT	V
9	36	MFFZZ		80063	SC-D-972716-1ZT	WIRE ELEC 20 AWG MAKE FROM 81349 MWC20-7J947	FT	V
9	37	MFFZZ		80063	SC-D-972716-1ZU	WIRE ELEC 20 AWG MAKE FROM 81349 NWC20-7J948	FT	V
9	38	MFFZZ		80063	SC-D-972716-1ZV	WIRE ELEC 20 AWG MAKE FROM 81349 MWC20-7J956	FT	V

SECTION II

TM 11-5821-285-30P

(1) ILLUSTRATION		(2)	(3)	(4)	(5)	(6)	(7)	(8)
(a) FIG NO.	(b) ITEM NO.	SMR CODE	NATIONAL STOCK NUMBER	FSCM	PART NUMBER	DESCRIPTION USABLE ON CODE	U/M	QTY INC IN UNIT
9	39	MFFZZ	6210-00-538-8770	80063	SC-D-972716-1Z	WIRE ELEC 20 AWG MAKE FROM 81349 MWC20-7J957	FT	V
9	40	MFFZZ		80063	SC-D-972716-1ZW	WIRE ELEC 20 AWG MAKE FROM 81349 MWC20-7J958	FT	V
9	41	MFFZZ		80063	SC-D-972716-1ZX	WIRE ELEC 20 AWG MAKE FROM 81349 MWC20-7J961	FT	V
9	42	MFFZZ		80063	SC-D-972716-1ZY	WIRE ELEC 20 AWG MAKE FROM 81349 MWC20-7J968	FT	V
9	43	MFFZZ		80063	SC-D-972716-1ZZ	WIRE ELEC 20 AWG MAKE FROM 81349 MWC20-7J978	FT	V
9	44	MFFZZ		80063	SC-D-972716-1A	WIRE ELEC 20 AWG MAKE FROM 81349 MWC20-7J9012		FTV
9	45	MFFZZ		80063	SC-D-972716-1B	WIRE ELEC 20 AWG MAKE FROM 81349 MWC20-7J9013		FTV
9	46	MFFZZ		80063	SC-D-972716-1C	WIRE ELEC 20 AWG MAKE FROM 81349 MWC20-7J9014		FTV
9	47	MFFZZ		80063	SC-D-972716-1D	WIPE ELEC 20 AWG MAKE FROM 81349 MWC20-7J9015		FTV
9	48	MFFZZ		80063	SC-D-972716-1E	WIRE ELEC 20 AWG MAKE FROM 81349 MWC20-7J9016		FTV
9	49	MFFZZ		80063	SC-D-972716-1F	WIRE ELEC 20 AWG MAKE FROM 81349 MWC20-7J9017		FTV
9	50	MFFZZ		80063	SC-D-972716-1G	WIRE ELEC 20 AWG MAKE FROM 81349 MWC20-7J9018		FTV
9	51	MFFZZ		80063	SC-D-972716-1H	WIRE ELEC 20 AWG MAKE FROM 81349 MWC20-7J9023		FTV
9	52	MFFZZ		80063	SC-D-972716-1J	WIRE ELEC 20 AWG MAKE FROM 81349 MWC20-7J9024		FTV
9	53	MFFZZ		80063	SC-D-972716-1K	WIRE ELEC 20 AWG MAKE FROM 81349 MWC20-7J9025		FTV
9	54	MFFZZ		80063	SC-D-972716-1L	WIRE ELEC 20 AWG MAKE FROM 81349 MWC20-7J9026		FTV
9	55	MFFZZ		80063	SC-D-972716-1M	WIRE ELEC 20 AWG MAKE FROM 81349 MWC20-7J9027		FTV
9	56	MFFZZ		80063	SC-D-972716-1N	WIRE ELEC 20 AWG MAKE FROM 81349 MWC20-7J9028		FTV
9	57	MFFZZ		80063	SC-D-972716-1P	WIRE ELEC 20 AWG MAKE FROM 81349 MWC20-7J9034		FTV
9	58	MFFZZ		80063	SC-D-972716-2B	WIRE ELEC 20 AWG MAKE FROM 81349 MWC20-7J9035		FTV
9	59	MFFZZ		80063	SC-D-972716-1Q	WIRE ELEC 20 AWG MAKE FROM 81349 MWC20-7J9036		FTV
9	60	MFFZZ		80063	SC-D-972716-1R	WIRE ELEC 20 AWG MAKE FROM 81349 MWC20-7J9037		FTV
9	61	MFFZZ		80063	SC-D-972716-1ZL	WIRE ELEC 20 AWG MAKE FROM 81349 MWC20-7J934	FT	V
9	62	MFFZZ		80063	SC-D-972716-1ZM	WIRE ELEC 20 AWG MAKE FROM 81349 MWC20-7J935	FT	V
9	63	MFFZZ		80063	SC-D-972716-1ZN	WIRE ELEC 20 AWG MAKE FROM 81349 MWC20-TJ936	FT	V
9	64	MFFZZ		80063	SC-D-972716-1ZP	WIRE ELEC 20 AWG MAKE FROM 81349 MWCZO-7J937	FT	V
9	65	MFFZZ		69006	SC-D-972716-1	CABLE RF MAKE FROM 81349 RG58U	FT	V
9	66	MFFZZ		81349	MWC20-7J9	WIRE ELECTRICAL MAKE FROM 81349 MWC20-7J915	FT	V
9	67	PAFZZ		96906	MS3476F12-10S	CONNECTOR,PLUG,ELEC	EA	1
9	68	MFFZZ		80063	SC-D-972718-3F	WIRE ELEC 20 AWG MAKE FROM 81349 M5086/1-20-95	FT	V
9	69	MFFZZ		80063	SC-D-972718-4	INSULATION SLEEVING MAKE FROM 5970-00-942-7612	FT	V
9	70	PAFZZ		96906	MS25041-3	LIGHT,INDICATOR.....	EA	1
9	71	MFFZZ		80063	SC-D-972718-2A	WIRE ELEC 18 AWG MAKE FROM 81349 M5086/1-18-0	FT	V
9	72	MFFZZ		80063	SC-D-972718-2C	WIRE ELEC 18 AWG MAKE FROM 81349 M5086/1-18-2	FT	V
9	73	MFFZZ		80063	SC-D-972718-3E	WIRE ELEC 20 AWG MAKE FROM 81349 M5086/1-20-94	FT	V
9	74	MFFZZ		80063	SC-D-972718-3D	WIRE ELEC 20 AWG MAKE FROM 81349 M5086/1-20-93	FT	V
9	75	MFFZZ		80063	SC-D-972718-3C	WIRE ELEC 20 AWG MAKE FROM 81349 M5086/1-20-92	FT	V
9	76	MFFZZ		80063	SC-D-972718-3B	WIRE ELEC 20 AWG MAKE FROM 81349 M5086/1-20-91	FT	V
9	77	MFFZZ		80063	SC-D-972718-3A	WIRE ELEC 20 AWG MAKE FROM 81349 M5086/1-20-90	FT	V

SECTION II

TM 11-5821-285-30P

(1) ILLUSTRATION		(2)	(3)	(4)	(5)	(6)	(7)	(8)
(a) FIG NO.	(b) ITEM NO.	SMR CODE	NATIONAL STOCK NUMBER	FSCM	PART NUMBER	DESCRIPTION USABLE ON CODE	U/M	QTY INC IN UNIT
9	78	MFFZZ		80063	SC-D-972718-2B	WIRE ELEC 18AWG MAKE FROM 81349 M5086/1-18-1 57/(58 blank)	FT	V

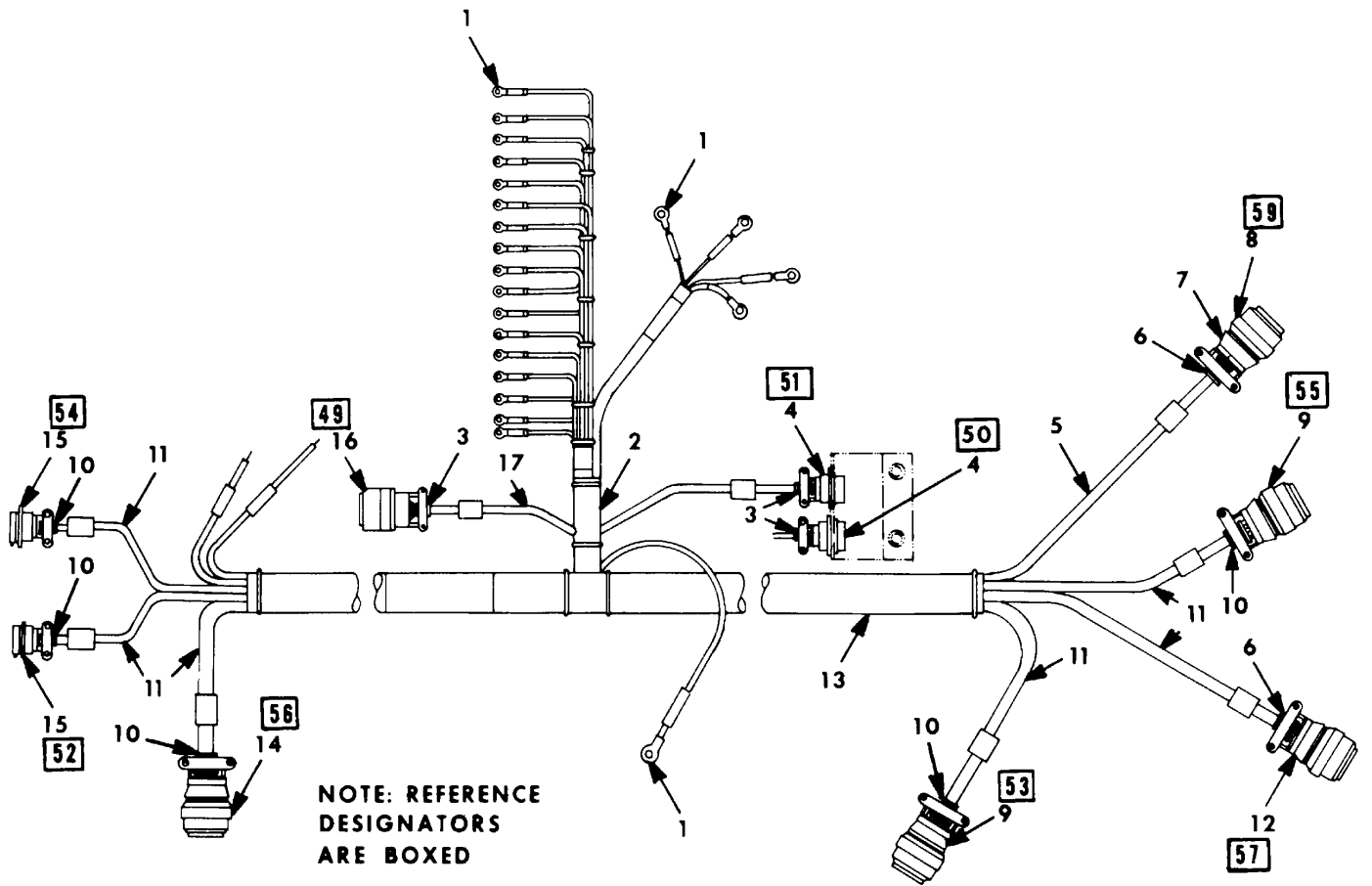

EL85AO37

Figure 10. Secure Retransmission Wire Harness Assembly (Sheet 1 of 4).

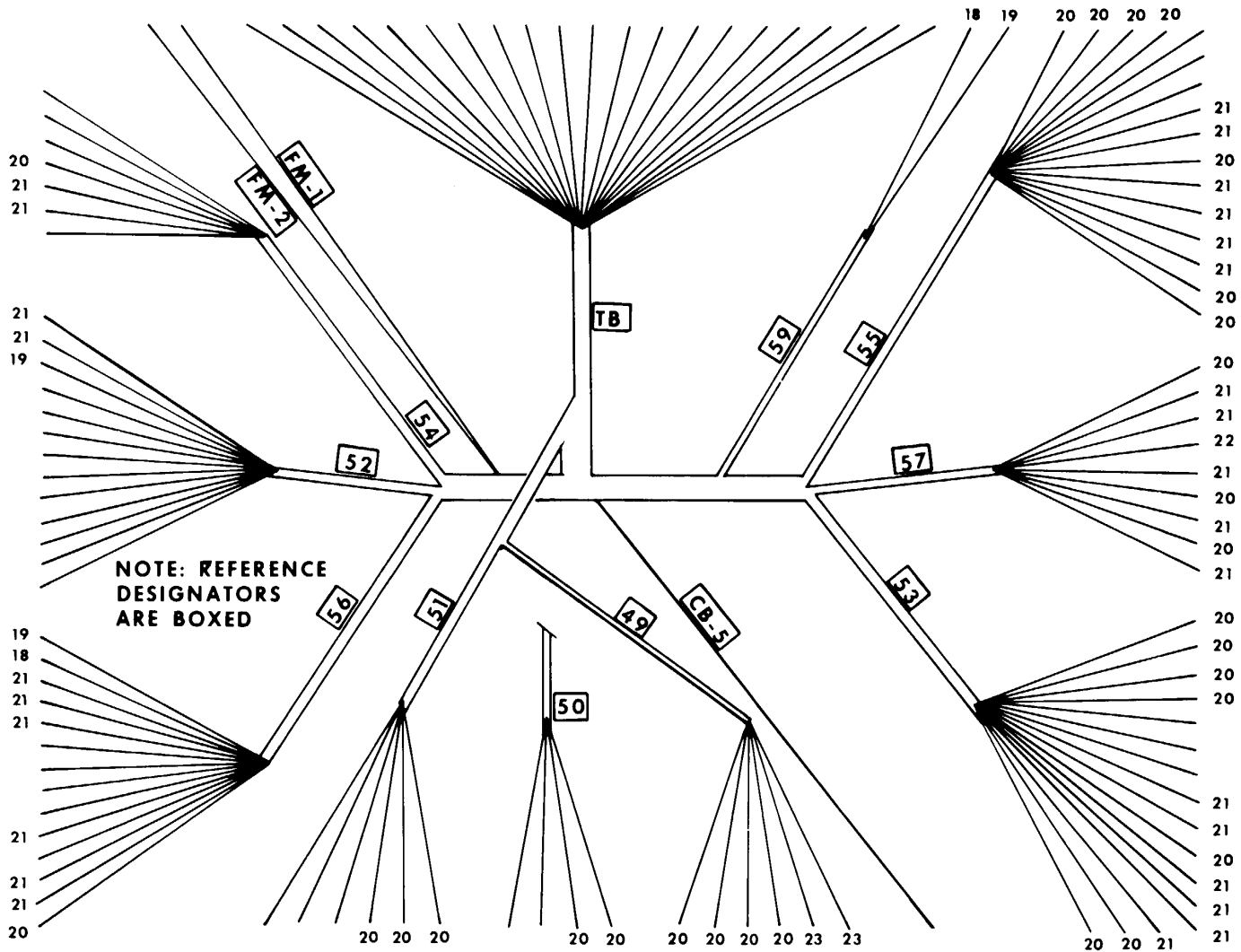

EL85A038

Figure 10. Secure Retransmission Wire Harness Assembly (Sheet 2 of 4).

ITEM NO	FROM	TO	WIRE COLOR	AWG NO	WIRE LG INCHES
18	59-A	CB-5	RED	18	61
19	59-B	TB-11(1)	BLK	18	62 ½
20	55-c	55-V	WHT	20	7
20	55-S	55-T	WHT	20	7
20	55-X	55-Y	WHT	20	7
20	55-A	54-S	WHT	20	64
21	55-R	54-P	SHD	20	64
21	55-D	54-V	SHD	20	64
20	55-M	54-W	WHT	20	64
21	55-P	54-D	SHD	20	64
21	55-B	TB-1(4)	SHD	20	54
21	55-F	TB-11(3)	SHD	20	54 ½
21	55-J	SHIELD GRD	SHD	20	4
20	55-K	51-B	WHT	20	62
20	55-C	TB-12(3)	WHT	20	64
20	57-A	56-S	WHT	20	71
21	57-R	56-P	SHD	20	71
21	57-D	56-V	SHD	20	71
22	57-L	56-c	WHT	18	71
21	57-P	56-D	SHD	20	71
20	57-C	TB-11(2)	WHT	20	58
21	57-B	56-G	SHD	20	71
20	57-H	56-X	WHT	20	71
21	57-J	SHIELD GRD	SHD	20	4
20	53-c	53-V	WHT	20	7
20	53-S	53-T	WHT	20	7
20	53-X	53-Y	WHT	20	7
20	53-A	52-S	WHT	20	58
21	53-R	52-P	SHD	20	58
21	53-D	52-V	SHD	20	58
20	53-M	52-W	WHT	20	58
21	53-P	52-D	SHD	20	58
21	53-B	TB-11(6)	SHD	20	51
21	53-F	TB-11(5)	SHD	20	51 ½
21	53-J	SHIELD GRD	SHD	20	4
20	53-C	51-C	WHT	20	60
20	53-K	51-A	WHT	20	60
23	49-A	FM-1 P3-10	BLK	20	52
23	49-B	FM-2 P3-10	BLK	20	56
20	49-C	TB-8(1)	WHT	20	35
20	49-D	TB-8(3)	WHT	20	35
20	49-E	TB-9(1)	WHT	20	35
20	49-F	TB-9(3)	WHT	20	35
20	50-C	50-D	WHT	20	7
20	50-E	50-F	WHT	20	7
20	51-D	TB-12(5)	WHT	20	30 ½
20	51-E	TB-12(3)	WHT	20	30

EL8SA039

Figure 10. Secure Retransmission Wire Harness Assembly (Sheet 3 of 4).

ITEM NO	FROM	TO	WIRE COLOR	AWG NO	WIRE LG INCHES
20	51-F	TB-12(2)	WHT	20	29 ½
20	56-M	TB-11(2)	WHT	20	39
21	56-E	SHIELD GRD	SHD	20	4
21	56-R	52-R	SHD	20	24
21	56-b	56-R	SHD	20	7
21	56-H	52-H	SHD	20	24
21	56-Z	52-Z	SHD	20	24
21	56-Y	52-Y	SHD	20	24
18	56-J	52-J	RED	18	24
19	56-K	TB-11(1)	BLK	18	39 ½
19	52-K	TB-11(1)	BLK	18	31 ½
21	52-G	TB-11(6)	SHD	20	29
21	52-L	SHIELD GRD	SHD	20	4
21	54-G	TB-11(4)	SHD	20	34
21	54-L	SHIELD GRD	SHD	20	4
20	TB-11(2)	TB-12(6)	WHT	20	13

EL8SA040

Figure 10. Secure Retransmission Wire Harness Assembly (Sheet 4 of 4).

SECTION II

TM 11-5821-285-30P

(1) ILLUSTRATION		(2)	(3)	(4)	(5)	(6)	(7)	(8)
(a) FIG NO.	(b) ITEM NO.	SMR CODE	NATIONAL STOCK NUMBER	FSCM	PART NUMBER	DESCRIPTION USABLE ON CODE	U/M	QTY INC IN UNIT
						GROUP 09 SECURE RETRANSMISSION WIRE HARNES ASSEMBLY		
10	1	PAFZZ		96906	MS2536-103	TERMINAL LUG.....	EA	22
10	2	MFFZZ		80063	SC-D-972711-2	INSULATION SLEEVE MAKE FROM 81349 MIL-I-631		FTV
10	3	PAFZZ	5365-00-682-1427	96906	MS3420-4A	BUSHING, RUBBER.....	EA	3
10	4	PAFZZ	5935-00-936-8561	96906	MS3124F01-6S	CONNECTOR, RECEPTAC.....	EA	2
10	5	MFFZZ		80063	SC-D-972711-3	INSULATION SLEEVING MAKE FROM 5970-00-812-2969	FT	V
10	6	PAFZZ	5365-00-828-8526	96906	MS3420-6A	BUSHING, RUBBER.....	EA	2
10	7	PAFZZ	5365-00-598-5394	96906	MS3420-8A	BUSHING, RUBBER.....	EA	1
10	8	PAFZZ	5935-00-761-3885	96906	MS3126F14-5S	CONNECTOR, PLUG, ELEC.....	EA	1
10	9	PAFZZ	5935-00-725-7723	96906	MS53126F16-26P	CONNECTOR, PLUG, ELEC.....	EA	2
10	10	PAFZZ	5365-00-721-7554	96906	MS3420-10A	BUSHING, RUBBER.....	EA	5
10	11	MFFZZ		80063	SC-D-972711-2A	INSULATION SLEEVING MAKE FROM 5970-00-954-1624	FT	V
10	12	PAFZZ		96906	MS3126F12-14P	CONNECTOR, PLUG, ELEC.....	EA	1
10	13	MFFZZ		81349	MIL-I-631	INSULATION SLEEVE MAKE FROM 81349 MIL-I-631		FTV
10	14	PAFZZ	5935-00-904-5873	80063	SC-D-972711-1	CONNECTOR, PLUG, ELEC.....	EA	1
10	15	PAFZZ		96906	MS3126F16-26PU	CONNECTOR PLUG.....	EA	2
10	16	PAFZZ	5935-00-726-6519	96906	MS3126F10-6P	CONNECTOR, PLUG, ELEC.....	EA	1
10	17	MFFZZ		80063	SC-D-972711-4	INSULATION SLEEVING MAKE FROM 5970-00-954-1622	FT	V
10	18	MFFZZ		80063	SC-D-972711-21	WIRE ELEC 18 AWG MAKE FROM 81349 MWC18-7J2	FT	V
10	19	MFFZZ		80063	SC-D-972711-20	WIRE ELEC 18 AWG MAKE FROM 81349 MWC18-7J0	FT	V
10	20	MFFZZ		80063	SC-D-972711-23	WIRE ELECTRICAL MAKE FROM 81349 MWC20-7J9		FTV
10	21	MFFZZ		80063	SC-D-972711-1Z	CABLE, SPECIAL PURPO MAKE FROM 81349 MWC20-7JSJ9.....	FT	V
10	22	MFFZZ		80063	SC-D-972711-25	WIRE ELEC 18 AWG MAKE FROM 81349 MWC18-7J9	FT	V
10	23	MFFZZ		80063	SC-D-972711-24	WIRE, ELECTRICAL MAKE FROM 81349 MWC22-7J0	FT	V

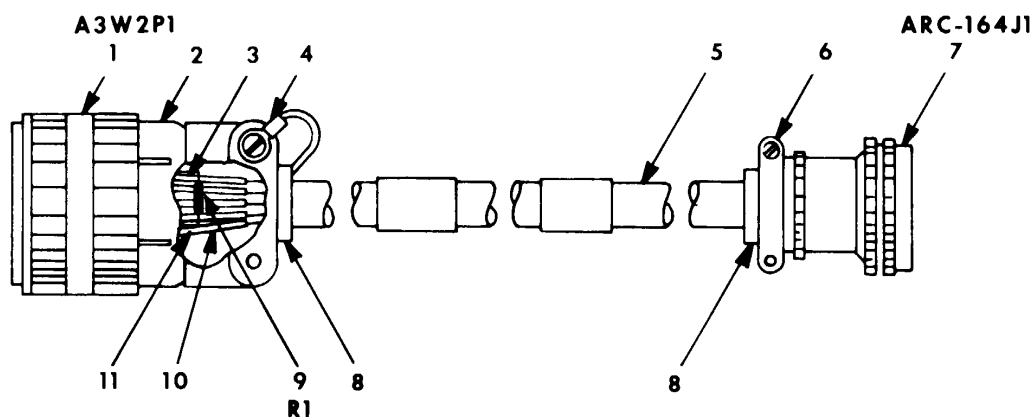

ITEM NO.	FROM	TO	WIRE COLOR	AWG NO.	WIRE LG. INCHES
3	A3W2P1-Q	ARC-164 J1-D	WHT	20	52
3	A3W2P1-G	ARC-164 J1-E	WHT	20	52
11	A3W2P1-R	ARC-164 J1-d	SHD	20	52
3	A3W2P1-K	ARC-164 J1-h	WHT	20	52
11	A3W2P1-L	ARC-164 J1-K	SHD	20	52
3	A3W2P1-F	A3W2P1-SHD	WHT	20	52
3	A3W2P1-D	ARC-164 J1-a	WHT	20	52
11	A3W2P1-C	ARC-164 J1-L	SHD	20	52
3	A3W2P1-P	ARC-164 J1-C	WHT	20	52
3	A3W2P1-G	BACKSHELL	WHT	20	6
3	ARC-164 J1-P	ARC-164 J1-E	WHT	20	6
11	ARC-164 J1-e	ARC-164 J1-L (SHD)	SHD	20	6
3	ARC-164 J1-V	ARC-164 J1-B	WHT	20	6

EL8SA041

Figure 11. Cable Assembly Control.

SECTION II

TM 11-5821-285-30P

(1) ILLUSTRATION		(2)	(3)	(4)	(5)	(6) DESCRIPTION	(7)	(8)
(a) FIG NO.	(b) ITEM NO.	SMR CODE	NATIONAL STOCK NUMBER	FSCM	PART NUMBER	USABLE ON CODE	U/M	QTY INC IN UNIT
						GROUP 10 CABLE ASSEMBLY, CONTROL		
11	1	PAFZZ	5935-00-752-2979	96906	MS3106B28-16P	CONNECTOR, PLUG, ELEC.....	EA	1
11	2	PAFZZ	5935-00-280-2353	96906	MS3057-A	ADAPTER, CABLE CLAMP	EA	1
11	3	MFFZZ		80063	SC-D-972713-5	WIRE, ELECTRICAL MAKE FROM 81349 MWC20-7J9	FT	V
11	4	PAFZZ	5940-00-143-4771	96906	MS25036-103	TERMINAL, LUG	EA	1
11	5	MFFZZ		80063	SC-D-972713-2	INSULATION SLEEVING MAKE FROM 5970-00-954-1624	FT	V
11	6	PAFZZ	5935-00-173-5048	96906	MS27506B18-2	ADAPTER, CABLE CLAMP	EA	1
11	7	PAFZZ	5935-00-163-3644	96906	MS27473T18B 32S	CONNECTOR, PLUG, ELEC.....	EA	1
11	8	PAFZZ	5365-01-108-2256	88044	MS3420-1	BUSHING	EA	2
11	9	PAFZZ	5905-00-108-6922	81349	RCR20G151JS	RESISTOR, FIXED, COMP	EA	1
11	10	MFFZZ		80063	SC-D-972713-6	INSULATION SLEEVING MAKE FROM 5970-00-819-9569	FT	V
11	11	MFFZZ		80063	SC-D-972713-12	WIRE ELEC SHIELDED MAKE FROM 81349 MWC20-7JS9	FT	V
65/(66 blank)								

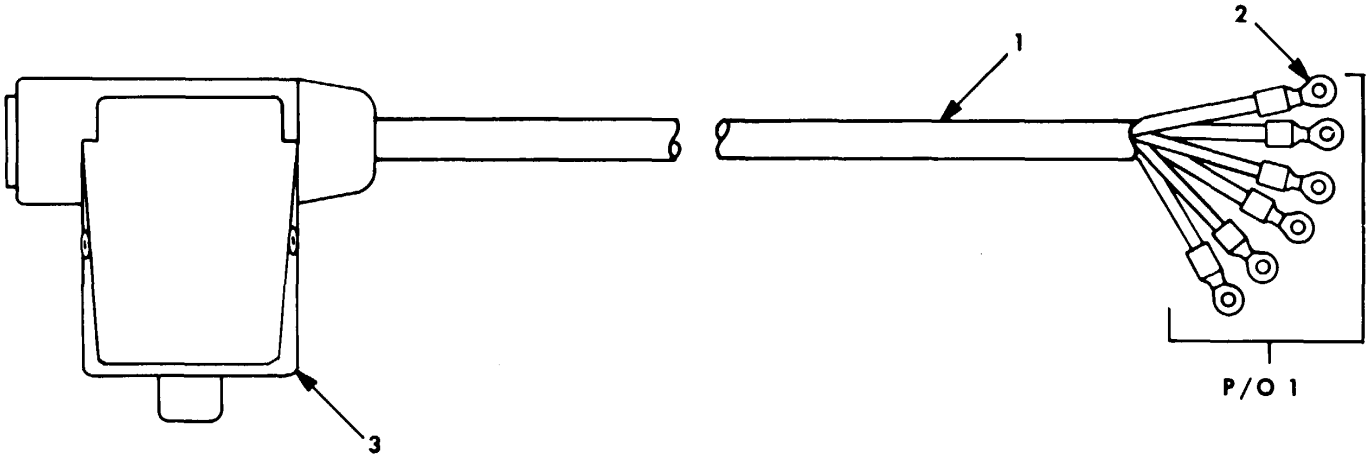

EL8SA042

Figure 12. Cable Assembly (Station 1-6) (Sheet 1 of 2).

ITEM NO	FROM	TO	WIRE COLOR	AWG NO	WIRE LG INCHES
1	TB-1(29)	STA-1 U-94/U-P3	RED	20	64
1	TB-1(28)	STA-1 U-94/U-P1	GRN	20	64
1	TB-1(27)	STA-1 U-94/U	SHD	20	64
1	TB-1(26)	STA-1 U-94/U-P2	WHT	20	64
1	TB-1(25)	STA-1 U-94/U-P4	BLK	20	64
1	TB-1(24)	STA-1 P/T SW	YEL	20	64
1	TB-2(29)	STA-2 U-94/U-P3	RED	20	64
1	TB-2(28)	STA-2 U-94/U-P1	GRN	20	64
1	TB-2(27)	STA-2 U-94/U	SHD	20	64
1	TB-2(26)	STA-2 U-94/U-P2	WHT	20	64
1	TB-2(25)	STA-2 U-94/U-P4	BLK	20	64
1	TB-2(24)	STA-2 P/T SW	YEL	20	64
1	TB-3(29)	STA-3 U-94/U-P3	RED	20	64
1	TB-3(28)	STA-3 U-94/U-P1	RRN	20	64
1	TB-3(27)	STA-3 U-94/U	SHD	20	64
1	TB-3(26)	STA-3 U-94/U-P2	WHT	20	64
1	TB-3(25)	STA-3 U-94/U-P4	BLK	20	64
1	TB-3(24)	STA-3 P/T SW	YEL	20	64
1	TB-4(29)	STA-4 U-94/U-P3	RED	20	64
1	TB-4(28)	STA-4 U-94/U-P1	RRN	20	64
1	TB-4(27)	STA-4 U-94/U	SHD	20	64
1	TB-4(26)	STA-4 U-94/U-P2	WHT	20	64
1	TB-4(25)	STA-4 U-94/U-P4	BLK	20	64
1	TB-4(24)	STA-4 P/T SW	YEL	20	64
1	TB-5(29)	STA-5 U-94/U-P3	RED	20	95
1	TB-5(28)	STA-5 U-94/U-P1	GRN	20	95
1	TB-5(27)	STA-5 U-94/U	SHD	20	95
1	TB-5(26)	STA-5 U-94/U-P2	WHT	20	95
1	TB-5(25)	STA-5 U-94/U-P4	BLK	20	95
1	TB-5(24)	STA-5 P/T SW	YEL	20	95
1	TB-6(29)	STA-6 U-94/U-P3	RED	20	103
1	TB-6(28)	STA-6 U-94/U-PI	GRN	20	103
1	TB-6(27)	STA-6 U-94/U	SHD	20	103
1	TB-6(26)	STA-6 U-94/U-P2	WHT	20	103
1	TB-6(25)	STA-6 U-94/U-P4	BLK	20	103
1	TB-6(24)	STA-6 P/T SW	YEL	20	103

EL8SA043

Figure 12D. Cable Assembly (Station 1-6) (Sheet 2 of 2).

SECTION II

TM 11-5821-285-30P

(1) ILLUSTRATION		(2)	(3)	(4)	(5)	(6)	(7)	(8)
(a) FIG NO.	(b) ITEM NO.	SMR CODE	NATIONAL STOCK NUMBER	FSCM	PART NUMBER	DESCRIPTION USABLE ON CODE	U/M	QTY INC IN UNIT
12	1	MFFZZ		80063	SC-D-972801-2-1	GROUP 11 CABLE ASSEMBLY (STATION 1-6)		
12	2	PAFZZ	5940-00-204-8966	96906	MS25036-102	CABLE, SPECIAL PURPO MAKE FROM 6145-00-635-1536	EA	28
12	3	PAFZZ	5935-00-553-9352	80058	U94A/U	TERMINAL, LUG CONNECTOR, PLUG, ELEC.....	EA	1
					69			

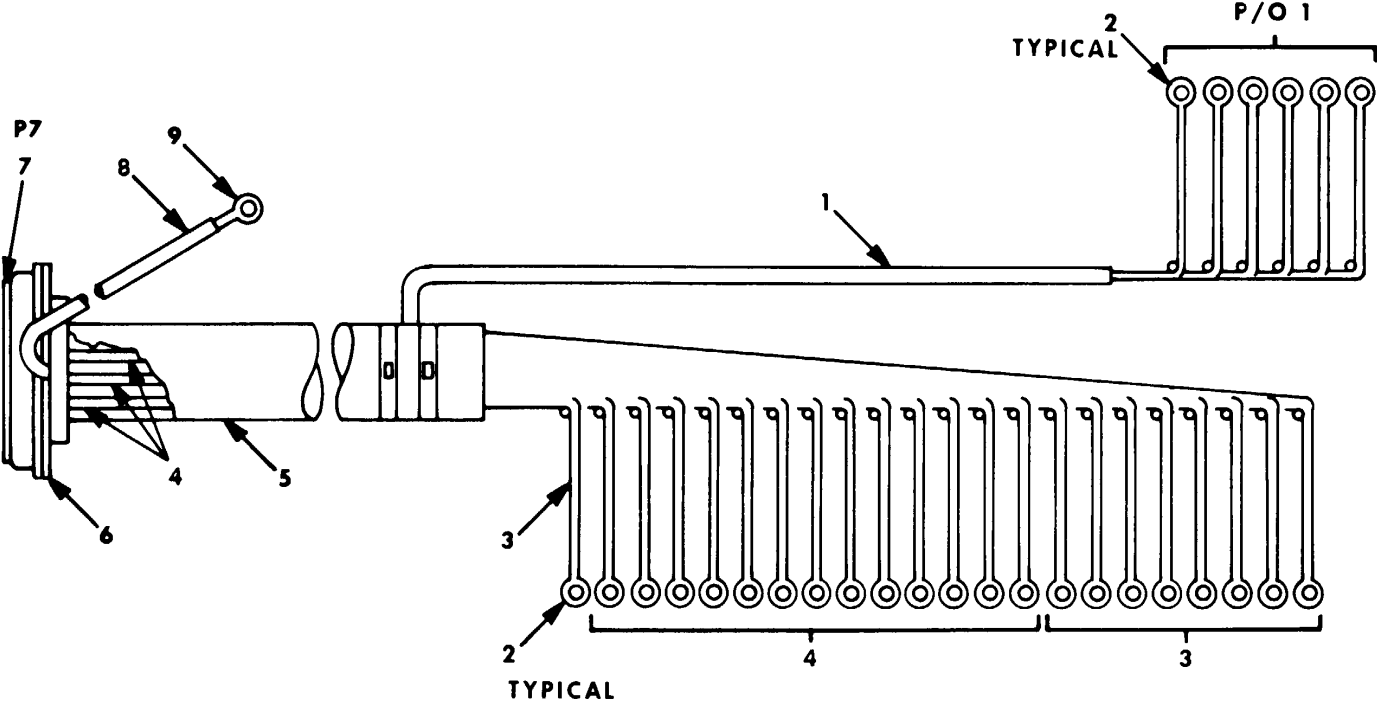

**NOTE: PREFIX ALL REFERENCE DESIGNATIONS WITH
A2W1, A2W2, A2W3, A2W4, A2W6, A2W7.**

EL8SA044

Figure 13. Cable Harness Assembly (Station 1-6) (Sheet 1 of 7).

STATION 1

ITEM NO	FROM	TO	WIRE COLOR	AWG NO	WIRE LG INCHES
1	TB-1(24)	A2W1P7-2	YEL	20	42 1/16
1	TB-1(25)	A2W1P7-23	BLK	20	42 1/2
1	TB-1(26)	A2W1P7-5	WHT	20	42 15/16
1	TB-1(27)	A2W1P7-4	SHD	20	43 3/8
1	TB-1(28)	A2W1P7-22	GRN	20	43 13/16
1	TB-1(29)	A2W1P7-3	RED	20	44 1/4
3	TB-1(22)	A2W1P7-19	WHT	20	41 5/8
3	TB-1(21)	A2W1P7-37	WHT	20	41 3/16
3	TB-1(20)	A2W1P7-36	WHT	20	40 3/4
3	TB-1(19)	A2W1P7-17	WHT	20	40 5/16
3	TB-1(18)	A2W1P7-16	WHT	20	39 7/8
3	TB-1(17)	A2W1P7-15	WHT	20	39 7/16
3	TB-1(16)	A2W1P7-14	WHT	20	39
3	TB-1(15)	A2W1P7-1	WHT	20	38 9/16
4	TB-1(14)	A2W1P7-35	SHD	20	38 1/8
4	TB-1(13)	A2W1P7-34	SHD	20	37 11/16
4	TB-1(12)	A2W1P7-33	SHD	20	37 1/4
4	TB-1(11)	A2W1P7-8	SHD	20	36 13/16
4	TB-1(10)	A2W1P7-6	SHD	20	36 3/8
4	TB-1(9)	A2W1P7-29	SHD	20	35 15/16
4	TB-1(8)	A2W1P7-32	SHD	20	35 1/2
4	TB-1(7)	A2W1P7-31	SHD	20	35 1/16
4	TB-1(6)	A2W1P7-30	SHD	20	34 5/8
4	TB-1(5)	A2W1P7-28	SHD	20	34 3/16
4	TB-1(4)	A2W1P7-26	SHD	20	33 3/4
4	TB-1(3)	A2W1P7-25	SHD	20	33 5/16
4	TB-1(2)	A2W1P7-24	SHD	20	32 7/8
3	TB-1(1)	A2W1P7-9	WHT	20	32 7/16
4	CHASSIS GRD	A2W1P7-11	SHD	20	4
4	CHASSIS GRD	A2W1P7-12	SHD	20	4
4	CHASSIS GRD	A2W1P7-13	SHD	20	4
8	CHASSIS GRD	A2W1P7-18	BRAID	20	20

EL8SA045

Figure 13. Cable Harness Assembly (Station 1-6) (Sheet 2 of 7).

STATION 2

ITEM NO	FROM	TO	WIRE COLOR	AWG NO	WIRE LG INCHES
1	TB-2(24)	A2W2P7-2	YEL	20	42 1/16
1	TB-2(25)	A2W2P7-23	BLK	20	42 1/2
1	TB-2(26)	A2W2P7-5	WHT	20	42 15/16
1	TB-2(27)	A2W2P7-4	SHD	20	43 3/8
1	TB-2(28)	A2W2P7-22	GRN	20	43 13/16
1	TB-2(29)	A2W2P7-3	RED	20	44 1/4
3	TB-2(22)	A2W2P7-19	WHT	20	41 5/8
3	TB-2(21)	A2W2P7-37	WHT	20	41 3/16
3	TB-2(20)	A2W2P7-36	WHT	20	40 3/4
3	TB-2(19)	A2W2P7-17	WHT	20	40 5/16
3	TB-2(18)	A2W2P7-16	WHT	20	39 7/8
3	TB-2(17)	A2W2P7-15	WHT	20	39 7/16
3	TB-2(16)	A2W2P7-14	WHT	20	39
3	TB-2(15)	A2W2P7-1	WHT	20	38 9/16
4	TB-2(14)	A2W2P7-35	SHD	20	38 1/8
4	TB-2(13)	A2W2P7-34	SHD	20	37 11/16
4	TB-2(12)	A2W2P7-33	SHD	20	37 1/4
4	TB-2(11)	A2W2P7-8	SHD	20	36 13/16
4	TB-2(10)	A2W2P7-6	SHD	20	36 3/8
4	TB-2(9)	A2W2P7-29	SHD	20	35 15/16
4	TB-2(8)	A2W2P7-32	SHD	20	35 1/2
4	TB-2(7)	A2W2P7-31	SHD	20	35 1/16
4	TB-2(6)	A2W2P7-30	SHD	20	34 5/8
4	TB-2(5)	A2W2P7-28	SHD	20	34 3/16
4	TB-2(4)	A2W2P7-26	SHD	20	33 3/4
4	TB-2(3)	A2W2P7-25	SHD	20	33 5/16
4	TB-2(2)	A2W2P7-24	SHD	20	32 7/8
3	TB-2(1)	A2W2P7-9	WHT	20	32 7/16
4	CHASSIS GRD	A2W2P7-11	SHD	20	4
4	CHASSIS GRD	A2W2P7-12	SHD	20	4
4	CHASSIS GRD	A2W2P7-13	SHD	20	4
8	CHASSIS GRD	A2W2P7-18	BRAID	20	20

EL8SA046

Figure 13. Cable Harness Assembly (Station 1-6) (Sheet 3 of 7).

STATION 3

ITEM NO	FROM	TO	WIRE COLOR	AWG NO	WIRE LG INCHES
1	TB-3(24)	A2W3P7-2	YEL	20	42 1/16
1	TB-3(25)	A2W3P7-23	BLK	20	42 1/2
1	TB-3(26)	A2W3P7-5	WHT	20	42 15/16
1	TB-3(27)	A2W3P7-4	SHD	20	43 3/8
1	TB-3(28)	A2W3P7122	GRN	20	43 13/16
1	TB-3(29)	A2W3P7-3	RED	20	44 1/4
3	TB-3(22)	A2W3P7-19	WHT	20	41 5/8
3	TB-3(21)	A2W3P7-37	WHT	20	41 3/16
3	TB-3(20)	A2W3P7-36	WHT	20	40 3/4
3	TB-3(19)	A2W3P7-17	WHT	20	40 5/16
3	TB-3(18)	A2W3P7-16	WHT	20	39 7/8
3	TB-3(17)	A2W3P7-15	WHT	20	39 7/16
3	TB-3(16)	A2W3P7-14	WHT	20	39
3	TB-3(15)	A2W3P7-1	WHT	20	38 9/16
4	TB-3(14)	A2W3P7-35	SHD	20	38 1/8
4	TB-3(13)	A2W3P7-34	SHD	20	37 11/16
4	TB-3(12)	A2W3P7-33	SHD	20	37 1/4
4	TB-3(11)	A2W3P7-8	SHD	20	36 13/16
4	TB-3(10)	A2W3P7-6	SHD	20	36 3/8
4	TB-3(9)	A2W3P7-29	SHD	20	35 15/16
4	TB-3(8)	A2W3P7-32	SHD	20	35 1/2
4	TB-3(7)	A2W3P7-31	SHD	20	35 1/16
4	TB-3(6)	A2W3P7-30	SHD	20	34 5/8
4	TB-3(5)	A2W3P7-28	SHD	20	34 3/16
4	TB-3(4)	A2W3P7-26	SHD	20	33 3/4
4	TB-3(3)	A2W3P7-25	SHD	20	33 5/16
4	TB-3(2)	A2W3P7-24	SHD	20	32 7/8
3	TB-3(1)	A2W3P7-9	WHT	20	32 7/16
4	CHASSIS GRD	A2W3P7-11	SHD	20	4
4	CHASSIS GRD	A2W3P7-12	SHD	20	4
4	CHASSIS GRD	A2W3P7-13	SHD	20	4
3	CHASSIS GRD	A2W3P7-18	BRAIL	20	20

EL8SA047

Figure 13. Cable Harness Assembly (Station 1-6) (Sheet 4 of 7).

STATION 4

ITEM NO	FROM	TO	WIRE COLOR	AWG NO	WIRE LG INCHES
1	TB-4(24)	A2W4P7-2	YEL	20	66 1/16
1	TB-4(25)	A2W4P7-23	BLK	20	66 1/2
1	TB-4(26)	A2W4P7-5	WHT	20	66 15/16
1	TB-4(27)	A2W4P7-4	SHD	20	67 3/8
1	TB-4(28)	A2W4P7-22	GRN	20	67 13/16
1	TB-4(29)	A2W4P7-3	RED	20	68 1/4
3	TB-4(22)	A2W4P7-19	WHT	20	65 5/8
3	TB-4(21)	A2W4P7-37	WHT	20	65 3/16
3	TB-4(20)	A2W4P7-36	WHT	20	64 3/4
3	TB-4(19)	A2W4P7-17	WHT	20	64 5/16
3	TB-4(18)	A2W4P7-16	WHT	20	63 7/8
3	TB-4(17)	A2W4P7-15	WHT	20	63 7/16
3	TB-4(16)	A2W4P7-14	WHT	20	63
3	TB-4(15)	A2W4P7-1	WHT	20	62 9/16
4	TB-4(14)	A2W4P7-35	SHD	20	62 1/8
4	TB-4(13)	A2W4P7-34	SHD	20	61 11/16
4	TB-4(12)	A2W4P7-33	SHD	20	61 1/4
4	TB-4(11)	A2W4P7-8	SHD	20	60 13/16
4	TB-4(10)	A2W4P7-6	SHD	20	60 3/8
4	TB-4(9)	A2W4P7-29	SHD	20	59 15/16
4	TB-4(8)	A2W4P7-32	SHD	20	59 1/2
4	TB-4(7)	A2W4P7-31	SHD	20	59 1/16
4	TB-4(6)	A2W4P7-30	SHD	20	58 5/8
4	TB-4(5)	A2W4P7-28	SHD	20	58 3/16
4	TB-4(4)	A2W4P7-26	SHD	20	57 3/4
4	TB-4(3)	A2W4P7-25	SHD	20	57 5/16
4	TB-4(2)	A2W4P7-24	SHD	20	56 7/8
3	TB-4(1)	A2W4P7-9	WHT	20	56 7/16
4	CHASSIS GRD	A2W4P7-11	SHD	20	4
4	CHASSIS GRD	A2W4P7-12	SHD	20	4
4	CHASSIS GRD	A2W4P7-13	SHD	20	4
8	CHASSIS GRD	A2W4P7-18	BRAID	20'	20

EL8SA048

Figure 13. Cable Harness Assembly (Station 1-6) (Sheet 5 of 7).

STATION 5

ITEM NO	FROM	TO	WIRE COLOR	AWG NO	WIRE LG INCHES
1	TB-5(24)	A2W6P7-2	YEL	20	83 1/16
1	TB-5(25)	A2W6P7-23	BLK	20	83 1/2
1	TB-5(26)	A2W6P7-5	WHT	20	83 15/16
1	TB-5(27)	A2W6P7-4	SHD	20	84 3/8
1	TB-5(28)	A2W6P7-22	GRN	20	84 13/16
1	TB-5(29)	A2W6P7-3	RED	20	85 1/4
3	TB-5(22)	A2W6P7-19	WHT	20	82 5/8
3	TB-5(21)	A2W6P7-37	WHT	20	82 3/16
3	TB-5(20)	A2W6P7-36	WHT	20	81 3/4
3	TB-5(19)	A2W6P7-17	WHT	20	81 5/16
3	TB-5(18)	A2W6P7-16	WHT	20	80 7/8
3	TB-5(17)	A2W6P7-15	WHT	20	80 7/16
3	TB-5(16)	A2W6P7-14	WHT	20	80
3	TB-5(15)	A2W6P7-1	WHT	20	79 9/16
4	TB-5(14)	A2W6P7-35	SHD	20	79 1/8
4	TB-5(13)	A2W6P7-34	SHD	20	78 11/16
4	TB-5(12)	A2W6P7-33	SHD	20	78 1/4
4	TB-5(11)	A2W6P7-8	SHD	20	77 13/16
4	TB-5(10)	A2W6P7-6	SHD	20	77 3/8
4	TB-5(9)	A2W6P7-29	SHD	20	76 15/16
4	TB-5(8)	A2W6P7-32	SHD	20	76 1/2
4	TB-5(7)	A2W6P7-31	SHD	20	76 1/16
4	TB-5(6)	A2W6P7-30	SHD	20	75 5/8
4	TB-5(5)	A2W6P7-28	SHD	20	75 3/16
4	TB-5(4)	A2W6P7-26	SHD	20	74 3/4
4	TB-5(3)	A2W6P7-25	SHD	20	74 5/16
4	TB-5(2)	A2W6P7-24	SHD	20	73 7/8
3	TB-5(1)	A2W6P7-9	WHT	20	73 7/16
4	CHASSIS GRD	A2W6P7-11	SHD	20	4
4	CHASSIS GRD	A2W6P7-12	SHD	20	4
4	CHASSIS GRD	A2W6P7-13	SHD	20	4
8	CHASSIS GRD	A2W6P7-18	BRAID	20	20

EL8SA049

Figure 13. Cable Harness Assembly (Station 1-6) (Sheet 6 of 7).

STATION 6

ITEM NO	FROM	TO	WIRE COLOR	AWG NO	WIRE LG INCHES
1	TB-6(24)	A2W7P7-2	YEL	20	83 1/16
1	TB-6(25)	A2W7P7-23	BLK	20	83 1/2
1	TB-6(26)	A2W7P7-5	WHT	20	83 15/16
1	TB-6(27)	A2W7P7-4	SHD	20	84 3/8
1	TB-6(28)	A2W7P7-22	GRN	20	84 13/16
1	TB-6(29)	A2W7P7-3	RED	20	85 1/4
3	TB-6(22)	A2W7P7-19	WHT	20	82 5/8
3	TB-6(21)	A2W7P7-37	WHT	20	82 3/16
3	TB-6(20)	A2W7P7-36	WHT	20	81 3/4
3	TB-6(19)	A2W7P7-17	WHT	20	81 5/16
3	TB-6(18)	A2W7P7-16	WHT	20	80 7/8
3	TB-6(17)	A2W7P7-15	WHT	20	80 7/16
3	TB-6(16)	A2W7P7-14	WHT	20	80
3	TB-6(15)	A2W7P7-1	WHT	20	79 9/16
4	TB-6(14)	A2W7P7-35	SHD	20	79 1/8
4	TB-6(13)	A2W7P7-34	SHD	20	78 11/16
4	TB-6(12)	A2W7P7-33	SHD	20	78 1/4
4	TB-6(11)	A2W7P7-8	SHD	20	77 13/16
4	TB-6(10)	A2W7P7-6	SHD	20	77 3/8
4	TB-6(9)	A2W7P7-29	SHD	20	76 15/16
4	TB-6(8)	A2W7P7-32	SHD	20	76 1/2
4	TB-6(7)	A2W7P7-31	SHD	20	76 1/16
4	TB-6(6)	A2W7P7-30	SHD	20	75 5/8
4	TB-6(5)	A2W7P7-28	SHD	20	75 3/16
4	TB-6(4)	A2W7P7-26	SHD	20	74 3/4
4	TB-6(3)	A2W7P7-25	SHD	20	74 5/16
4	TB-6(2)	A2W7P7-24	SHD	20	73 7/8
3	TB-6(1)	A2W7P7-9	WHT	20	73 7/16
4	CHASSIS GRD	A2W7P7-11	SHD	20	4
4	CHASSIS GRD	A2W7P7-12	SHD	20	4
4	CHASSIS GRD	A2W7P7-13	SHD	20	4
8	CHASSIS GRD	A2W7P7-18	BRAID	20	20

EL8SA050

Figure 13. Cable Harness Assembly (Station 1-6) (Sheet 7 of 7).

SECTION II

TM 11-5821-285-30P

(1) ILLUSTRATION		(2)	(3)	(4)	(5)	(6)	(7)	(8)
(a) FIG NO.	(b) ITEM NO.	SMR CODE	NATIONAL STOCK NUMBER	FSCM	PART NUMBER	DESCRIPTION USABLE ON CODE	U/M	QTY INC IN UNIT
						GROUP 12 CABLE HARNESS ASSEMBLY (STATION 1-6)		
13	1	MFFZZ		80063	SC-D-972700-6	CABLE, SPECIAL PURPO MAKE FROM 6145-00-635-1536		FTV
13	2	PAFZZ	5940-00-204-8966	96906	MS25036-102	TERMINAL, LUG	EA	6
13	3	MFFZZ		80063	SC-D-972700-4	WIRE ELEC 20 AWG MAKE FROM 81349 MILW16878-4BGE9	FT	V
13	4	MFFZZ		80063	SC-D-972700-1	CABLE SPECIAL PRP MAKE FROM 81349 MILW16878-4BGES9	FT	V
13	5	MFFZZ		80063	SC-D-972700-1	INSULATION SLEEVE MAKE FROM 5970-00-892-0939	FT	V
13	6	PAFZZ		96906	MS24308-21-4	CONNECTOR RCPT	EA	1
13	7	PAFZZ		71468	DCMA-37S-C33	CONNECTOR, PLUG, ELEC	EA	1
13	8	MFFZZ		80063	SC-D-972700-5	BRAID, WIRE MAKE FROM 6145-00-184-0666	FT	V
13	9	PAFZZ	5940-00-557-1629	96906	MS25036-149	TERMINAL, LUG	EA	1
					77			

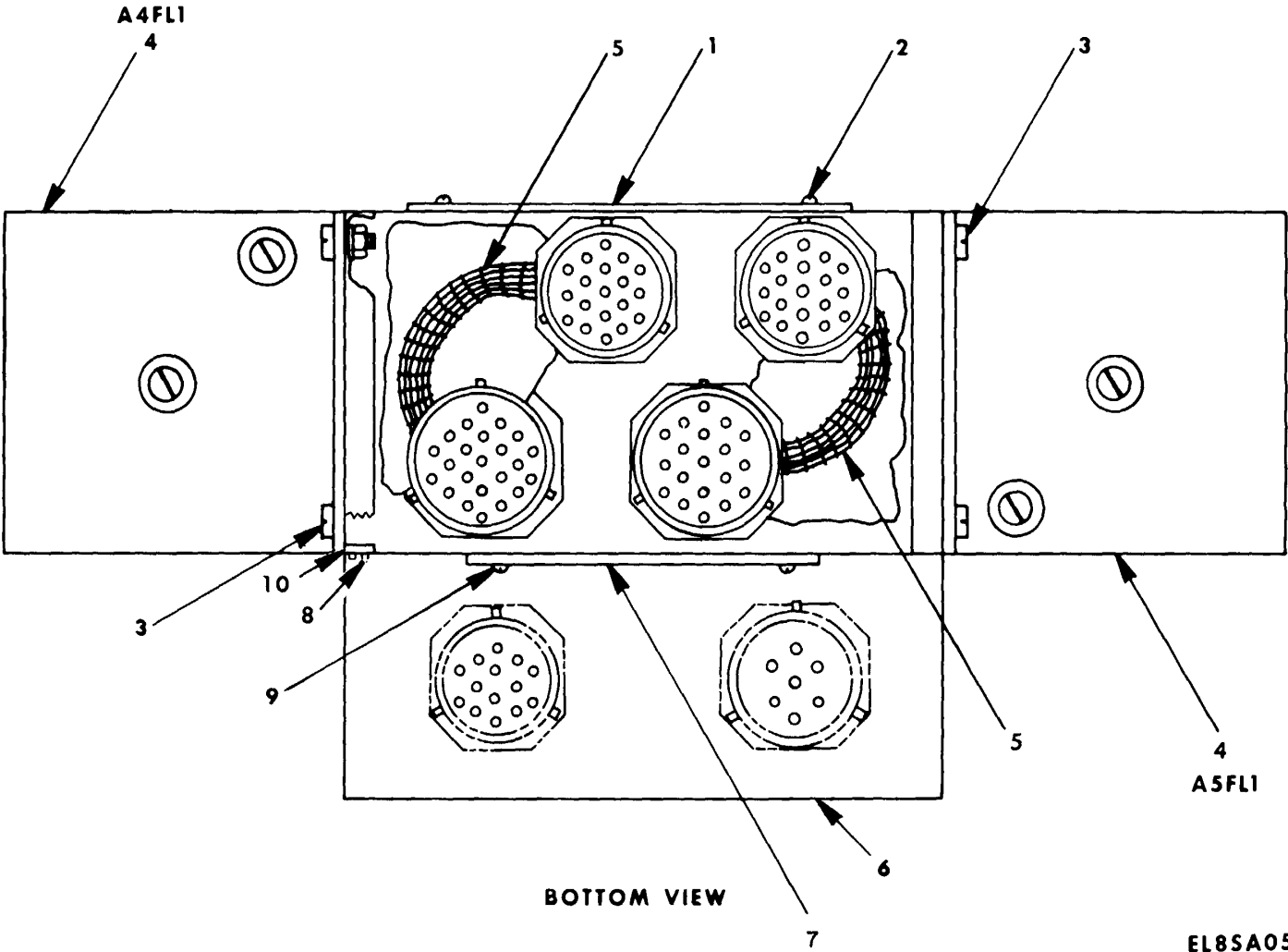
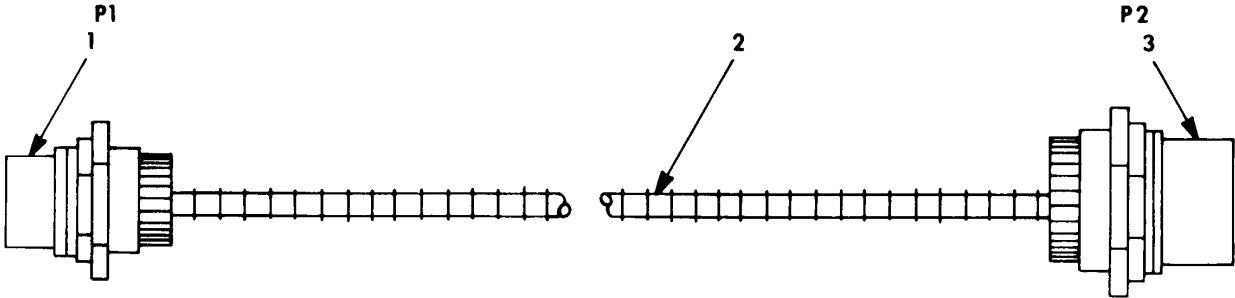

Figure 14. Connector Cover and Bracket Assembly KY-28.

SECTION II

TM 11-5821-285-30P

(1) ILLUSTRATION		(2)	(3)	(4)	(5)	(6) DESCRIPTION	(7)	(8)
(a) FIG NO.	(b) ITEM NO.	SMR CODE	NATIONAL STOCK NUMBER	FSCM	PART NUMBER	USABLE ON CODE	U/M	QTY INC IN UNIT
						GROUP 14 CONNECTOR AND COVER ASSEMBLY KY-28		
14	1	XBFZZ		80063	SC-C-972647	PLATE IDENT.....	EA	1
14	2	PAFZL	5305-00-993-0190	96906	MS35206-214	SCREW, MACHINE.....	EA	4
14	3	PAFZZ	5305-00-984-6193	96906	MS35206-245	SCREW, MACHINE.....	EA	8
14	4	PAFZZ	5915-00-937-9997	56289	JN17-3346A	FILTER, RADIO FREQUE.....	EA	2
14	5	AFFFF		80063	SC-C-972622	CABLE ASSY SEE FIG 15 FOR PARTS.....	EA	2
						GROUP 1401 BRACKET ASSEMBLY		
14	6	XRFFF		80063	SC-D-972615	BRACKET ASSY.....	EA	1
14	7	XBFZZ		80063	SC-C-972644	PLATE IDENT.....	EA	1
14	8	PAFZZ	5320-00-845-7751	96906	MS20427-3C5	RIVET, SOLID.....	EA	14
14	9	PAFZZ	5305-00-993-0190	96906	MS35206-214	SCREW, MACHINE.....	EA	2
14	10	XBFZZ		80063	SC-B-972619	TAB COVER SET.....	EA	1
					79			



ITEM NO.	FROM	TO	WIRE COLOR	AWG NO.	WIRE LG. INCHES
2	FM-1 P1-A	FM-1 P2-V	WHT	20	6
2	FM-1 P1-F	FM-1 P2-G	WHT	20	6
2	FM-1 P1-K	FM-1 P2-S	WHT	20	6
2	FM-2 P1-A	FM-2 P2-V	WHT	20	6
2	FM-2 P1-F	FM-2 P2-G	WHT	20	6
2	FM-2 P1-K	FM-2 P2-S	WHT	20	6

NOTE: PREFIX ALL REFERENCE DESIGNATIONS WITH FM-1, FM-2.

EL8SA052

Figure 15. Cable Assembly.

SECTION II

TM 11-5821-285-30P

(1) ILLUSTRATION		(2)	(3)	(4)	(5)	(6)	(7)	(8)
(a) FIG NO.	(b) ITEM NO.	SMR CODE	NATIONAL STOCK NUMBER	FSCM	PART NUMBER	DESCRIPTION USABLE ON CODE	U/M	QTY INC IN UNIT
15	1	PAFZZ	5935-00-902-2344	96906	MS3124EI2-10P	GROUP 1402 CABLE ASSEMBLY CONNECTOR, RECEPTAC.....	EA	1
15	2	MFFZZ		81349	M1LW16878-4BGE9	WIRE ELEC 20 AWG MAKE FROM 81349 MILW16878-4BGE9.....	FT	V
15	3	PAFZZ	5935-00-880-8890	96906	MS3124E16-26PW	CONNECTOR, RECEPTAC.....	EA	1
81/(82 blank)								

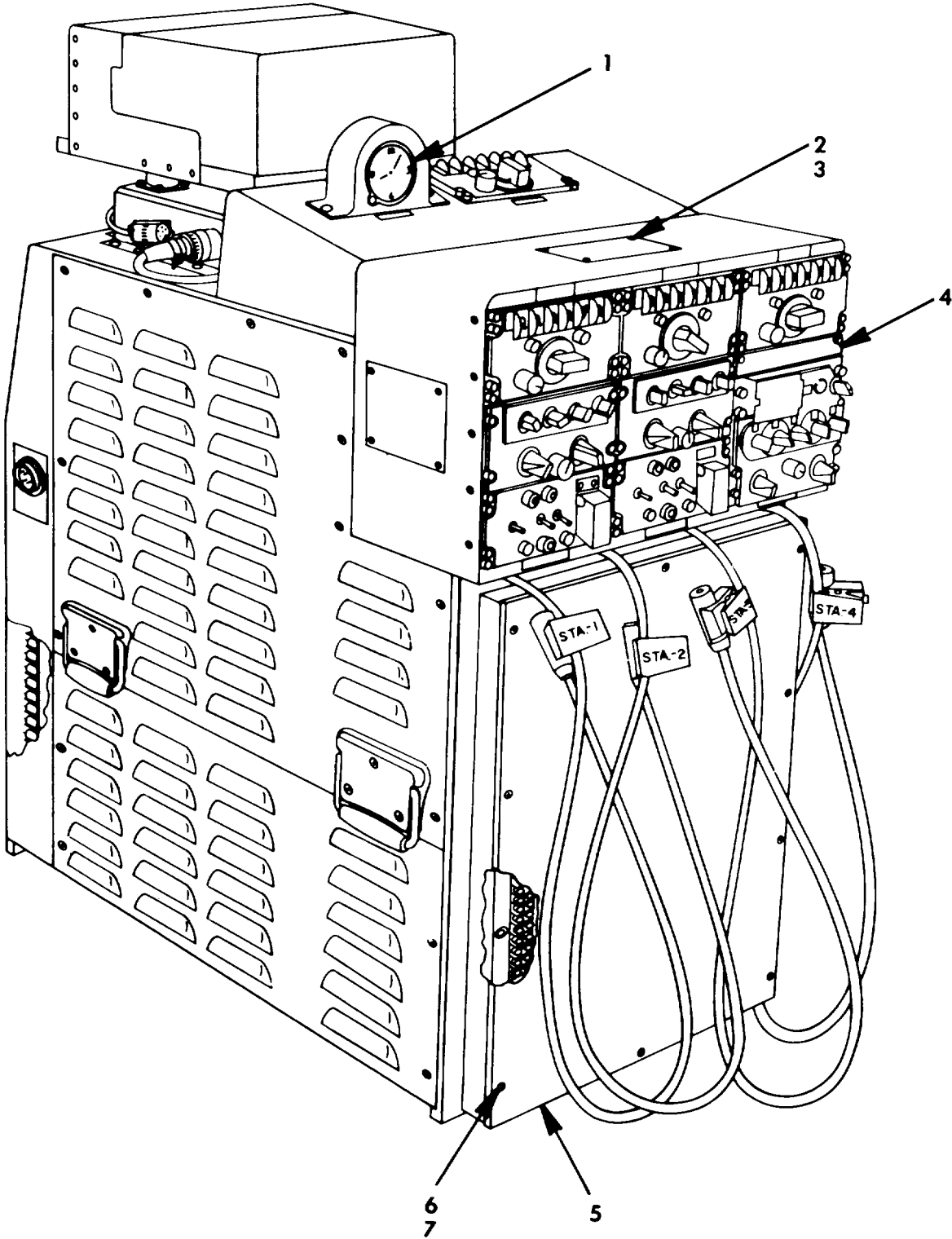

EL85A053

Figure 16. Frame Assembly (V1 and 2 (Sheet 1 of 6).

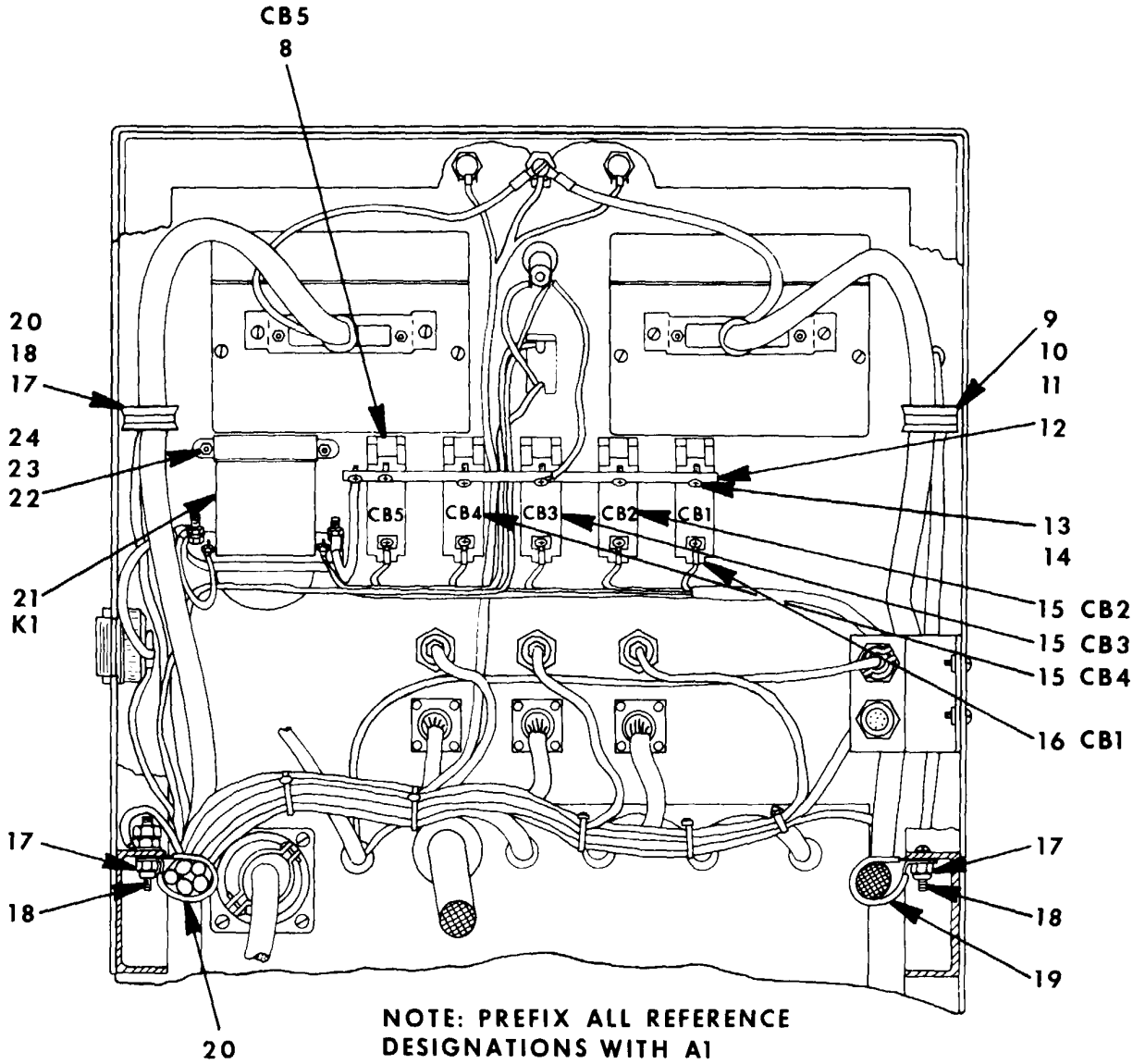
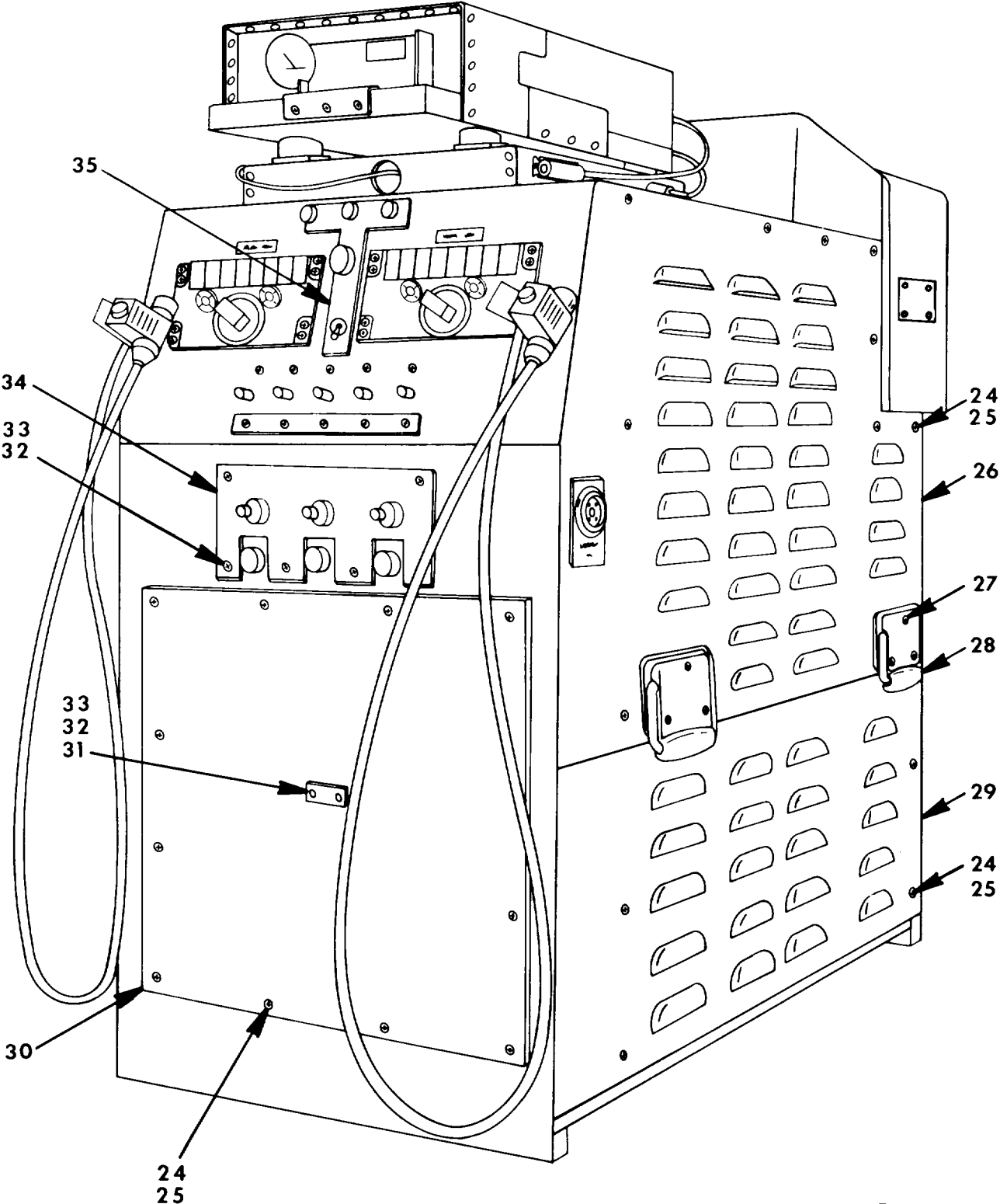
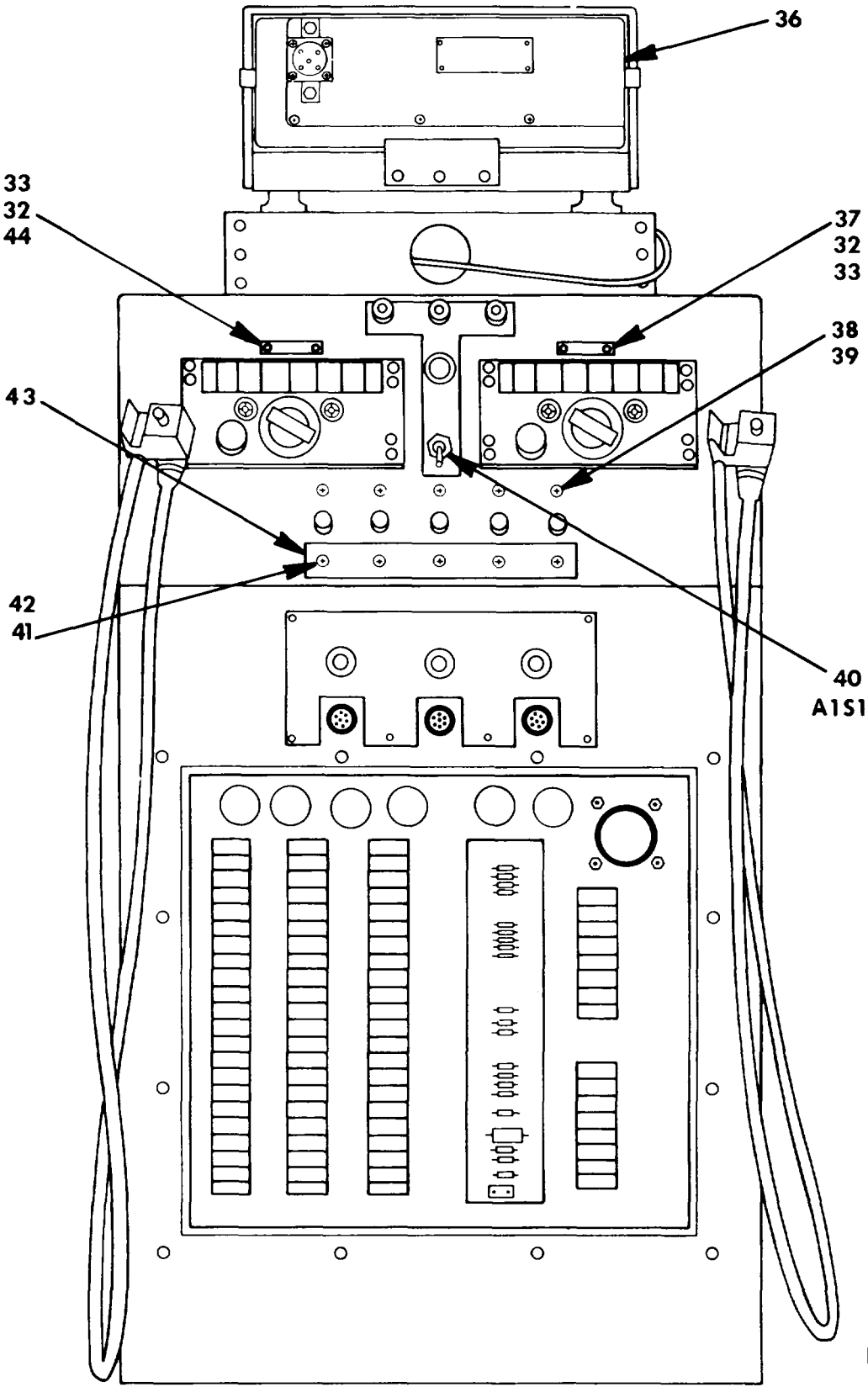

Figure 16. Frame Assembly (V)1 and 2 (Sheet 2 of 6).



EL8SA055

Figure 16. Frame Assembly (V1 and 2 (Sheet 3 of 6).



EL8SA056

Figure 16. Frame Assembly (V)1 and 2 (Sheet 4 of 6).

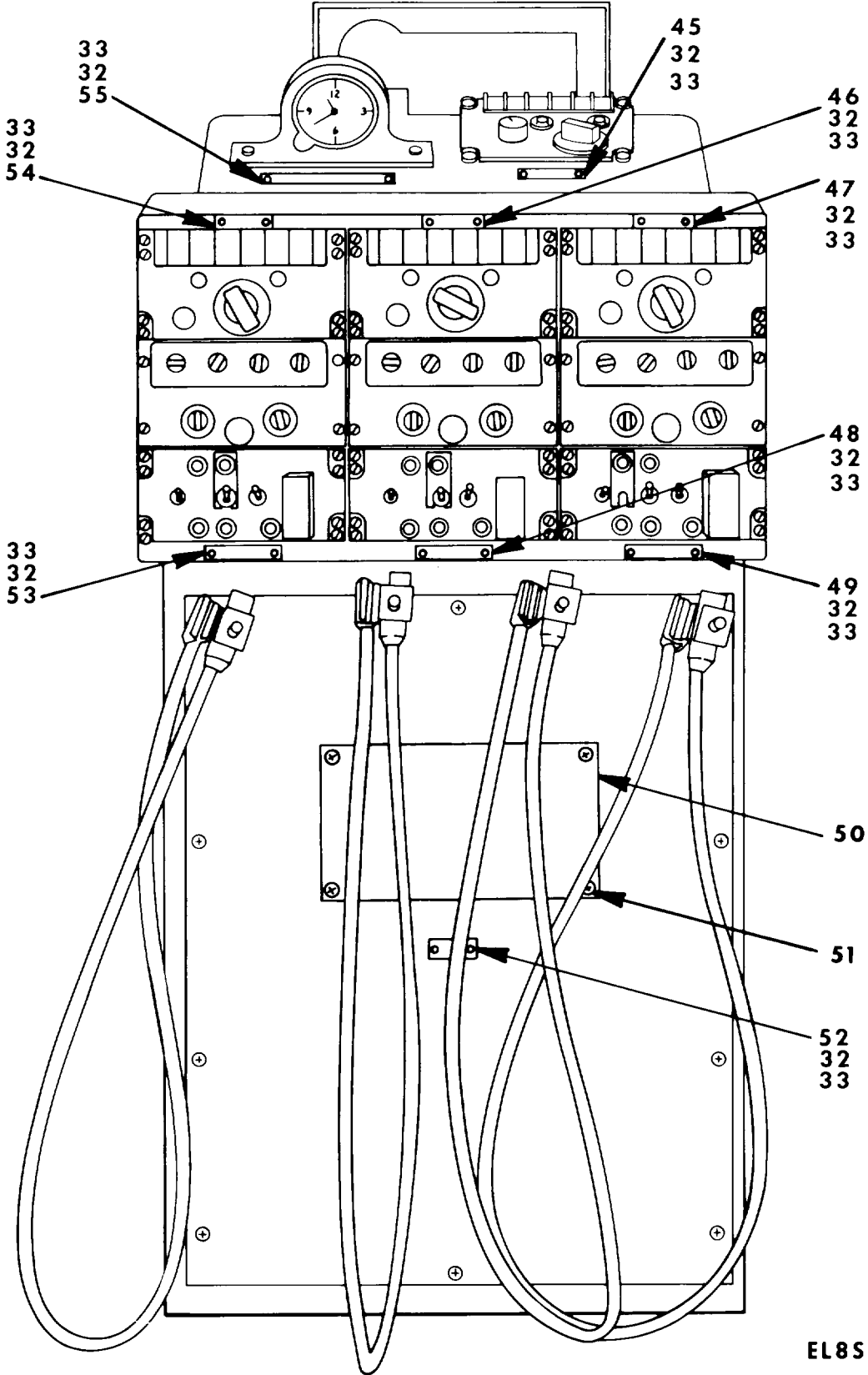

EL8SA057

Figure 16. Frame Assembly (V1 and 2 (Sheet 5 of 6).

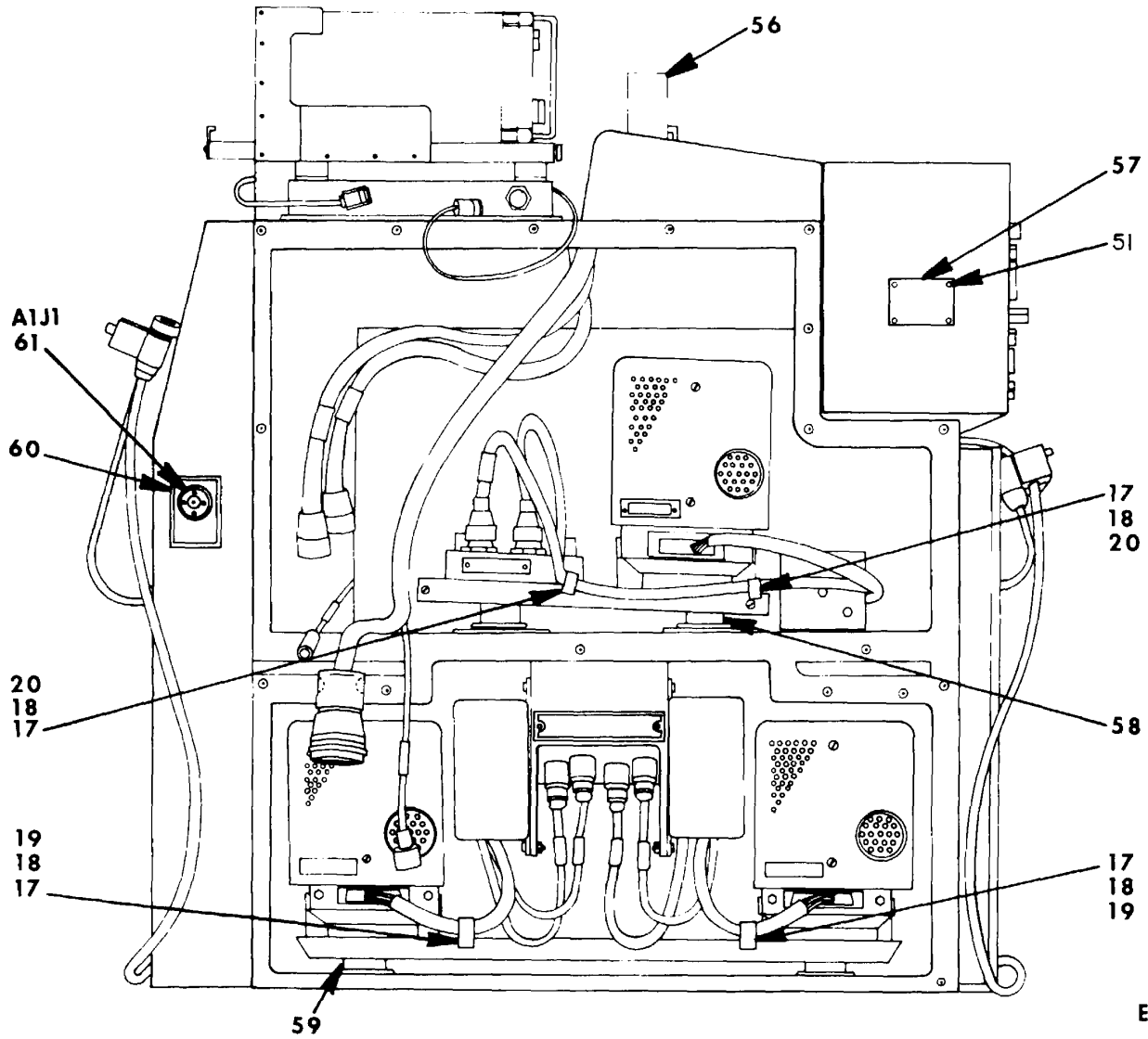

EL85A058

Figure 16. Frame Assembly (V)1 and 2 (Sheet 6 of 6).

SECTION II

TM 11-5821-285-30P

(1) ILLUSTRATION		(2)	(3)	(4)	(5)	(6)	(7)	(8)
(a) FIG NO.	(b) ITEM NO.	SMR CODE	NATIONAL STOCK NUMBER	FSCM	PART NUMBER	DESCRIPTION USABLE ON CODE	U/M	QTY INC IN UNIT
						GROUP 17 FRAME ASSEMBLY V1 AND V2		
16	1	PAFZZ		81349	MILC6499TYPE A13A	CLOCK AIRCRAFT.....	EA	1
16	2	XBFZZ		80063	SC-C-972678	PLATE NAME.....	EA	1
16	3	PAFZZ		80063	SC-C-972650-9	SCREW SELF-TAPPING.....	EA	8
16	4	XBFZZ		80063	SC-C-972729	PANEL BLANK ASSY.....	EA	1
16	5	XBOZZ		80063	SC-C-972666	COVER BOX.....	EA	1
16	6	PAOZZ	5305-00-984-6195	96906	MS35206-247	SCREW, MACHINE.....	EA	10
16	7	PAOZZ	5310-00-045-3299	96906	MS35338-42	WASHER, LOCK.....	EA	10
16	8	PAFZZ	5925-00-173-7155	96906	MS25017-10	CIRCUIT BREAKER.....	EA	1
16	9	PAFZZ	5340-00-598-0415	96906	MS21919DG18	CLAMP, LOOP.....	EA	12
16	10	PAFZZ	5310-00-807-1466	96906	MS21042-08	NUT, SELF-LOCKING, EX.....	EA	12
16	11	PAFZZ	5305-00-984-6193	96906	MS35206-245	SCREW, MACHINE.....	EA	12
16	12	XBOZZ		80063	SC-C-972721	BUSS BAR.....	EA	1
16	13	PAFZZ	5305-00-954-0942	96906	MS35206-331	SCREW, MACHINE.....	EA	12
16	14	PAFZZ	5310-00-061-0004	96906	MS45904-57	WASHER, LOCK.....	EA	5
16	15	XAFZZ		96906	MS25017-15	CIRCUIT BREAKER.....	EA	3
16	16	PAFZZ	5925-00-173-7158	96906	MS25017-5	CIRCUIT BREAKER.....	EA	1
16	17	PAFZZ	5310-00-807-1466	96906	MS21042-08	NUT, SELF-LOCKING, EX.....	EA	5
16	18	PAFZZ	5305-00-984-6193	96906	MS35206-245	SCREW, MACHINE.....	EA	13
16	19	PAFZZ	5340-00-200-2729	96906	MS21919DG-14	CLAMP, LOOP.....	EA	8
16	20	PAFZZ	5340-00-286-9418	96906	MS21919DG16	CLAMP, LOOP.....	EA	5
16	21	PAFZZ		81348	6041H80A	RELAY ARMATURE.....	EA	1
16	22	PAFZZ	5305-00-988-1727	96906	MS35206-283	SCREW, MACHINE.....	EA	2
16	23	PAFZZ	5310-00-807-1468	96906	MS21042-4	NUT, SELF-LOCKING, EX.....	EA	2
16	24	PAFZZ	5310-00-045-3299	96906	MS35338-42	WASHER, LOCK.....	EA	12
16	25	PAFZZ	5305-00-984-6195	96906	MS35206-247	SCREW, MACHINE.....	EA	12
16	26	XBFZZ		80063	SC-D-972695	PANEL RIGHT SIDE.....	EA	1
16	27	PAFZZ	5305-00-225-3850	96906	MS35203-59	SCREW, MACHINE.....	EA	12
16	28	PAFZZ	5340-00-664-4051	80063	SC-D-9824	HANDLE, BAIL.....	EA	4
16	29	XBFZZ		80063	SC-D-972696	PANEL RIGHT SIDE.....	EA	1
16	30	XBOZZ		80063	SC-D-972683	BOX COVER WELD ASSY.....	EA	1
16	31	XBFZZ		80063	SC-B-972684	PLATE NAME.....	EA	1
16	32	PAFZZ	5310-00-058-1823	96906	MS21042-02	NUT, SELF-LOCKING, EX.....	EA	24
16	33	PAFZZ	5305-00-889-3118	96906	MS35206-203	SCREW, MACHINE.....	EA	24
16	34	XBFZZ		80063	SC-C-972650-4	PLATE NAME.....	EA	1
16	35	XBFZZ		80063	SC-C-972686	PLATE NAME.....	EA	1
16	36	PDDDD	6130-00-252-0004	80058	U383VR	ADAPTER, POWER SUPPL.....	EA	1
16	37	XBFZZ		80063	SC-B-972690	PLATE NAME.....	EA	1
16	38	PAFZZ	5305-00-984-4988	96906	MS35206-25	SCREW, MACHINE.....	EA	5
16	39	PAFZZ	5310-00-045-4007	96906	MS35338-41	WASHER, LOCK.....	EA	5

SECTION II

TM 11-5821-285-30P

(1) ILLUSTRATION		(2)	(3)	(4)	(5)	(6) DESCRIPTION	(7)	(8)
(a) FIG NO.	(b) ITEM NO.	SMR CODE	NATIONAL STOCK NUMBER	FSCM	PART NUMBER	USABLE ON CODE	U/M	QTY INC IN UNIT
16	40	PAFZZ	5930-00-615-7896	96906	MS25098-22	SWITCH, TOGGLE	EA	1
16	41	PAFZZ	5310-00-045-3299	96906	MS35338-42	WASHER, LOCK	EA	5
16	42	PAFZZ	5305-00-954-0942	96906	MS35206-331	SCREW, MACHINE	EA	5
16	43	XBFZZ		80063	SC-B-972688	PLATE NAME	EA	1
16	44	XBFZZ		80063	SC-B-972689	PLATE NAME	EA	1
16	45	XBFZZ		80063	SC-B-972694	PLATE NAME	EA	1
16	46	XBFZZ		80063	SC-B-972670	PLATE NAME	EA	1
16	47	XBFZZ		80063	SC-B-972671	PLATE NAME	EA	1
16	48	XBFZZ		80063	SC-B-972673	PLATE NAME	EA	1
16	49	XBFZZ		80063	SC-B-972674	PLATE NAME	EA	1
16	50	XBFZZ		80063	SC-C-972667	PLATE WARNING	EA	1
16	51	PAFZZ	5305-00-140-8001	96906	MS51861-12	SCREW, TAPPING, THREA.....	EA	8
16	52	XBFZZ		80063	SC-B-972668	PLATE NAME	EA	1
16	53	XBFZZ		80063	SC-B-972672	PLATE NAME	EA	1
16	54	XBFZZ		80063	SC-B-972669	PLATE NAME	EA	1
16	55	XBFZZ		80063	SC-B-972693	PLATE NAME	EA	2
16	56	XBFZZ		80063	SC-C-972691	BRACKET ASSY CLOCK	EA	1
16	57	XBFZZ		80063	SC-C-972677	PLATE WARNING	EA	2
16	58	PAFZZ		81860	B64-BB-20	MOUNT RESILIENT	EA	4
16	59	PAFZZ		81860	B64-BB-40	MOUNT RESILIENT	EA	4
16	60	XBFZZ		80063	SC-B-972687	PLATE NAME	EA	1
16	61	PAFZZ	5935-00-201-3998	81349	UW2020MA0	CONNECTOR, RECEPTACLE	EA	1

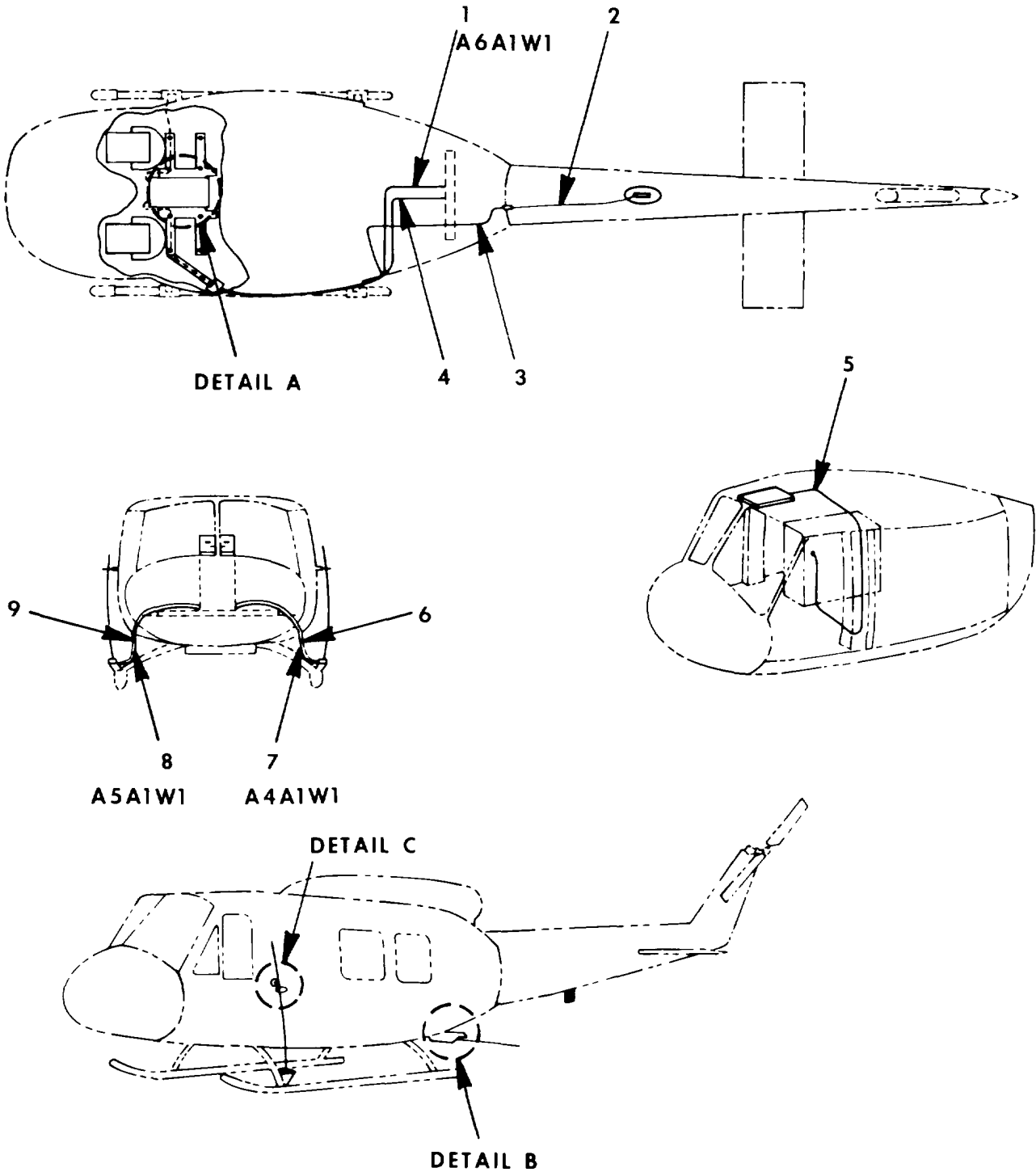

EL8SA059

Figure 17. AN/ASC-15A V1 and V2 Installation Kit UH-1D/H (Sheet 1 of 4).

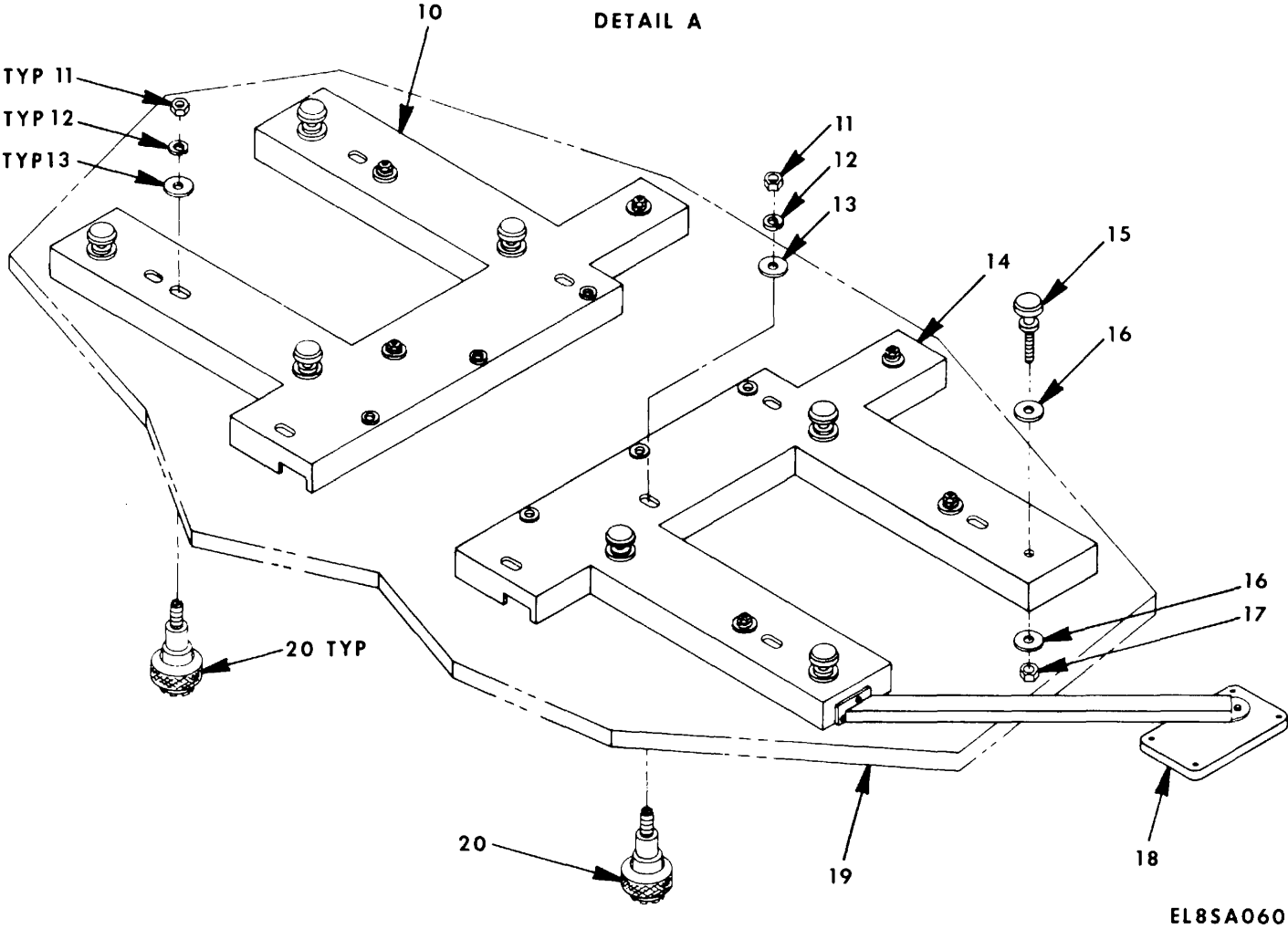
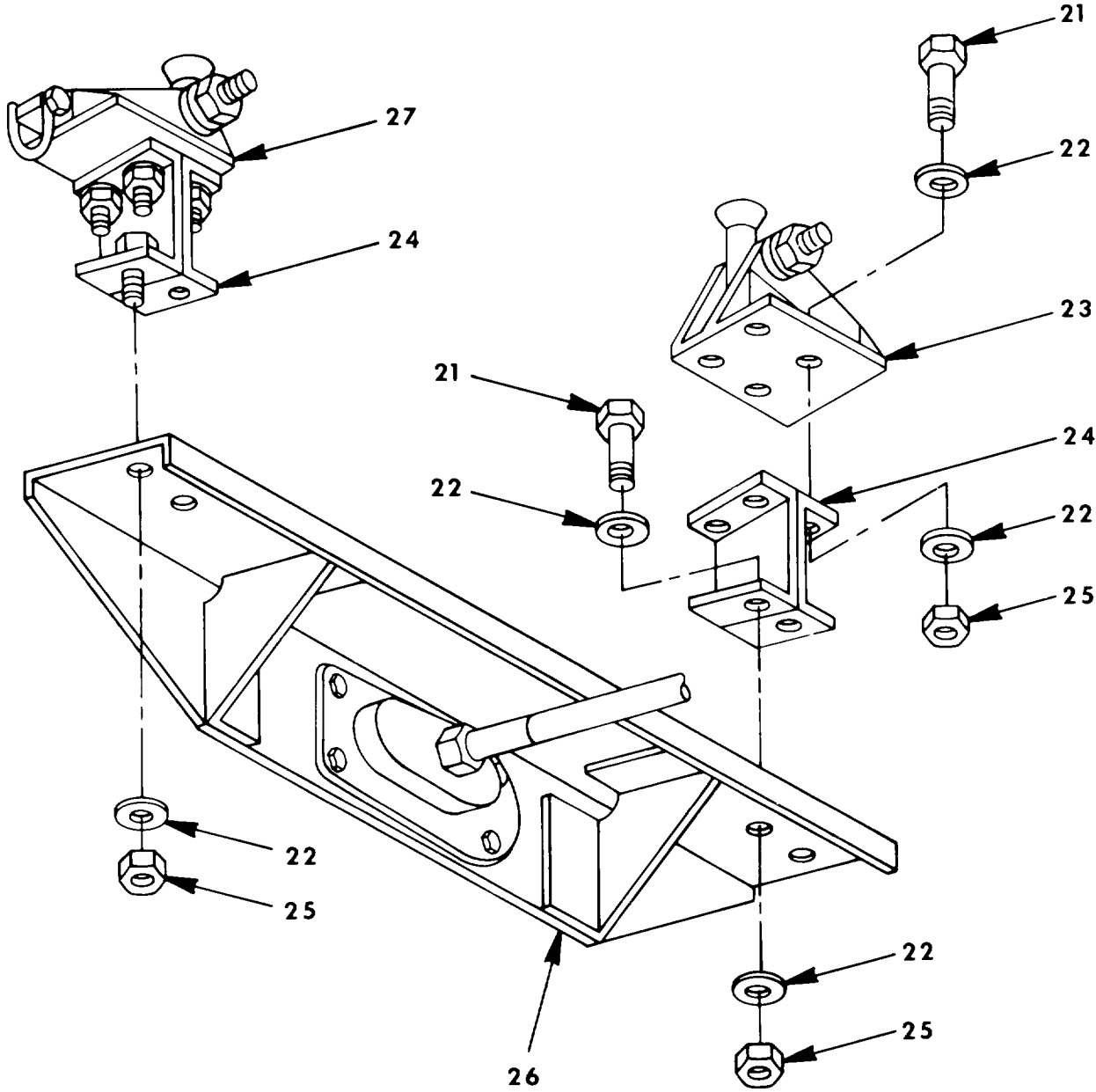
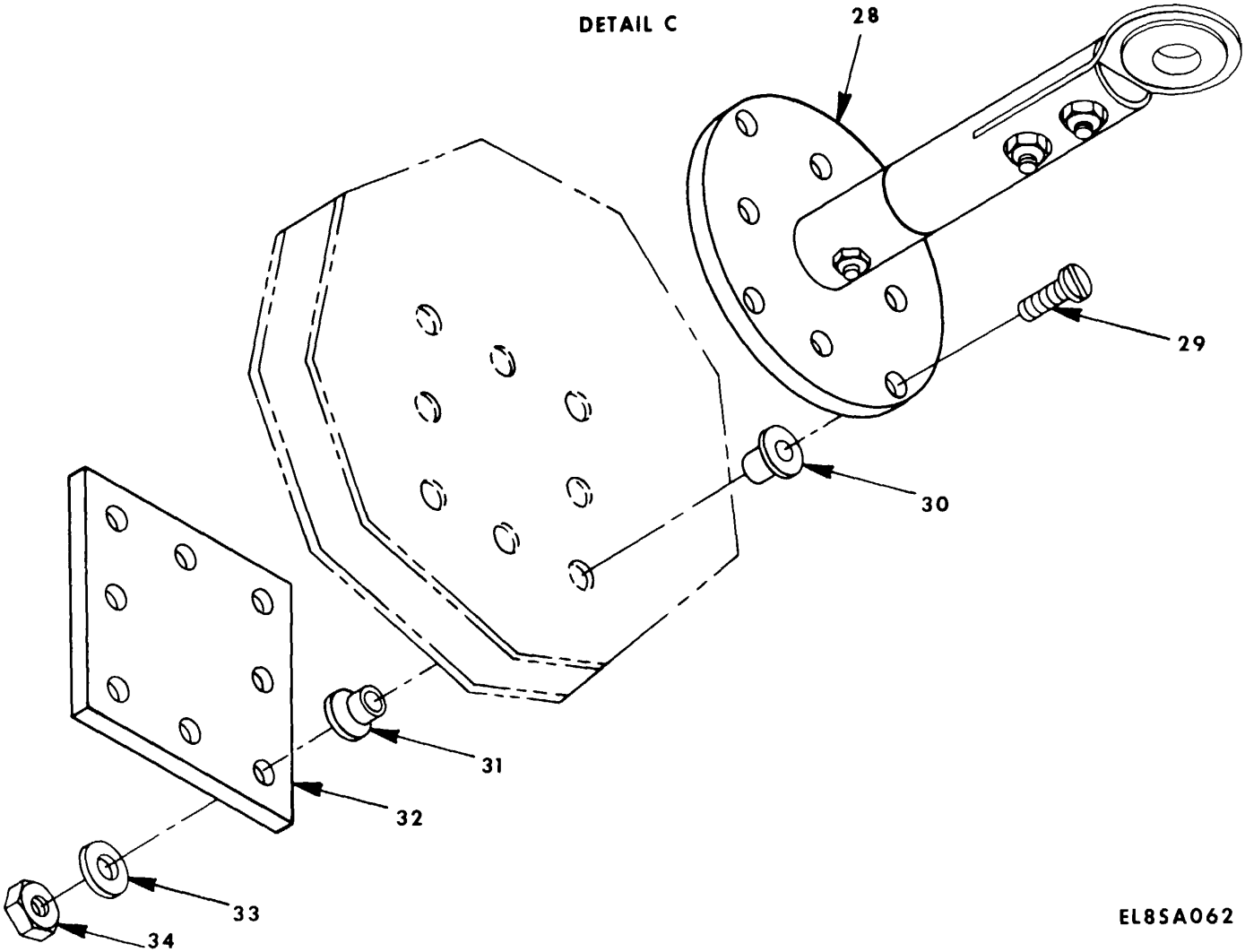

Figure 17. AN/ASC-15A V1 and V2 Installation Kit UH-1D/H (Sheet 2 of 4).



EL85A061

Figure 17. AN/ASC-15A V1 and V2 Installation Kit UH-1D/H (Sheet 3 of 4).



EL85A062

Figure 17. AN/ASC-15A V1 and V2 Installation Kit UH-1D/H (Sheet 4 of 4).

SECTION II

TM 11-5821-285-30P

(1) ILLUSTRATION		(2)	(3)	(4)	(5)	(6) DESCRIPTION	(7)	(8)
(a) FIG NO.	(b) ITEM NO.	SMR CODE	NATIONAL STOCK NUMBER	FSCM	PART NUMBER	USABLE ON CODE	U/M	QTY INC IN UNIT
						GROUP 18 AN/ASC-15A(V)1 AND (V)2 INSTALLATION KIT UH-ID/H		
17	1	AFFFF		80063	SC-C-972786	CABLE ASSY FM-3 SEE FIG. 19 FOR PARTS	EA	1
17	2	AFFFF		80063	SC-C-972787	CABLE ASSY SEE FIG. 18 FDR PARTS.....	EA	1
17	3	AFFFF		80063	SC-C-972788	CABLE ASSY SEE FIG. 18 FOR PARTS	EA	1
17	4	AFFFF		80063	SC-D-972791	CABLE CONT CPLR FP3 SEE FIG. 20 FOR PARTS .	EA	1
17	5	AFFFF		80063	SC-D-972780	CABLE POWER ASSY SEE FIG. 21 FOR PARTS	EA	1
17	6	AFFFF		80063	SC-D-972789	CABLE CONT CPLR FM1 SEE FIG. 20 FOR PARTS	EA	1
17	7	AFFFF		80063	SC-C-972784	CABLE ASSY FM-1 SEE FIG. 19 FOR PARTS	EA	1
17	8	AFFFF		80063	SC-D-972785	CABLE ASSY FM-2 SEE FIG. 19 FOR PARTS	EA	1
17	9	AFFFF		80063	SC-D-972790	CABLE CONT CPLR FM2 SEE FIG. 20 FOR PARTS	EA	1
17	10	XBFZZ		80063	SC-D-972731	FRAME MOUNT ASSY L.....	EA	1
17	11	PAFZZ	5310-00-732-0560	96906	MS51968-14	NUT, PLAIN, HEXAGON	EA	8
17	12	PAFZZ	5310-00-637-9541	96906	MS35338-46	WASHER, LOCK	EA	8
17	13	PAFZZ	5310-00-066-5014	78286	S1535-61262-4	WASHER, FLAT	EA	8
17	14	XBFZZ		80063	SC-D-972733	FRAME MOUNT ASSY R	EA	1
17	15	XBFZZ		80063	SC-C-972736	STUD	EA	4
17	16	PAFZZ	5310-00-773-7618	96906	MS15795-814	WASHER, FLAT	EA	8
17	17	PAFZZ	5310-00-087-4652	96906	MS51922-17	NUT, SELF-LOCKING, HE	EA	4
17	18	XBFZZ		80063	SC-C-972753	PLATE ASSY CABLE	EA	1
17	19	XBFZZ		80063	SC-D-972749	DUCT CABLE ASSY	EA	1
17	20	XBFZZ		80063	SC-C-972755	STUD FITTING (MOD).....	EA	8
17	21	PAFZZ	5306-00-151-1426	88044	AN-4-6-A	BOLT, MACHINE	EA	12
17	22	PAFZZ	5310-00-531-9515	88044	AN960-C416	WASHER, FLAT	EA	24
17	23	XPFZZ		80063	SC-D-972777	BRACKET ADAPTER R	EA	1
17	24	XBFZZ		80063	SC-C-972774	BRACKET ASS ANT	EA	2
17	25	PAFZZ	5310-00-959-7600	96906	MS51922-5	NUT, SELF-LOCKING, HE	EA	24
17	26	XBFZZ		80063	SC-D-972794	BRACKET UHI-D	EA	1
17	27	XBFZZ		80063	SC-D-972778	BRACKET ADAPTER L	EA	1
17	28	XBFFF		80063	SC-C-972737	STAND-OFF ASSY ANT	EA	1
17	29	PAFZZ	5305-00-984-6221	96906	MS35206-234	SCREW, MACHINE	EA	8
17	30	PAFZZ	5325-00-147-6442	29372	P102F-6-1	FASTENER, PANEL	EA	8
17	31	PAFZZ		29372	5102F6-04	FASTENER PANEL	EA	8
17	32	XBFZZ		80063	SC-C-972741	PLATE BACKUP	EA	1
17	33	PAFZZ	5310-00-638-9857	88044	AN960C6L	WASHER, FLAT	EA	8
17	34	PAFZZ	5310-00-081-8087	96906	MS21044N06	NUT, SELF-LOCKING, HE	EA	8

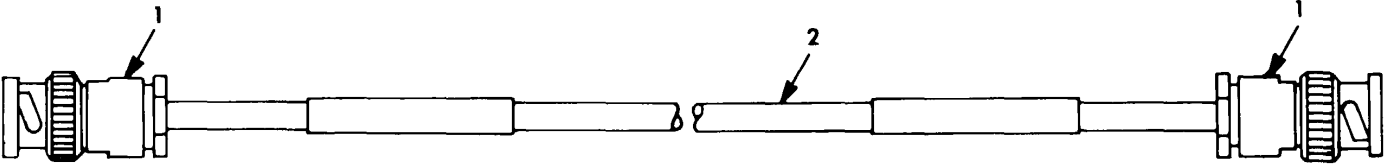

ITEM NO.	FROM	TO	WIRE COLOR	AWG NO.	WIRE LG. INCHES
2	UG-88E/U	UG-88E/U	COAX CABLE	RG58	72
2	UG-88E/U	UG-88E/U	COAX CABLE	RG58	288

EL8SA063

Figure 18. Cable Assembly Coax.

SECTION II

TM 11-5821-285-30P

(1) ILLUSTRATION		(2)	(3)	(4)	(5)	(6)	(7)	(8)
(a) FIG NO.	(b) ITEM NO.	SMR CODE	NATIONAL STOCK NUMBER	FSCM	PART NUMBER	DESCRIPTION USABLE ON CODE	U/M	QTY INC IN UNIT
18	1	PAFZZ	5935-00-823-0487	81349	UG88EU	GROUP 1801 CABLE ASSEMBLY (COAX) CONNECTOR, PLUG, ELEC.....	EA	4
18	2	MFFZZ						
					97			

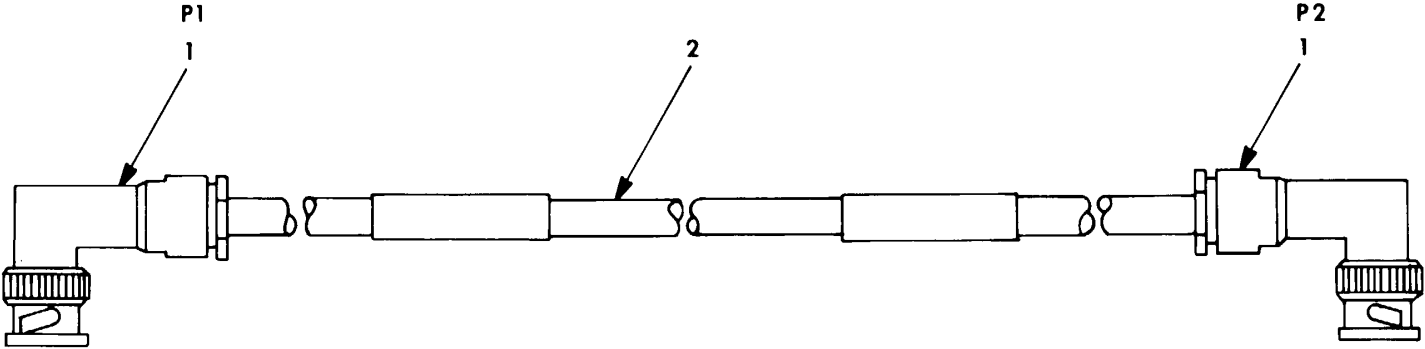

ITEM NO.	FROM	TO	WIRE COLOR	AWG NO.	WIRE LG. INCHES
2	A4A1W1P1	A4A1W1P2	COAX CABLE	RG58	108
2	A5A1W1P1	A5A1W1P2	COAX CABLE	RG58	108
2	A6A1W1P1	A6A1W1P2	COAX CABLE	RG58	240

EL8SA064

Figure 19. Cable Assembly (Coax) (FM-1, FM-2, FM-3).

SECTION II

TM 11-5821-285-30P

(1) ILLUSTRATION		(2)	(3)	(4)	(5)	(6)	(7)	(8)
(a) FIG NO.	(b) ITEM NO.	SMR CODE	NATIONAL STOCK NUMBER	FSCM	PART NUMBER	DESCRIPTION USABLE ON CODE	U/M	QTY INC IN UNIT
19	1	PAFZZ	5935-00-835-9148	80058	UG913BU	GROUP 1803 CABLE ASSEMBLY (COAX) (FM-1, F-2, FM-3)	EA	2
19	2	MFFZZ		80063	SC-D-972784-1	CONNECTOR, PLUG, ELEC CABLE, RADIO FREQUEN MAKE FROM 6145-00-542-6092		
					99/(100 blank)			

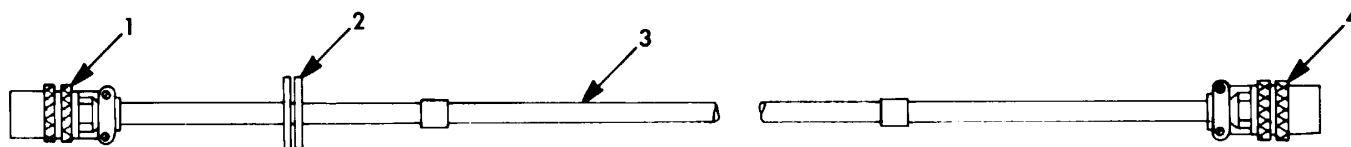

ITEM NO.	FROM	TO	WIRE COLOR	AWG NO.	WIRE LG. INCHES
3	MS3476F12-10P-H	MS3476F12-10S-H	WHT	22	108
3	MS3476F12-10P-J	MS3476F12-10S-J	RED	22	108
3	MS3476F12-10P-G	MS3476F12-10S-G	GRN	22	108
3	MS3476F12-10P-F	MS3476F12-10S-F	BLU/BLK	22	108
3	MS3476F12-10P-E	MS3476F12-10S-E	GRN/BLK	22	108
3	MS3476F12-10P-D	MS3476F12-10S-D	BLK/WHT	22	108
3	MS3476F12-10P-C	MS3476F12-10S-C	WHT/BLK	22	108
3	MS3476F12-10P-B	MS3476F12-10S-B	BLK	22	108
3	MS3476F12-10P-A	MS3476F12-10S-A	BLU	22	108

NOTE: FM-1, FM-2.

EL8SA065

Figure 20. Control Coupler Cable FM-1, FM-2, FM-3 (Sheet 1 of 2).

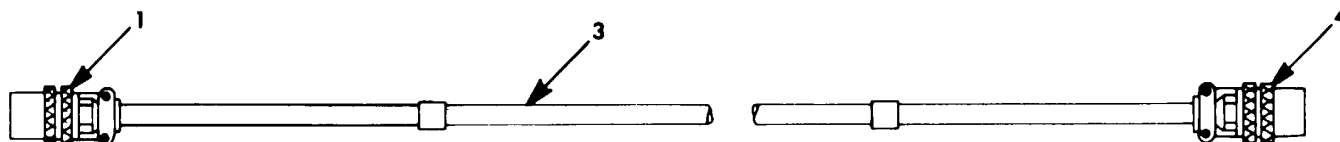

ITEM NO.	FROM	TO	WIRE COLOR	AWG NO.	WIRE LG. INCHES
3	MS3476F12-10P-H	MS3476F12-10S-H	WHT	22	240
3	MS3476F12-10P-J	MS3476F12-10S-J	RED	22	240
3	MS3476F12-10P-G	MS3476F12-10S-G	GRN	22	240
3	MS3476F12-10P-F	MS3476F12-10S-F	BLU/BLK	22	240
3	MS3476F12-10P-E	MS3476F12-10S-E	GRN/BLK	22	240
3	MS3476F12-10P-D	MS3476F12-10S-D	BLK/WHT	22	240
3	MS3476F12-10P-C	MS3476F12-10S-C	WHT/BLK	22	240
3	MS3476F12-10P-B	MS3476F12-10S-B	BLK	22	240
3	MS3476F12-10P-A	MS3476F12-10S-A	BLU	22	240

NOTE: FM-3

EL8SA066

Figure 20. Control Coupler Cable FM-1, FM-2, FM-3 (Sheet 2 of 2).

SECTION II

TM 11-5821-285-30P

(1) ILLUSTRATION		(2)	(3)	(4)	(5)	(6)	(7)	(8)
(a) FIG NO.	(b) ITEM NO.	SMR CODE	NATIONAL STOCK NUMBER	FSCM	PART NUMBER	DESCRIPTION USABLE ON CODE	U/M	QTY INC IN UNIT
						GROUP 1804 CONTROL COUPLER CABLE (FM-1, FM-2, FM-3)		
20	1	PAFZZ	5325-00-276-6090	96906	MS3476F12-10P	CONNECTOR PLUG	EA	3
20	2	PAFZZ		96906	MS35489-18	GROMMET, NONMETALLIC	EA	2
20	3	MFFZZ		81349	C012L0F12-22-0	CABLE, SPECIAL PURPO MAKE FROM 6145-00-889-0580		FTV
20	4	PAFZZ		96906	325 MS3476F12-1025	CONNECTOR PLUG	EA	3
					103			

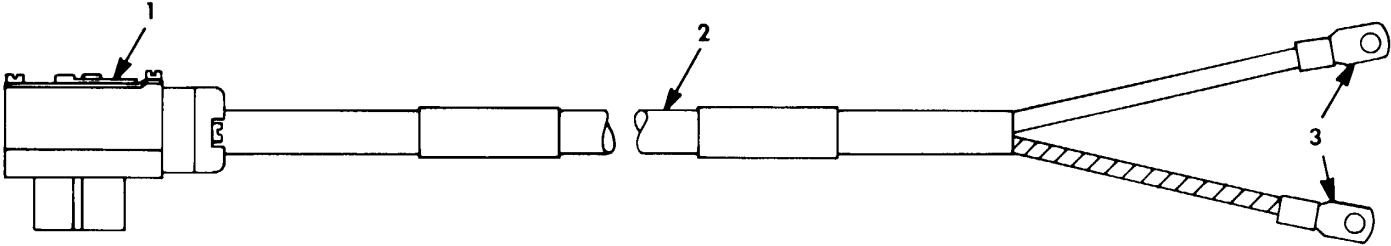

ITEM NO.	FROM	TO	WIRE COLOR	AWG NO.	WIRE LG. INCHES
2	164-201-1S17	LUG	BARE	8	174
2	164-201-1S17	LUG	WHT	8	180

EL85A067

Figure 21. Power Cable Assembly.

SECTION II

TM 11-5821-285-30P

(1) ILLUSTRATION		(2)	(3)	(4)	(5)	(6)	(7)	(8)
(a) FIG NO.	(b) ITEM NO.	SMR CODE	NATIONAL STOCK NUMBER	FSCM	PART NUMBER	DESCRIPTION USABLE ON CODE	U/M	QTY INC IN UNIT
21	1	PAFZZ	5935-00-964-4155	02660	164-201-1S17	GROUP 1805 POWER CABLE ASSEMBLY CONNECTOR, PLUG, ELEC.....	EA	1
21	2	MFFZZ		80063	SC-D-972780-1	CABLE, POWER, ELECTRI MAKE FROM 81349 C002HGF2 -8-0810	FT	V
21	3	PAFZZ	5940-00-113-9825	96906	MS20659-141	TERMINAL, LUG	EA	2
					105			

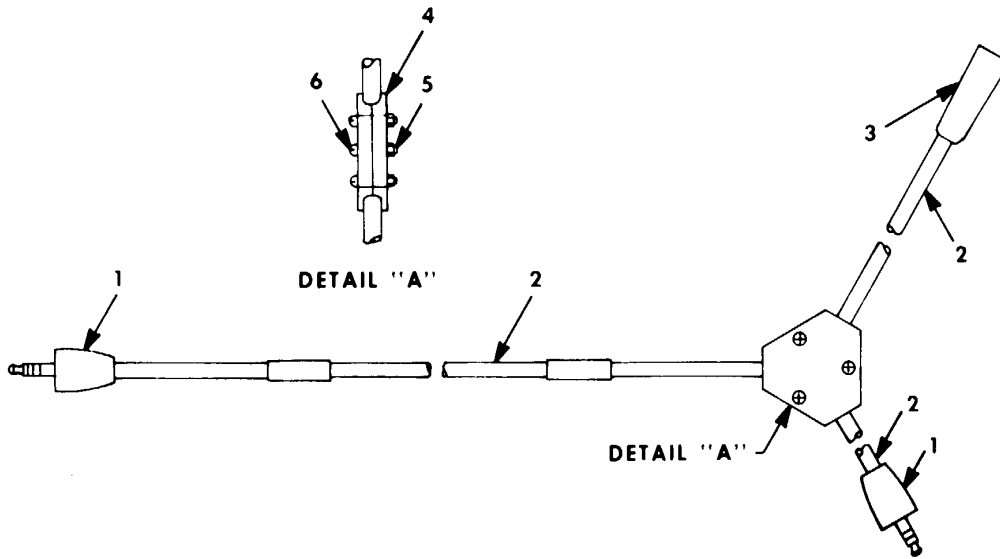

ITEM NO.	FROM	TO	WIRE COLOR	AWG NO.	WIRE LG. INCHES
2	U-93A/U-1	Y JUNCTION	GRN	24	48
2	U-93A/U-2	Y JUNCTION	WHT	24	48
2	U-93A/U-3	Y JUNCTION	RED	24	48
2	U-93A/U-4	Y JUNCTION	BLK	24	48
2	U-92A/U-1	Y JUNCTION	GRN	24	30
2	U-92A/U-2	Y JUNCTION	WHT	24	30
2	U-92A/U-3	Y JUNCTION	RED	24	30
2	U-92A/U-4	Y JUNCTION	BLK	24	30
2	U-93A/U-1	Y JUNCTION	GRN	24	6
2	U-93A/U-2	Y JUNCTION	WHT	24	6
2	U-93A/U-3	Y JUNCTION	RED	24	6
2	U-93A/U-4	Y JUNCTION	BLK	24	6

EL8SA068

Figure 22. "Y" Cable Assembly (Console to UH-1D Intercom).

SECTION II

TM 11-5821-285-30P

(1) ILLUSTRATION		(2)	(3)	(4)	(5)	(6)	(7)	(8)
(a) FIG NO.	(b) ITEM NO.	SMR CODE	NATIONAL STOCK NUMBER	FSCM	PART NUMBER	DESCRIPTION USABLE ON CODE	U/M	QTY INC IN UNIT
						GROUP 1806 "Y" CABLE ASSEMBLY (CONSOLE TO UH-ID INTERCOM)		
22	1	PAFZZ	5935-00-642-0626	81349	M9177/1-1	PLUG, TELEPHONE	EA	2
22	2	MFFZZ		80663	SC-D-972782-5	CABLE, SPECIAL PURPO MAKE FROM 6145-00-635-1536		FTV
22	3	PAFZZ	5935-00-665-5125	81349	M9177/3-1	JACK, TELEPHONE	EA	1
22	4	PAFZZ		80063	SC-C-972783	JUNCTION.....	EA	1
22	5	PAFZZ	5310-00-811-6419	96906	MS21042-04	NUT, SELF-LOCKING, EX.....	EA	3
22	6	PAFZZ	5305-00-958-0656	96906	MS35207-218	SCREW, MACHINE	EA	3
					107			

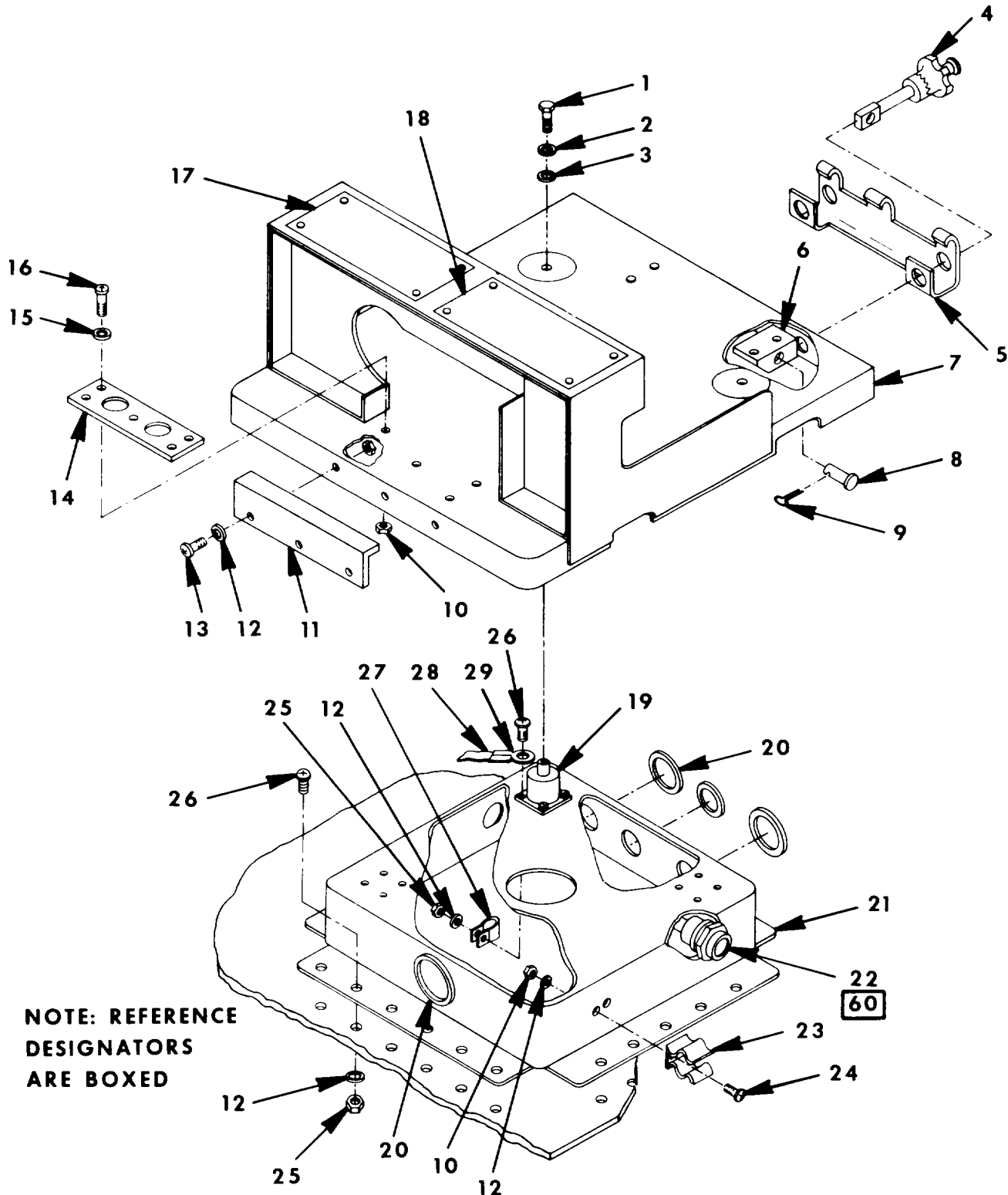

EL85A069

Figure 23. Repeater Mount Assembly and Repeater Shock Mount Assembly.

SECTION II

TM 11-5821-285-30P

(1) ILLUSTRATION		(2)	(3)	(4)	(5)	(6)	(7)	(8)
(a) FIG NO.	(b) ITEM NO.	SMR CODE	NATIONAL STOCK NUMBER	FSCM	PART NUMBER	DESCRIPTION USABLE ON CODE	U/M	QTY INC IN UNIT
						GROUP 19 REPEATER MOUNT ASSEMBLY		
						GROUP 22 REPEATER SHOCK MOUNT ASSEMBLY		
23	1	PAFZZ	5306-00-584-6863	88044	AN101306	BOILT, MACHNE	EA	4
23	2	PAFZZ	5310-00-550-5009	96906	MS15795-704	WASHER, FLAT	EA	4
23	3	PAFZZ		96906	MS95904-69	WASHER, LOCK	EA	4
23	4	PAFZZ	5340-01-057-1227	96906	MS14108-2	BOLT ASSEMBLY, CLAMP	EA	2
23	5	XBFZZ		80063	SC-D-972664	CLAMP	EA	1
23	6	XBFZZ		80063	SC-C-972665	BRACKET CHANNEL	EA	2
23	7	XBFZZ		80063	SC-D-972654	BASE	EA	1
23	8	PAFZZ		96906	MS203922C1T	PIN STD HEAD	EA	2
23	9	PAFZZ	5315-01-027-6616	96906	MS24665-132	PIN, COTTER	EA	2
23	10	PAFPZ	5310-00-245-3495	96906	MS17828-06C	NUT SELF-LOCKING	EA	4
23	11	XBFZZ		80063	SC-C-972659	STOP	EA	1
23	12	PAFZZ	5310-00-809-8546	96906	MS27183-8	WASHER, FLAT	EA	27
23	1	PAFZZ	5305-00-989-6265	96906	MS35207-262	SCREW, MACHINE	EA	3
23	14	MFFZZ		80063	SC-C-972660	PAD	EA	1
23	1	PAFZZ	531D-00-983-8483	96906	MS27183-5	WASHER, FLAT	EA	5
23	16	PAFZZ	5305-00-059-4552	96906	MS35190-237	SCREW, MACHINE	EA	5
23	17	XBFZZ		80063	SC-C-972663	PLATE IDENT	EA	1
23	18	XBFZZ		80063	SC-C-972662	PLATE IDENT	EA	1
23	19	PAFZZ	5340-00-741-1785	81860	844DB4	MOUNT	EA	4
23	20	PAFZZ	5325-00-017-3301	96906	MS21266-2N	GROMMET, NONMETALLIC	FT	V
23	21	XBFZZ		80063	SC-D-972649	BASE SHOCK MOUNT	EA	1
23	22	AFFFF		80063	SC-C-972650	CABLE ASSY SEE FIGURE 24 FOR PARTS	EA	1
23	23	PAFZZ		81349	M20466/2-036	CLIP SPRING TENSION	EA	2
23	24	PAFZZ	5305-00-984-4988	96906	MS35206-25	SCREW, MACHINE	EA	4
23	25	PAFZZ	5310-01-006-2084	96906	MS17828-3F	NUT, SELF-LOCKING, HE	EA	22
23	26	PAFZZ	5305-00-989-7435	96906	MS35207-264	SCREW, MACHINE	EA	22
23	27	PAFZZ	5340-00-205-6301	96906	MS21919DG-4	CLAMP, LOOP	EA	2
23	28	XAFZZ		81349	QQ8875R34T131	WIRE BRAID	FT	V
23	29	XAFZZ		96906	MS25036-156	TERNINAL, LUG	EA	1

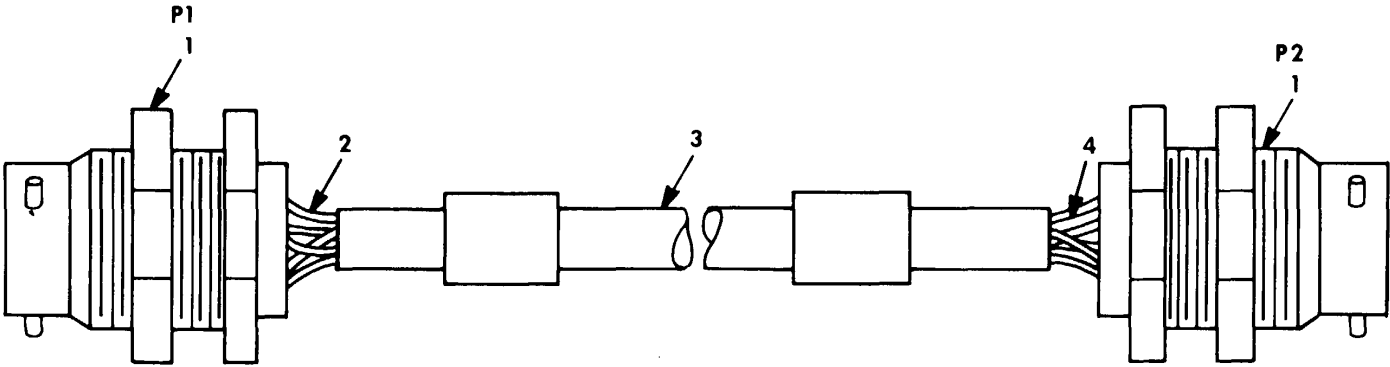

ITEM NO.	FROM	TO	WIRE COLOR	AWG NO.	WIRE LG. INCHES
2	P1-A	P2-A	SHD	20	14
4	P1-C	P2-K	WHT	20	14
2	P1-D	P2-F	SHD	20	14
2	P1-F	P2-D	SHD	20	14
4	P1-K	P2-C	WHT	20	14

EL8SA070

Figure 24. Cable Assembly (Repeater Shockmount).

SECTION II

TM 11-5821-285-30P

(1) ILLUSTRATION		(2)	(3)	(4)	(5)	(6)	(7)	(8)
(a) FIG NO.	(b) ITEM NO.	SMR CODE	NATIONAL STOCK NUMBER	FSCM	PART NUMBER	DESCRIPTION USABLE ON CODE	U/M	QTY INC IN UNIT
24	1	PAFZZ	5935-00-912-8163	96906	MS3124E16-26S	GROUP 2201 CABLE ASSEMBLY (REPEATER SHOCKMOUNT)	EA	2
24	2	MFFZZ		80063	SC-C-972650-5	CONNECTOR, RECEPTAC.....	FT	V
24	3	MFFZZ		80063	SC-D-972650-9	CABLE SPECIAL PRP MAKE FROM 81349 MWC20-7JS9	FT	V
24	4	MFFZZ		80063	SC-D-972650-4	INSULATION SLEEVE MAKE FROM 80063 SC-C-681323-9 WIRE, ELECTRICAL MAKE FROM 81349 MWC20-7J9	FT	V
					111			

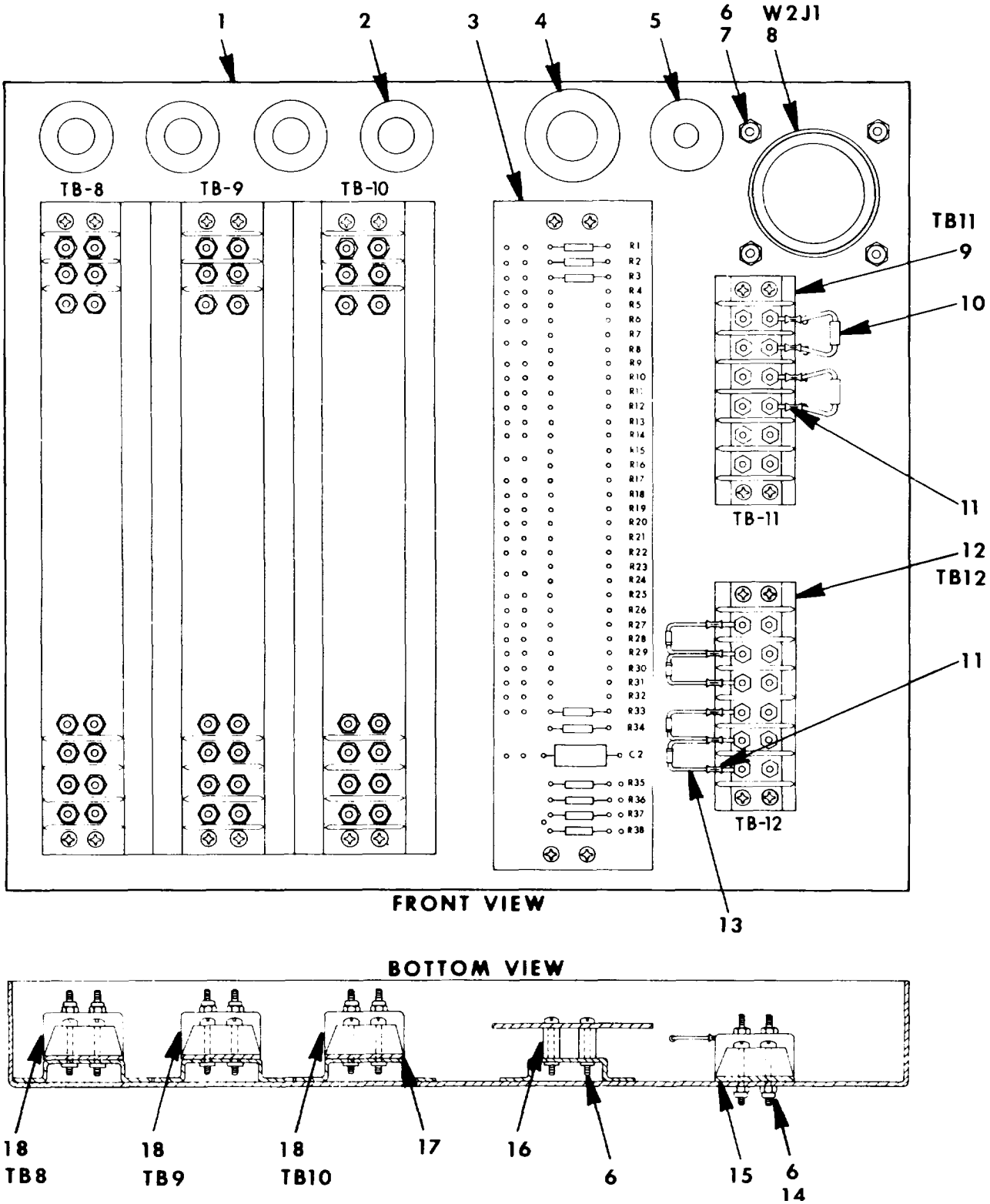

Figure 25. Radio Junction Box Assembly.

SECTION II

TM 11-5821-285-30P

(1) ILLUSTRATION		(2)	(3)	(4)	(5)	(6) DESCRIPTION	(7)	(8)
(a) FIG NO.	(b) ITEM NO.	SMR CODE	NATIONAL STOCK NUMBER	FSCM	PART NUMBER	USABLE ON CODE	U/M	QTY INC IN UNIT
						GROUP 24 RADIO JUNCTION BOX ASSEMBLY		
25	1	XBFZZ		80063	SC-D-972600	BOX WELD ASSEMBLY	EA	1
25	2	PAFZZ	5325-00-276-6100	88044	AN931-8-13	GROMMET, NONMETALLIC	EA	4
25	3	XBFFF		80063	SC-C-972608	AUDIO PAD ASSEMBLY	EA	1
25	4	PAFZZ	5325-00-276-6091	88044	AN931-11-16	GROMMET, NONMETALLIC	EA	1
25	5	PAFZZ	5325-00-174-5315	96906	MS35489-7	GROMMET, NONMETALLIC	EA	1
25	6	PAFZZ	5310-00-081-808T	96906	MS21044N06	NUT, SELF-LOCKING, HE	EA	4
25	7	PAFZZ	5305-00-889-3000	96906	MS35206-230	SCREW, MACHINE	EA	4
25	8	PAFZZ	5935-00-952-7408	96906	MS3102R28-16S	CONNECTOR, RECEPTACL	EA	1
25	9	PAFZZ		80063	SC-C-972604	TERMINAL BLOCK ASSY	EA	1
25	10	XAFZZ		81349	RCR20G102JS	RESISTOR, FIXED, COMP	EA	2
25	11	XAFZZ		96906	MS25036-103	TERMINAL, LUG	EA	6
25	12	PAFZZ		80063	SC-C-972634	TERMINAL BLOCK ASSY	EA	1
25	13	XAFZZ		81349	JAN-1N645	SEMICONDUCTOR DEVIC	EA	4
25	14	XAFZZ		96906	MS35206-25	SCREW, MACHINE	EA	4
25	15	XBFZZ		80063	SC-D-972632	SPACER TERM STRIP	EA	2
25	16	XBFZZ		83330	8502	SPACER, SLEEVE	EA	4
25	17	XBFZZ		80063	SC-B-972603	SPACER TERM STRIP	EA	3
25	18	PAFZZ		80063	SC-B-972607	TERMINAL BLOCK ASSY	EA	3

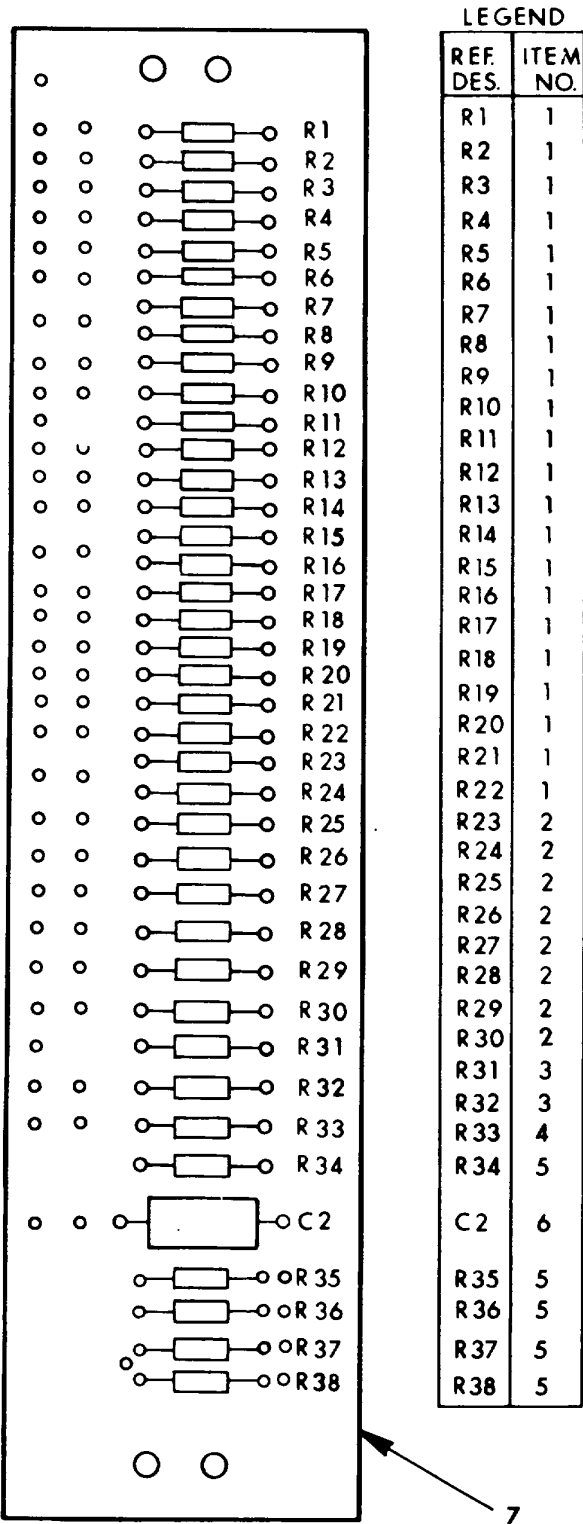

Figure 26. Audio Pad Assembly.

EL8SA072

SECTION II

TM 11-5821-285-30P

(1) ILLUSTRATION		(2)	(3)	(4)	(5)	(6)	(7)	(8)
(a) FIG NO.	(b) ITEM NO.	SMR CODE	NATIONAL STOCK NUMBER	FSCM	PART NUMBER	DESCRIPTION USABLE ON CODE	U/M	QTY INC IN UNIT
						GROUP 2401 AUDIO PAD ASSEMBLY		
26	1	PAFZZ	5905-00-106-9344	81349	RCR20G101JS	RESISTOR, FIXED, COMP	EA	22
26	2	PAFZZ	5905-00-114-5361	81349	RCR20G121JS	RESISTOR, FIXED, COMP	EA	8
26	3	PAFZZ	5905-00-108-6922	81349	RCR20G151JS	RESISTOR, FIXED, COP	EA	2
26	4	PAFZZ	5905-00-114-5399	81349	RCR20G241JS	RESISTOR, FIXED, CO'P	EA	1
26	5	PAFZZ	5905-00-114-5407	81349	RCR20G271JS	RESISTOR, FIXED, COP	EA	5
26	6	PAFZZ	5910-00-010-6538	81349	M39006-09-6572	CAPACITOR, FIXED, ELE	EA	1
26	7	XAFZZ		80063	SC-D-972609	AUDIO PAD	EA	1
115								

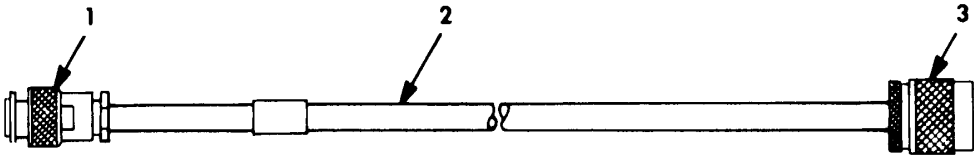

ITEM NO.	FROM	TO	WIRE COLOR	AWG NO.	WIRE LG. INCHES
2	UG-88/U	UG-536 B/U	COAX CABLE	RG58	26

EL8SA073

Figure 27. AN/ARC-51 Coax Cable.

SECTION II

TM 11-5821-285-30P

(1) ILLUSTRATION		(2)	(3)	(4)	(5)	(6)	(7)	(8)
(a) FIG NO.	(b) ITEM NO.	SMR CODE	NATIONAL STOCK NUMBER	FSCM	PART NUMBER	DESCRIPTION USABLE ON CODE	U/M	QTY INC IN UNIT
						GROUP 25 AN/ARC-51 COAX CABLE		
27	1	PAFZZ	5935-01-043-0629	81349	M39012/16-0101	CONNECTOR, PLUG, ELEC..... EZ4	EA	1
27	2	MFFZZ		80058	RG58U	CABLE RF MAKE FROM 80058 RG58U EZ4	FT	V
27	3	PAFZZ	5935-00-660-4296	80058	UG-536C/U	CONNECTOR, PLUG, ELEC..... EZ4	EA	1
117								

SECTION II

TM 11-5821-285-30P

(1) ILLUSTRATION		(2)	(3)	(4)	(5)	(6)	(7)	(8)
(a) FIG NO.	(b) ITEM NO.	SMR CODE	NATIONAL STOCK NUMBER	FSCM	PART NUMBER	DESCRIPTION USABLE ON CODE	U/M	QTY INC IN UNIT
GROUP 99 BULK MATERIALS								
BULK		PAFZZ		81349	MILW16878-4BGES9	CABLE SPECIAL PRP	FT	
BULK		PAFZZ		81349	MILW16878-4BGE9	WIRE ELEC 20 AWG	FT	
BULK		PAFZZ		81349	MILW16878-4BJE9	WIRE ELEC 16 AWG	FT	
BULK		PAFZZ		81349	MWC-20-7J9058	WIRE ELEC 20 AWG	FT	
BULK		PAFZZ		81349	MWC18-7J0	WIRE ELEC 18 AWG	FT	
BULK		PAFPZ		81349	MWC18-7J2	WIRE ELEC 18 AWG	FT	
BULK		PAFZZ		81349	MWC18-7J9	WIRE ELEC 18 AWG	FT	
BULK		PAFZZ	6145-00-635-3534	81349	MWC20-7JSJ9	CABLE, SPECIAL PURPO	FT	
BULK		PAFZZ	6145-00-160-5318	81349	MWC20-7J0	WIRE, ELECTRICAL	FT	
BULK		PAFZZ	6145-00-643-1294	81349	MWC20-7J9	WIRE, ELECTRICAL	FT	
BULK		PAFZZ		81349	MWC20-7J9012	WIRE ELEC 20 AWG.	FT	
BULK		PAFZZ		81349	MWC20-7J9013	WIRE ELEC 20 AWG	FT	
BULK		PAFZZ		81349	MWC20-7J9014	WIRE ELEC 20 AWG	FT	
BULK		PAFZZ		81349	MWC20-7J9015	WIRE ELEC 20 AWG	FT	
BULK		PAFZZ		81349	MWC20-7J9016	WIRE ELEC 20 AWG	FT	
BULK		PAFZZ		81349	MWC20-7J9017	WIRE ELEC 20 AWG	FT	
BULK		PAFZZ		81349	MWC20-7J9018	WIRE ELEC 20 AWG	FT	
BULK		PAFZZ		81349	MWC20-7J9023	WIRE ELEC 20 AWG	FT	
BULK		PAFZZ		81349	MWC20-7J9024	WIRE ELEC 20 AWG	FT	
BULK		PAFZZ		81349	MWC20-7J9025	WIRE FLEC 20 AWG	FT	
BULK		PAFZZ		81349	MWC20-7J9026	WIRE ELEC 20 AWG	FT	
BULK		PAFZZ		81349	MWC20-7J9027	WIRE ELEC 20 AWG	FT	
BULK		PAFZZ		81349	MWC20-7J9028	WIRE ELEC 20 AWG	FT	
BULK		PAFZZ		81349	MWC20-7J9034	WIRE ELEC 20 AWG	FT	
BULK		PAFZZ		81349	MWC20-7J9035	WIRE ELEC 20 AWG	FT	
BULK		PAFZZ		81349	MWC20-7J9036	WIRE ELEC 20 AWG	FT	
BULK		PAFZZ		81349	MWC20-7J9037	WIRE ELEC 20 AWG	FT	
BULK		PAFZZ		81349	MWC20-7J9038	WIRE ELEC 20 AWG	FT	
BULK		PAFZZ		81349	MWC20-7J904	WIRE ELEC 20 AWG	FT	
BULK		PAFZZ		81349	MWC20-7J9045	WIRE ELEC 20 AWG	FT	
BULK		PAFZZ		81349	MWC20-7J9046	WIRE ELEC 20 AWG	FT	
BULK		PAFZZ		81349	MWC20-7J9047	WIRE ELEC 20 AWG	FT	
BULK		PAFZZ		81349	MWC20-7J9048	WIRE ELEC 20 AWG	FT	
BULK		PAFZZ		81349	MWC20-7J905	WIRE ELEC 20 AWG	FT	
BULK		PAFZZ		81349	MWC20-7J9056	WIRE ELEC 20 AWG	FT	
BULK		PAFZZ	6145-00-226-8869	81349	MWC20-7J9057	WIRE ELEC 20 AWG	FT	
BULK		PAFZZ		81349	MWC20-7J906	WIRE, ELECTRICAL	FT	
BULK		PAFZZ		81349	MWC20-7J9067	WIRE ELEC 20 AWG	FT	
BULK		PAFZZ		81349	MWC20-7J9068	WIRE ELEC 20 AWG	FT	

SECTION II

TM 11-5821-285-30P

(1) ILLUSTRATION		(2)	(3)	(4)	(5)	(6)	(7)	(8)
(a) FIG NO.	(b) ITEM NO.	SMR CODE	NATIONAL STOCK NUMBER	FSCM	PART NUMBER	DESCRIPTION USABLE ON CODE	U/M	QTY INC IN UNIT
BULK		PAFZZ		81349	MWC20-7J907	WIRE ELEC 20 AWG	FT	
BULK		PAFZZ		81349	MWC20-7J9078	WIRE ELEC 20 AWG	FT	
BULK		PAFPZ		81349	MWC20-7J908	WIRE ELEC 20 AWG	FT	
BULK		PAFPZ	6145-00-548-2402	81349	MWC20-7J912	WIRE, ELECTRICAL	FT	
BULK		PAFZZ		81349	MWC20-7J9123	WIRE ELEC 20 AWG	FT	
BULK		PAFZZ		81349	MWC20-7J9124	WIRE ELEC 20 AWG	FT	
BULK		PAFZZ		81349	MWC20-7J925	WIRE ELEC 20 AWG	FT	
BULK		PAFZZ		81349	MWC20-7J9126	WIRE ELEC 20 AWG	FT	
BULK		PAFZZ		81349	MWC20-7J9127	WIRE ELEC 20 AWG	FT	
BULK		PAFZZ		81349	MWC20-7J9128	WIRE ELEC 20 AWG	FT	
BULK		PAFZZ	6145-00-548-0974	81349	MWC20-7J913	WIRE, ELECTRICAL	FT	
BULK		PAFZZ		81349	MWC20-7J9134	WIRE ELEC 20 AWG	FT	
BULK		PAFZZ		81349	MWC20-7J9135	WIRE ELEC 20 AWG	FT	
BULK		PAFZZ		81349	MWC20-7J9136	WIRE ELEC 20 AWG	FT	
BULK		PAFZZ		81349	MWC20-7J9137	WIRE ELEC 20 AWG	FT	
BULK		PAFZZ		81349	MWC20-7J9138	WIRE ELEC 20 AWG	FT	
BULK		PAFZZ		81349	MWC20-7J914	WIRE ELEC 20 AWG	FT	
BULK		PAFZZ		81349	MWC20-7J9145	WIRE ELEC 20 AWG	FT	
BULK		PAFZZ		81349	MWC20-7J9146	WIRE ELEC 20 AWG	FT	
BULK		PAFZZ		81349	MWC20-TJ9147	WIRE ELEC 20 AWG	FT	
BULK		PAFZZ		81349	MWC20-TJ148	WIRE ELEC 20 AWG	FT	
BULK		PAFZZ		81349	MWC20-7J915	WIRE ELEC 20 AWG	FT	
BULK		PAFZZ		81349	MWC20-7J9156	WIRE ELEC 20 AWG	FT	
BULK		PAFZZ		81349	MWC20-7J9157	WIRE ELEC 20 AWG	FT	
BULK		PAFZZ		81349	MWC20-7J9158	WIRE ELEC 20 AWG	FT	
BULK		PAFZZ		81349	MWC20-7J916	WIRE ELEC 20 AWG	FT	
BULK		PAFZZ		81349	MWC20-7J9167	WIRE ELEC 20 AWG	FT	
BULK		PAFZZ		81349	MWC20-7J9168	WIRE ELEC 20 AWG	FT	
BULK		PAFZZ		81349	MWC20-7J917	WIRE ELEC 20 AWG	FT	
BULK		PAFZZ		81349	MWC20-7J9178	WIRE ELEC 20 AWG	FT	
BULK		PAFZZ		81349	MWC20-7J918	WIRE ELEC 20 AWG	FT	
BULK		PAFZZ		81349	MWC20-7J923	WIRE ELEC 20 AWG	FT	
BULK		PAFZZ		81349	MWC20-7J9234	WIRE ELEC 20 AWG	FT	
BULK		PAFZZ		81349	MWC20-7J9235	WIRE ELEC 20 AWG	FT	
BULK		PAFZZ		81349	MWC20-7J9236	WIRE ELEC 20 AWG	FT	
BULK		PAFZZ		81349	MWC20-7J9237	WIRE ELEC 20 AWG	FT	
BULK		PAFZZ		81349	MWC20-7J9238	WIRE ELEC 20 AWG	FT	
BULK		PAFZZ	6145-00-643-4684	81349	MWC20-7J924	WIRE, ELECTRICAL	FT	
BULK		PAFZZ		81349	MWC20-7J9245	WIRE ELEC 20 AWG	FT	
BULK		PAFZZ		81349	MWC20-7J9247	WIRE ELEC 20 AWG	FT	

SECTION II

TM 11-5821-285-30P

(1) ILLUSTRATION		(2)	(3)	(4)	(5)	(6)	(7)	(8)
(a) FIG NO.	(b) ITEM NO.	SMR CODE	NATIONAL STOCK NUMBER	FSCM	PART NUMBER	DESCRIPTION USABLE ON CODE	U/M	QTY INC IN UNIT
BULK		PAFZZ		81349	MWC20-7J9248	WIRE ELEC 20 AWG	FT	
BULK		PAFZZ	6145-00-500-4783	81349	MWC20-7J925	WIRE, ELECTRICAL	FT	
BULK		PAFZZ		81349	MWC20-7J9256	WIRE ELEC 20 AWG	FT	
BULK		PAFZZ		81349	MWC20-7J9257	WIRE ELEC 20 AWG	FT	
BULK		PAFZZ		81349	MWC20-7J9258	WIRE ELEC 20 AWG	FT	
BULK		PAFZZ	6145-00-669-6570	81349	MWC20-7J926	WIRE, ELECTRICAL	FT	
BULK		PAFZZ		81349	MWC20-7J9267	WIRE ELEC 20 AWG	FT	
BULK		PAFZZ		81349	MWC20-7J9268	WIPE ELEC 20 AWG	FT	
BULK		PAFZZ		81349	MWC20-7J927	WIRE ELEC 20 AWG	FT	
BULK		PAFZZ		81349	MWC20-7J9278	WIRE ELEC 20 AWG	FT	
BULK		PRAFZ		81349	MWC20-7J928	WIRE ELEC 20 AWG	FT	
BULK		PAFZZ		81349	MWC20-7J934	WIRE ELEC 20 AWG	FT	
BULK		PAFZZ		81349	MWC20-7J9345	WIRE ELEC 20 AWG	FT	
BULK		PAFZZ		81349	MWC20-7J9346	WIRE ELEC 20 AWG	FT	
BULK		PAFZZ		81349	MWC20-7J9347	WIRE ELEC 20 AWG	FT	
BULK		PAFZZ	6145-00-504-1149	81349	MWC20-7J935	WIRE, ELECTRICAL	FT	
BULK		PAF7Z	6145-00-669-6769	81349	MWC20-7J936	WIRE, ELECTRICAL	FT	
BULK		PAFZZ		81349	MWC20-7J937	WIRE ELEC 20 AWG	FT	
BULK		PAFZZ		81349	MWC20-7J938	WIRE ELEC 20 AWG	FT	
BULK		PAFZZ		81349	MWC20-7J945	WIRE ELEC 20 AWG	FT	
BULK		PAFZZ	6145-00-669-6768	81349	MWC20-7J946	WIRE, ELECTRICAL	FT	
BULK		PAFZZ		81349	MWC20-7J947	WIRE ELEC 20 AWG	FT	
BULK		PAFZZ		81349	MWC20-7J948	WIRE ELEC 20 AWG	FT	
BULK		PAFZZ	6145-00-669-6764	81349	MWC20-7J956	WIRE, ELECTRICAL	FT	
BULK		PAFZZ		81349	MWC20-7J957	WIRE ELEC 20 AWG	FT	
BULK		PAFZZ		81349	MWC20-7J958	WIRE ELEC 20 AWG	FT	
BULK		PAFZZ		81349	MWC20-7J967	WIRE ELEC 20 AWG	FT	
BULK		PAFZZ		81349	MWC20-7J968	WIRE ELEC 20 AWG	FT	
BULK		PAFZZ		81349	MWC20-7J978	WIRE ELEC 20 AWG	FT	
BULK		PAFZZ	5970-00-945-2849	81349	M23053/2-105-0	INSULATION SLEEVING	FT	
BULK		PAFZZ	5970-00-942-7612	81349	M23053/2-106-0	INSULATION SLEEVING	FT	
BULK		PAFZZ	5970-00-939-8941	81349	M23053/2-107-0	INSULATION SLEEVING	FT	
BULK		PAFZZ	5970-00-948-6660	81349	M23053/2-108-0	INSULATION SLEEVING	FT	
BULK		PAFZZ	5970-00-939-8942	81349	M23053/2-109-0	INSULATION SLEEVING	FT	
BULK		PAFZZ	5970-00-812-2974	81349	M23053/5-103-0	INSULATION SLEEVING	FT	
BULK		PAFZZ	5970-00-812-2969	81349	M23053/5-104-0	INSULATION SLEEVING	FT	
BULK		PAFZZ	5970-00-954-1622	81349	M23053/5-105-0	INSULATION SLEEVING	FT	
BULK		PAFZZ	5970-00-954-1624	81349	M23053/5-107-0	INSULATION SLEEVING	FT	
BULK		PAFZZ	6145-00-578-7517	81349	M5086/1-16-9	WIRE, ELECTRICAL	FT	
BULK		PAFZZ		81349	M5086/1-18-1	WIRE ELEC 18 AWG	FT	

SECTION II

TM 11-5821-285-30P

(1) ILLUSTRATION		(2)	(3)	(4)	(5)	(6)	(7)	(8)
(a) FIG NO.	(b) ITEM NO.	SMR CODE	NATIONAL STOCK NUMBER	FSCM	PART NUMBER	DESCRIPTION USABLE ON CODE	U/M	QTY INC IN UNIT
BULK		PAFZZ		81349	M5086/1-18-2	WIRE ELEC 18 AWG EZ3	FT	
BULK		PAFZZ		81349	M5086/1-18-3	WIRE ELEC 18 AWG	FT	
BULK		PAFZZ		81349	M5086/1-18-4	WIRE ELEC 18 AWG	FT	
BULK		PAFZZ		81349	M5086/1-18-0	WIRE ELEC 18 AWG	FT	
BULK		PAFZZ	6145-00-578-7519	81349	M5086/1-20-9	WIRE, ELECTRICAL	FT	
BULK		PAFZZ		81349	M5086/1-20-90	WIRE ELEC 20 AWG	FT	
BULK		PAFZZ		81349	M5086/1-20-901	WIRE ELEC 20 AWG	FT	
BULK		PAFZZ		81349	M5086/1-20-902	WIRE ELEC 20 AWG	FT	
BULK		PAFZZ		81349	M5086/1-20-903	WIRE ELEC 20 AWG	FT	
BULK		PAFZZ		81349	M5086/1-20-91	WIRE ELEC 20 AWG	FT	
BULK		PAFZZ		81349	M5086/1-20-92	WIRE ELEC 20 AWG	FT	
BULK		PAFZZ		81349	M5086/1-20-93	WIRE ELEC 20 AWG	FT	
BULK		PAFZZ		81349	M5086/1-20-94	WIRE ELEC 20 AWG	FT	
BULK		PAFZZ		81349	M5086/1-20-95	WIRE ELEC 20 AWG	FT	
BULK		PAFZZ		81349	M5086/1-20-96	WIRE ELEC 20 AWG	FT	
BULK		PAFZZ		81349	M5086/1-20-97	WIRE ELEC 20 AWG	FT	
BULK		PAFZZ		BL349	M5086/1-20-98	WIRE ELEC 70 AWG	FT	
BULK		PAFZZ	6145-00-191-330R	81349	M7078-2-20-1	CABLE, SPECIAL PURPO EZ3	FT	
BULK		PAFZZ		81348	QQB573R36T078	WIRE BRAID	FT	
BULK		PAFZZ		81349	QQB87R34T131	WIRE BRAID	FT	
BULK		PAFZZ	6145-00-54?-6092	99974	MM3424	CABLE, RADIO FREQUEN	FT	
BULK		PAFZZ	6L4S-00-542-6092	80058	RG58CU	CABLE, RADIO FREQUEN	FT	
BULK		PAFZZ	6145-00-635-1536	81349	WM85U	CABLE, SPECIAL PURPO	FT	
BULK		PAFZZ	5970-01-094-0479		ZTZ-0250-63-	INSULATION SLEEVING	FT	
				07240	20BLACK			
BULK		PAFZZ	5970-00-892-1020	92194	PVC105 1-2 BLACK	INSULATION SLEEVING	RL	
BULK		PAFZZ	S970-00-681-9774	24617	778578	INSULATION SLEEVING	RL	
BULK		PAFZZ	5970-00-892-0986	96214	411634-8800	INSULATION SLEEVING	RL	
BULK		MFFZZ			C012L0F12-22-03	CABLE, SPFCIAL PURPO	RL	
				81349	25			
BULK		PAFZZ	5970-00-892-0939	96214	411634-1000	INSULATION SLEEVING	RL	

SECTION IV

NATIONAL STOCK NUMBER AND PART NUMBER INDEX

TM 11-5821-285-30P

NOTE: LATEST NATIONAL STOCK NUMBER ASSIGNMENTS ARE INCLUDED AT END OF INDEX.

STOCK NUMBER	FIGURE. NO.	ITEM NO.	STOCK NUMBER	FIGURE. NO.	ITEM NO.
5910-00-010-6538	26	6	5310-00-559-0070	3	3
5310-00-045-3299	2	8	6145-00-578-7517	BULK	
5310-00-045-3299	3	5	6145-00-578-7519	BULK	
5310-00-045-3299	16	7	5306-00-584-6863	23	1
5310-00-045-3299	16	24	5340-00-598-0415	16	9
5310-00-045-3299	16	41	5365-00-598-5394	10	7
5310-00-045-4007	16	39	5930-00-615-7896	16	40
5310-00-058-1823	4	2	6145-00-635-1536	BULK	
5310-00-058-1823	16	32	6145-00-635-3534	BULK	
5305-00-059-4552	23	16	5310-00-637-9541	17	12
5305-00-059-4568	2	4	5310-00-638-9857	17	33
5305-00-059-4568	3	7	5935-00-642-0626	22	1
5310-00-060-2039	2	5	6145-00-643-1294	BULK	
5310-00-061-0004	16	14	6145-00-643-4684	BULK	
5310-00-066-5014	17	13	5935-00-660-4296	27	3
5325-00-074-3301	23	20	5340-00-664-4051	16	28
5310-00-081-8087	4	8	5935-00-665-5125	22	3
5310-00-081-8087	17	34	6145-00-669-6570	BULK	
5310-00-081-8087	25	6	6145-00-669-6764	BULK	
5821-00-082-3926	1	17	6145-00-669-6768	BULK	
5821-00-082-3927	1	19	6145-00-669-6769	BULK	
5821-00-082-3928	1	18	5970-00-681-9774	BULK	
5310-00-087-4652	17	17	5365-00-682-1427	10	3
5935-00-089-8052	8	9	5365-00-721-7554	10	10
5935-00-089-8052	9	8	5935-00-725-7723	10	9
5905-00-106-9344	26	1	5935-00-726-6519	10	16
5905-00-108-6922	6	9	5310-00-732-0560	17	11
5905-00-108-6922	11	9	5340-00-741-1785	23	19
5905-00-108-6922	26	3	5935-00-152-2979	6	1
5940-00-113-3138	7	5	5935-00-752-2979	11	1
5940-00-113-3138	8	11	5935-00-761-3885	10	8
5940-00-113-3138	9	10	5310-00-773-7618	17	16
5940-00-113-9825	21	3	5310-00-807-1466	3	16
5905-00-114-5361	26	2	5310-00-807-1466	16	10
5905-00-114-5399	26	4	5310-00-807-1466	16	17
5905-00-114-5407	26	5	5310-00-807-1468	16	23
5821-00-138-7990	1	14	5310-00-809-8546	2	7
5305-00-140-8001	16	51	5310-00-809-8546	3	4
5940-00-143-4771	11	4	5310-00-809-8546	23	12
5325-00-147-6442	17	30	5310-00-811-6419	22	5
5306-00-151-1426	17	21	5970-00-812-2969	BULK	
6145-00-160-5318	BULK		5970-00-812-2974	BULK	
5935-00-163-3644	11	7	5935-00-823-0487	18	1
5935-00-173-5048	11	6	5935-00-825-8864	6	8
5925-00-173-7155	16	8	5935-00-826-1020	8	14
5925-00-173-7158	16	16	5935-00-826-1020	9	13
5325-00-174-5315	25	5	5365-00-828-8526	10	6
6145-00-191-3308	BULK		5935-00-835-9148	19	1
5340-00-200-2729	16	19	5320-00-845-7751	14	8
5940-00-204-8966	6	3	5935-00-870-3632	5	3
5940-00-204-8966	12	2	5810-00-877-8391	1	2
5940-00-204-8966	13	2	5935-00-880-8890	3	28
5340-00-205-6301	23	27	5935-00-880-8890	15	3
5305-00-225-3850	16	27	5305-00-889-3000	4	14
6145-00-226-8869	BULK		5305-00-889-3000	25	7
5310-00-245-3495	23	10	5305-00-889-3118	3	26
6130-00-252-0004	16	36	5305-00-889-3118	16	33
5325-00-276-6090	20	2	5970-00-892-0939	BULK	
5325-00-276-6091	4	13	5970-00-892-0986	BULK	
5325-00-276-6091	25	4	5970-00-892-1020	BULK	
5325-00-276-6100	4	6	5935-00-892-9894	8	5
5325-00-276-6100	25	2	5935-00-892-9894	9	4
5935-00-280-2353	11	2	5935-00-902-2344	3	23
5340-00-286-9418	16	20	5935-00-902-2344	15	1
5935-00-480-6861	6	4	5935-00-904-5873	10	14
5340-00-490-2118	2	3	5935-00-912-8163	24	1
5340-00-490-2118	3	9	5810-00-919-4554	1	6
6145-00-500-4783	BULK		5821-00-926-7230	1	13
6145-00-504-1149	BULK		5831-00-933-9822	1	5
5310-00-531-9515	17	22	5310-00-934-9737	3	27
6210-00-538-8770	8	124	5935-00-936-8561	10	4
6210-00-538-8770	9	70	5821-00-937-4686	1	7
6145-00-542-6092	BULK		5821-00-937-9614	1	8
6145-00-542-6092	BULK		5915-00-937-9997	14	4
6145-00-548-0974	BULK		5970-00-939-8941	BULK	
6145-00-548-2402	BULK		5970-00-939-8942	BULK	
5310-00-550-5009	23	2	5970-00-942-7612	BULK	
5935-00-553-9352	12	3	5970-00-945-2849	BULK	
5940-00-557-1629	6	2	5970-00-948-6660	BULK	
5940-00-557-1629	13	9	5935-00-952-7408	25	8

SECTION IV

NATIONAL STOCK NUMBER AND PART NUMBER INDEX

TM 11-5821-285-30P

NOTE: LATEST NATIONAL STOCK NUMBER ASSIGNMENTS ARE INCLUDED AT END OF INDEX.

STOCK NUMBER	FIGURE. NO.	ITEM NO.	STOCK NUMBER	FIGURE. NO.	ITEM NO.
5305-00-954-0942	16	13	5305-00-984-6195	16	25
5305-00-954-0942	16	42	5305-00-984-6221	17	29
5970-00-954-1622	BULK		5305-00-988-1167	3	13
5970-00-954-1624	BULK		5305-00-988-1167	4	3
5305-00-958-0656	22	6	5305-00-988-1727	16	22
5310-00-959-7600	17	25	5305-00-989-6265	23	13
5935-00-964-4155	21	1	5305-00-989-7435	23	26
5310-00-982-6814	3	8	5305-00-993-0190	14	2
5310-00-983-8483	23	15	5305-00-993-0190	14	9
5305-00-984-4988	16	38	5310-01-006-2084	23	25
5305-00-984-4988	23	24	5315-01-027-6616	23	9
5305-00-984-4993	4	7	5935-01-043-0629	8	13
5305-00-984-6193	3	18	5935-01-043-0629	9	12
5305-00-984-6193	14	3	5935-01-043-0629	27	1
5305-00-984-6193	16	11	5945-01-052-6792	4	1
5305-00-984-6193	16	18	5340-01-057-1227	23	4
5305-00-984-6194	2	6	5970-01-094-0479	BULK	
5305-00-984-6194	3	19	5365-01-108-2256	11	8
5305-00-984-6195	16	6			

FSCM	PART NUMBER	FIGURE NO.	ITEM NO.	FSCM	PART NUMBER	FIGURE NO.	ITEM NO.
88044	AN-4-6A	17	21	96906	MS21919DG-14	16	19
80058	ANARC131	1	7	96906	MS21919DG-4	23	27
80058	ANARC51BX	1	17	96906	MS21919DG16	16	20
88044	AN101306	23	1	96906	MS21919DG18	16	9
88044	AN931-11-16	4	13	96906	MS24308-21-4	13	6
88044	AN931-11-16	25	4	96906	MS24665-132	23	9
88044	AN931-8-13	4	6	96906	MS25017-10	16	8
88044	AN931-8-13	25	2	96906	MS25017-15	16	15
88044	AN936B8	3	17	96906	MS25017-5	16	16
88044	AN960-C416	17	22	96906	MS525036-102	6	3
88044	AN960C6L	17	33	96906	MS25036-102	12	2
81860	B44DB4	23	19	96906	MS25036-102	13	2
81860	B64-B-20	16	58	96906	MS25036-103	11	4
81860	B64-BB-40	16	59	96906	MS25036-103	25	11
81349	C012L0F12-22-0325	BULK		96906	MS25036-149	6	2
81349	C012L0F12-22-0325	20	3	96906	MS25036-149	13	9
80058	C1611DAIC	1	5	96906	MS25036-156	23	29
80058	C6287/ARC-51BX	1	18	96906	MS25041-3	8	124
80058	C7088/ARC-131	1	8	96906	MS25041-3	9	70
80058	C8157ARC	1	13	96906	MS25098-22	16	40
71468	DCMA-378-C33	13	7	96906	MS2536-103	10	1
80058	HYL3TSEC	1	2	96906	MS27183-5	23	15
81349	JAN-1N645	25	13	96906	MS27183-8	2	7
56289	JN17-3346A	14	4	96906	MS27183-8	3	4
81349	MIL-I-631	10	13	96906	MS27183-8	23	12
81349	MILC6499TYPEA13A	16	1	96906	MS27473T18B32S	11	7
81349	MILW16878-4BGES9	BULK		96906	MS27506818-2	11	6
81349	MILW16878-4BGE9	BULK		96906	MS3057-16A	11	2
81349	MILW16878-4BGE9	15	2	96906	MS3102R28-16S	25	8
81349	MILW16878-4BJE9	BULK		96906	MS3106B28-16P	6	1
99974	MM3424	BULK		96906	MS3106B28-16P	11	1
96906	MS14108-2	23	4	96906	MS3112E12-10S	8	14
96906	MS15795-704	23	2	96906	MS3112E12-10S	9	13
96906	MS15795-814	17	16	96906	MS3112E18-32S	6	8
96906	MS17828-06C	23	10	96906	MS3114F16-26S	6	4
96906	MS17828-3F	23	25	96906	MS3114F16-26SW	6	6
96906	MS203922C1T	23	8	96906	MS311bE24-61S	8	5
96906	MS20427-3C5	14	8	96906	MS3116E24-61S	9	4
96906	MS20659-102	7	5	96906	MS3124E12-10P	3	23
96906	MS20659-102	8	11	96906	MS3124E12-10P	15	1
96906	MS20659-102	9	10	96906	MS3124E16-26PW	3	28
96906	MS20659-141	21	3	96906	MS3124E16-26PW 15	15	3
96906	MS21042-07	4	2	96906	MS3124E16-26S	24	1
96906	MS21042-02	16	32	96906	MS3124F10-6S	10	4
96906	MS21042-04	22	5	96906	MS3126F10-6P	10	16
96906	MS21042-08	3	16	96906	MS3126F12-14P	10	12
96906	MS21042-08	16	10	96906	MS3126F14-5S	10	8
96906	MS21042-08	16	17	96906	MS3126F16-26P	10	9
96906	MS21042-2	3	12	96906	MS3126F16-26PU	10	15
96906	MS21042-4	16	23	88044	MS3420-1	11	8
96906	MS21044C08	3	8	96906	MS3420-10A	10	10
96906	MS21044D08	2	5	96906	MS3420-4A	10	3
96906	MS21044N06	4	8	96906	MS3420-6A	10	6
96906	MS21044N06	17	34	96906	MS3420-8A	10	7
96906	MS21044N06	25	6	96906	MS3476F-16-26S	9	6
96906	MS21266-2N	23	20	96906	MS3476F12-10P	20	1

FSCM	PART NUMBER	FIGURE NO.	ITEM NO.	FSCM	PART NUMBER	FIGURE NO.	ITEM NO.
96906	MS3476F12-10S	8	8	81349	MWC20-7J904		BULK
96906	MS3476F12-10S	9	7	81349	MWC20-7J9045		BULK
96906	MS3476F12-10S	9	67	81349	MWC20-7J9046		BULK
96906	MS3476F12-102S	20	4	81349	MWC20-7J9047		BULK
96906	MS3476FI6-26S	8	1	81349	MWC20-7J9048		BULK
96906	MS535190-237	23	16	81349	MWC20-7J905		BULK
96906	MS35190-253	2	4	81349	MWC20-7J9056		BULK
96906	MS35190-253	3	7	81349	MWC20-7J9057		BULK
96906	MS35203-59	16	27	81349	MWC20-7J906		BULK
96906	MS35206-203	3	26	81349	MWC20-7J9067		BULK
96906	MS35206-203	16	33	81349	MWC20-7J9068		BULK
96906	MS35206-204	3	13	81349	MWC20-7J907		BULK
96906	MS35206-204	4	3	81349	MWC20-7J9078		BULK
96906	MS35206-214	14	2	81349	MWC20-7J908		BULK
96906	MS35206-214	14	9	81349	MWC20-7J912		BULK
96906	MS35206-230	4	14	81349	MWC20-7J9123		BULK
96906	MS35206-230	25	7	81349	MWC20-7J9124		BULK
96906	MS35206-233	4	7	81349	MWC20-7J9125		BULK
96906	MS35206-234	17	29	81349	MWC20-7J9126		BULK
96906	MS35206-245	3	1	81349	MWC20-7J9127		BULK
96906	MS35206-245	14	3	81349	MWC20-7J9128		BULK
96906	MS35206-245	16	11	81349	MWC20-7J913		BULK
96906	MS35206-245	16	18	81349	MWC20-7J9134		BULK
96906	MS35206-246	2	6	81349	MWC20-7J9135		BULK
96906	MS35206-246	3	1	81349	MWC20-7J9136		BULK
96906	MS35206-247	16	6	81349	MWC20-7J9137		BULK
96906	MS35206-247	16	25	81349	MWC20-7J9138		BULK
96906	MS35206-25	16	38	81349	MWC20-7J914		BULK
96906	MS35206-25	23	24	81349	MWC20-7J9145		BULK
96906	MS35206-25	25	14	81349	MWC20-7J9146		BULK
96906	MS35206-283	16	22	81349	MWC20-7J9147		BULK
96906	MS35206-331	16	13	81349	MWC20-7J9148		BULK
96906	MS35206-331	16	42	81349	MWC20-7J915		BULK
96906	MS35207-218	22	6	81349	MWC20-7J9156		BULK
96906	MS35207-262	23	13	81349	MWC20-7J9157		BULK
96906	MS35207-264	23	26	81349	MWC20-7J9158		BULK
96906	MS35333-38	3	3	81349	MWC20-7J916		BULK
96906	MS35338-41	16	39	81349	MWC20-7J9167		BULK
96906	MS35338-42	2	8	81349	MWC20-7J9168		BULK
96906	MS35338-42	3	5	81349	MWC20-7J917		BULK
96906	MS35338-42	16	7	81349	MWC20-7J9178		BULK
96906	MS35338-42	16	24	81349	MWC20-7J918		BULK
96906	MS35338-42	16	41	81349	MWC20-7J923		BULK
96906	MS35338-46	17	12	81349	MWC20-7J9234		BULK
96906	MS35489-18	20	2	81349	MWC20-7J9235		BULK
96906	MS35489-7	25	5	81349	MWC20-7J9236		BULK
96906	MS35650-322	3	27	81349	MWC20-7J9237		BULK
96906	MS45904-57	16	14	81349	MWC20-7J9238		BULK
96906	MS51861-12	16	51	81349	MWC20-7J924		BULK
96906	MS51922-17	17	17	81349	MWC20-7J9245		BULK
96906	MS51922-5	17	25	81349	MWC20-7J9247		BULK
96906	MS51968-14	17	11	81349	MWC20-7J9248		BULK
96906	MS95904-69	23	3	81349	MWC20-7J925		BULK
81349	MWC20-7J9058	BULK		81349	MWC20-7J9256		BULK
81349	MWC18-7J0	BULK		81349	MWC20-7J9257		BULK
81349	MWC18-7J2	BULK		81349	MWC20-7J9258		BULK
81349	MWC18-7J9	BULK		81349	MWC20-7J926		BULK
B1349	MWC20-7JSJ9	BULK		81349	MWC20-7J9267		BULK
81349	MWC20-7JS9	9	35	81349	MWC20-7J9268		BULK
81349	MWC20-7J0	BULK		81349	MWC20-7J927		BULK
81349	MWC20-7J9	BULK		81349	MWC20-7J9278		BULK
81349	MWC20-7J9	9	66	81349	MWC20-7J928		BULK
81349	MWC20-7J9012	BULK		81349	MWC20-7J934		BULK
81349	MWC20-7J9013	BULK		81349	MWC20-7J9345		BULK
81349	MWC20-7J9014	BULK		81349	MWC20-7J9346		BULK
81349	MWC20-7J9015	BULK		81349	MWC20-7J9347		BULK
81349	MWC20-7J9016	BULK		81349	MWC20-7J935		BULK
81349	MWC20-7J9017	BULK		81349	MWC20-7J936		BULK
81349	MWC20-7J9018	BULK		81349	MWC20-7J937		BULK
81349	MWC20-7J9023	BULK		81349	MWC20-7J938		BULK
81349	MWC20-7J9024	BULK		81349	MWC20-7J945		BULK
81349	MWC20-7J9025	BULK		81349	MWC20-7J946		BULK
81349	MWC20-7J9026	BULK		81349	MWC20-7J947		BULK
81349	MWC20-7J9027	BULK		81349	MWC20-7J948		BULK
81349	MWC20-7J9028	BULK		81349	MWC20-7J956		BULK
81349	MWC20-7J9034	BULK		81349	MWC20-7J957		BULK
81349	MWC20-7J9035	BULK		81349	MWC20-7J958		BULK
81349	MWC20-7J9036	BULK		81349	MWC20-7J967		BULK
81349	MWC20-7J9037	BULK		81349	MWC20-7J968		BULK
81349	MWC20-7J9038	BULK		81349	MWC20-7J978		BULK

FSCM	PART NUMBER	FIGURE NO.	ITEM NO.	FSCM	PART NUMBER	FIGURE NO.	ITEM NO.
81349	M20466/2-036	23	23	80063	SC-B-972690	16	37
81349	M23053/2-105-0	BULK		80063	SC-B-972693	16	55
81349	M23053/2-105-0	9	14	80063	SC-B-972694	16	45
81349	M23053/2-106-0	BULK		80063	SC-C-972589	3	22
81349	M23053/2-107-0	BULK		80063	SC-C-972590	3	24
81349	M23053/2-108-0	BULK		80063	SC-C-972604	25	9
81349	M23053/2-109-0	BULK		80063	SC-C-972608	25	3
81349	M23053/5-103-0	BULK		80063	SC-C-972622	14	5
81349	M23053/5-104-0	BULK		80063	SC-C-972634	25	12
81349	M23053/5-105-0	BULK		80063	SC-C-972636	4	4
81349	M23053/5-107-0	BULK		80063	SC-C-972644	14	7
81349	M39006-09-6572	26	6	80063	SC-C-972647	14	1
81349	M39012/16-0004	5	3	80063	SC-C-972650	23	22
81349	M39012/16-0101	8	13	80063	SC-C-972650-4	16	34
81349	M39012/16-0101	9	12	80063	SC-C-972650-5	24	2
81349	M39012/16-0101	27	1	80063	SC-C-972650-9	16	3
81349	M39016/6-128M	4	1	80063	SC-C-972651	3	15
81349	M5086/1-16-9	BULK		80063	SC-C-972659	23	11
81349	M5086/1-18-0	BULK		80063	SC-C-972660	23	14
81349	M5086/1-18-1	BULK		80063	SC-C-972662	23	18
81349	M5086/1-18-2	BULK		80063	SC-C-972663	23	17
81349	M5086/1-18-3	BULK		80063	SC-C-972665	23	6
81349	M5086/1-18-4	BULK		80063	SC-C-972666	16	5
81349	M5086/1-20-9	BULK		80063	SC-C-972667	16	50
81349	M5086/1-20-90	BULK		80063	SC-C-972677	16	57
81349	M5086/1-20-901	BULK		80063	SC-C-972678	16	2
81349	M5086/1-20-902	BULK		80063	SC-C-972686	16	35
81349	M5086/1-20-903	BULK		80063	SC-C-972691	16	56
81349	M5086/1-20-91	BULK		80063	SC-C-972717	1	21
81349	M5086/1-20-92	BULK		80063	SC-C-972717-1Z	5	2
81349	M5086/1-20-93	BULK		80063	SC-C-972721	16	12
81349	M5086/1-20-94	BULK		80063	SC-C-972729	16	4
81349	M5086/1-20-95	BULK		80063	SC-C-972736	17	15
81349	M5086/1-20-96	BULK		80063	SC-C-972737	17	28
81349	M5086/1-20-97	BULK		80063	SC-C-972741	17	32
81349	M5086/1-20-98	BULK		80063	SC-C-972753	17	18
81349	M7078-2-20-1	BULK		80063	SC-C-972755	17	20
81349	M7078-2-20-1	6	10	80063	SC-C-972774	17	24
81349	M9177/1-1	22	1	80063	SC-C-972783	22	4
81349	M9177/3-1	22	3	80063	SC-C-972784	17	7
92194	PVC105 1-2BLACK	BULK		80063	SC-C-972786	17	1
79372	P102F-6-1	17	30	80063	SC-C-972787	17	2
81348	QQB57R36T078	BULK		80063	SC-C-972788	17	3
81349	QQB87R34T131	BULK		80063	SC-C-972801-4	1	12
81349	QQB875R34T131	23	28	80063	SC-C-972802	1	31
81349	RCR20G101JS	26	1	80063	SC-D-972561	1	1
81349	RCR20G102JS	25	10	80063	SC-D-972582	1	10
81349	RCR20G121JS	26	2	80063	SC-D-972583	3	10
81349	RCR20G151JS	6	9	83063	SC-D-972585	3	1
81349	RCR20G151JS	11	9	80063	SC-D-972586	3	6
81349	RCR20G151JS	26	3	80063	SC-D-972592	2	1
81349	RCR20G241JS	26	4	80063	SC-D-972592	3	20
81349	RCR20G271JS	26	5	80063	SC-D-972593	1	11
80058	RG58CU	BULK		80063	SC-D-972594	2	11
80058	RG58U	27	2	80063	SC-D-972596	2	10
80058	RT-1167/ARC-164	1	14	80063	SC-D-972597	2	2
80058	RT742/ARC-51BX	1	19	80063	SC-D-972599	1	16
80058	RT823/ARC-131	1	9	80063	SC-D-972600	25	1
80063	SC-B-972591	3	21	80063	SC-D-972609	26	7
80063	SC-B-972603	4	10	80063	SC-D-972610	1	15
80063	SC-B-972603	25	17	80063	SC-D-972612	4	5
80063	SC-B-972606	4	12	80063	SC-D-972614	1	30
80063	SC-B-972607	4	9	80063	SC-D-972615	14	6
80063	SC-B-972607	25	18	80063	SC-D-972632	25	15
80063	SC-B-972619	14	10	80063	SC-D-972648	1	4
80063	SC-B-972624	3	14	80063	SC-D-972649	23	21
80063	SC-B-972625	3	11	80063	SC-D-972650-4	24	4
80063	SC-B-972626	3	25	80063	SC-D-972650-9	24	3
80063	SC-B-972637	4	11	80063	SC-D-972653	1	3
80063	SC-B-972668	16	52	80063	SC-D-972654	23	7
80063	SC-B-972669	16	54	80063	SC-D-972664	23	5
80063	SC-B-972670	16	46	80063	SC-D-972683	16	30
80063	SC-B-972671	16	47	80063	SC-D-972695	16	26
80063	SC-B-972672	16	53	80063	SC-D-972696	16	29
80063	SC-B-972673	16	48	80063	SC-D-972700	1	29
80063	SC-B-972674	16	49	80063	SC-D-972700-1	13	4
80063	SC-B-972684	16	31	80063	SC-D-972700-1	13	5
80063	SC-B-972687	16	60	80063	SC-D-972700-4	13	3
80063	SC-B-972688	16	43	80063	SC-D-972700-5	13	8
80063	SC-B-972689	16	44	80063	SC-D-972700-6	13	1

FSCM	PART NUMBER	FIGURE NO.	ITEM NO.	FSCM	PART NUMBER	FIGURE NO.	ITEM NO.
80063	SC-D-972701	1	27	80063	SC-D-972714-1Z	8	34
80063	SC-D-972102	1	26	80063	SC-D-972714-1ZA	8	35
80063	SC-D-972703	1	28	80063	SC-D-972714-1ZB	8	37
80063	SC-D-972704	1	33	80063	SC-D-972714-1ZC	8	38
80063	SC-D-972705	1	32	80063	SC-D-972714-1ZD	8	39
80063	SC-D-972706	1	23	80063	SC-D-972714-1ZE	8	40
80063	SC-D-972706-1Z	6	5	80063	SC-D-972714-1ZF	8	41
80063	SC-D-972706-2	6	7	80063	SC-D-972714-1ZG	8	42
80063	SC-D-972706-8	6	12	80063	SC-D-972714-1ZH	8	43
80063	SC-D-972706-9	6	11	80063	SC-D-972714-1ZJ	8	44
80063	SC-D-972707	1	34	80063	SC-D-972714-1ZK	8	45
80063	SC-D-972707-1Z	7	2	80063	SC-D-972714-1ZL	8	46
80063	SC-D-972707-2	7	3	80063	SC-D-972714-1ZM	8	47
80063	SC-D-972707-3	7	4	80063	SC-D-972714-1ZN	8	48
80063	SC-D-972707-4	7	1	80063	SC-D-972714-1ZP	8	49
80063	SC-D-972708	1	24	80063	SC-D-972714-1ZQ	8	50
80063	SC-D-972708-13	8	15	80063	SC-D-972714-1ZR	8	51
80063	SC-D-972709	1	25	80063	SC-D-972714-1ZS	8	52
80063	SC-D-972711	1	22	80063	SC-D-972714-1ZT	8	53
80063	SC-D-972711-1	10	14	80063	SC-D-972714-1ZU	8	54
80063	SC-D-972711-1Z	10	21	80063	SC-D-972714-1ZV	8	55
80063	SC-D-972711-2	10	2	80063	SC-D-972714-1ZV	8	56
80063	SC-D-972711-2A	10	11	80063	SC-D-972714-1ZX	8	57
80063	SC-D-972711-20	10	19	80063	SC-D-972714-1ZY	8	58
80063	SC-D-972711-21	10	18	80063	SC-D-972714-1ZZZ	8	59
80063	SC-D-972711-23	10	20	80063	SC-D-972714-1Z1	8	60
80063	SC-D-972711-24	10	23	80063	SC-D-972714-1Z2	8	61
80063	SC-D-972711-25	10	22	80063	SC-D-972714-2A	8	36
80063	SC-D-972711-3	10	5	80063	SC-D-972714-3	8	12
80063	SC-D-972711-4	10	17	80063	SC-D-972714-4	8	4
80063	SC-D-972712	8	3	80063	SC-D-972714-5	8	6
80063	SC-D-972712-2	8	10	80063	SC-D-972715	8	1
80063	SC-D-972712-3A	8	126	80063	SC-D-972715-1A	8	100
80063	SC-D-972712-3B	8	140	80063	SC-D-972715-1B	8	101
80063	SC-D-972712-3C	8	128	80063	SC-D-972715-1C	8	102
80063	SC-D-972712-3D	8	134	80063	SC-D-972715-1D	8	103
80063	SC-D-972712-3E	8	127	80063	SC-D-972715-1E	8	104
80063	SC-D-972712-4A	8	139	80063	SC-D-972715-1F	8	105
80063	SC-D-972712-4B	8	130	80063	SC-D-972715-1G	8	106
80063	SC-D-972712-4C	8	129	80063	SC-D-972715-1H	8	107
80063	SC-D-972712-4D	8	123	80063	SC-D-972715-1J	8	108
80063	SC-D-972712-4E	8	138	80063	SC-D-972715-1K	8	109
80063	SC-D-972712-4F	8	137	80063	SC-D-972715-1L	8	110
80063	SC-D-972712-4G	8	135	80063	SC-D-972715-1M	8	111
80063	SC-D-972712-4H	8	125	80063	SC-D-972715-1N	8	112
80063	SC-D-972712-4J	8	131	80063	SC-D-972715-1P	8	113
80063	SC-D-972712-4K	8	133	80063	SC-D-972715-1Q	8	115
80063	SC-D-972712-4L	8	132	80063	SC-D-972715-1R	8	116
80063	SC-D-972712-4M	8	136	80063	SC-D-972715-1S	8	72
80063	SC-D-972712-5	8	122	80063	SC-D-972715-1T	8	73
80063	SC-D-972713	1	20	80063	SC-D-972715-1U	8	74
80063	SC-D-972713-12	11	11	80063	SC-D-972715-1V	8	75
80063	SC-D-972713-2	11	5	80063	SC-D-972715-1W	8	76
80063	SC-D-972713-5	11	3	80063	SC-D-972715-1X	8	77
80063	SC-D-972713-6	11	10	80063	SC-D-972715-1Y	8	78
80063	SC-D-972714	8	2	80063	SC-D-972715-1Z	8	79
80063	SC-D-972714-1	8	66	80063	SC-D-972715-1ZA	8	121
80063	SC-D-972714-1A	8	23	80063	SC-D-972715-1ZB	8	80
80063	SC-D-972714-1B	8	16	80063	SC-D-972715-1ZC	8	81
80063	SC-D-972714-1C	8	17	80063	SC-D-972715-1ZD	8	82
80063	SC-D-972714-1D	8	18	80063	SC-D-972715-1ZE	8	83
80063	SC-D-972714-1E	8	19	80063	SC-D-972715-1ZF	8	84
80063	SC-D-972714-1F	8	20	80063	SC-D-972715-1ZG	8	85
80063	SC-D-972714-1G	8	21	80063	SC-D-972715-1ZH	8	86
80063	SC-D-972714-1H	8	22	80063	SC-D-972715-1ZJ	8	87
80063	SC-D-972714-1J	8	67	83063	SC-D-972715-1ZK	8	88
80063	SC-D-972714-1K	8	24	80063	SC-D-972715-1ZL	8	117
80063	SC-D-972714-1L	8	25	80063	SC-D-972715-1ZM	8	118
80063	SC-D-972714-1M	8	26	80063	SC-D-972715-1ZN	8	119
80063	SC-D-972714-1N	8	27	80063	SC-D-972715-1ZP	8	120
80063	SC-D-972714-1P	8	28	83063	SC-D-972715-1ZQ	8	91
80063	SC-D-972714-1Q	8	29	80063	SC-D-972715-1ZR	8	90
80063	SC-D-972714-1R	8	30	80063	SC-D-972715-1ZS	8	89
80063	SC-D-972714-1S	8	31	80063	SC-D-972715-1ZT	8	92
80063	SC-D-972714-1T	8	32	80063	SC-D-972715-1ZU	8	93
80063	SC-D-972714-1U	8	62	80063	SC-D-972715-1ZV	8	94
80063	SC-D-972714-1V	8	63	80063	SC-D-972715-1ZW	8	96
80063	SC-D-972714-1W	8	64	80063	SC-D-972715-1ZX	8	97
80063	SC-D-972714-1X	8	65	80063	SC-D-972715-1ZY	8	98
80063	SC-D-972714-1Y	8	33	80063	SC-D-972715-1ZZ	8	99

FSCM	PART NUMBER	FIGURE NO.	ITEM NO.	FSCM	PART NUMBER	FIGURE NO.	ITEM NO.
80063	SC-D-972715-1Z1	8	114	80063	SC-D-972716-2	9	9
80063	SC-D-972715-1Z3	8	95	80063	SC-D-972716-2B	9	58
80063	SC-D-972715-2	8	70	80063	SC-D-972716-3	9	11
80063	SC-D-972715-3	8	71	80063	SC-D-972716-4	9	3
80063	SC-D-972715-4	8	68	80063	SC-D-972716-5	9	5
80063	SC-D-972715-5	8	69	80063	SC-D-972718	9	2
80063	SC-D-972716	9	1	80063	SC-D-972718-2A	9	71
80063	SC-D-972716-1	9	65	80063	SC-D-972718-28	9	78
80063	SC-D-972716-1A	9	44	80063	SC-D-972718-2C	9	72
80063	SC-D-972716-1B	9	45	80063	SC-D-972718-3A	9	77
80063	SC-D-972716-1C	9	46	80063	SC-D-972718-3B	9	76
80063	SC-D-972716-1D	9	47	80063	SC-D-972718-3C	9	75
80063	SC-D-972716-1E	9	48	80063	SC-D-972718-3D	9	74
80063	SC-D-972716-1F	9	49	80063	SC-D-972718-3E	9	73
80063	SC-D-972716-1G	9	50	80063	SC-D-972718-3F	9	68
80063	SC-D-972716-1H	9	51	89063	SC-D-972718-4	9	69
80063	SC-D-972716-1J	9	52	80063	SC-D-972731	17	10
80063	SC-D-972716-1K	9	53	80063	SC-D-972733	17	14
80063	SC-D-972716-1L	9	54	80063	SC-D-972749	17	19
80063	SC-D-972716-1M	9	55	80063	SC-D-972777	17	23
80063	SC-D-972716-1N	9	56	80063	SC-D-972778	17	27
80063	SC-D-972716-1P	9	57	80063	SC-D-972780	17	5
80063	SC-D-972716-1Q	9	59	80063	SC-D-972780-1	21	2
80063	SC-D-972716-1R	9	60	80063	SC-D-972782-5	22	2
80063	SC-D-972716-1S	9	15	80063	SC-D-972784-1	19	2
80063	SC-D-972116-1T	9	16	80063	SC-D-972785	17	8
80063	SC-D-972716-1U	9	17	80063	SC-D-972787-1	18	2
80063	SC-D-972716-1V	9	18	80063	SC-D-972789	17	6
80063	SC-D-972716-1W	9	19	80063	SC-D-972790	17	9
80063	SC-D-972716-1X	9	20	80063	SC-D-972791	17	4
80063	SC-D-972716-1Y	9	21	80063	SC-D-972794	17	26
80063	SC-D-972716-1Z	9	22	80063	SC-D-972801-2-1	12	1
80063	SC-D-972716-1ZB	9	23	80063	SC-D-9824	16	28
80063	SC-D-972716-1ZC	9	24	81860	SLR2AB	2	3
80063	SC-D-972716-1ZD	9	25	81860	SLR2AB	3	9
80063	SC-D-972716-1ZE	9	26	80063	SM-B-620336	9	8
80063	SC-D-972716-1ZF	9	27	78286	S1535-61262-4	17	13
80063	SC-D-972716-1ZG	9	28	80058	TSEC/KY-28	1	6
80063	SC-D-972716-1ZH	9	29	80058	UG-536C/U	27	3
80063	SC-D-972716-1ZJ	9	30	81349	UG1366U	5	1
80063	SC-D-972716-1ZK	9	31	81349	UG88EU	18	1
80063	SC-D-972716-1ZL	9	61	80058	UG913BU	19	1
80063	SC-D-972716-1ZM	9	62	80058	U383VR	16	36
80063	SC-D-972716-1ZN	9	63	80058	U94A/U	12	3
80063	SC-D-972716-1ZP	9	64	81349	WM85U	BULK	
80063	SC-D-972716-1ZQ	9	34	07240	ZTZ-0250-63-20BLACK	BULK	
80063	SC-D-972716-1ZR	9	33	02660	164-201-1S17	21	1
80063	SC-D-972716-1ZS	9	32	81860	3098 005 000	2	9
80063	SC-D-972716-1ZT	9	36	81860	3098 005 000	3	2
80063	SC-D-972716-1ZU	9	37	96214	411634-1000	BULK	
80063	SC-D-972716-1ZV	9	38	96214	411634-8800	BULK	
80063	SC-D-972716-1ZW	9	40	29372	5102F6-04	17	31
80063	SC-D-972716-1ZX	9	41	81348	6041H80A	16	21
80063	SC-D-972716-1ZY	9	42	37695	709299-801	8	9
80063	SC-D-972716-1ZZ	9	43	24617	778578	BULK	
80063	SC-D-972716-1Z1	9	39	83330	8502	25	16

LATEST NATIONAL STOCK NUMBER ASSIGNMENTS

STOCK NUMBER	FIGURE NO.	ITEM NO.
5821-00-651-1096	1	9
5935-00-201-3998	16	61

LATEST PART NUMBER ASSIGNMENTS

FSCM	PART NUMBER	FIGURE NO.	ITEM NO.
80058	RT-823/ARC-131	1	9
80063	SC-D-972592	2	1
81349	UW2020MA00	16	61

127/(128 blank)

By Order of the Secretary of the Army:

Official:

ROBERT M. JOYCE
Major General United States Army
The Adjutant General

JOHN A. WICKHAM, JR.
General United States Army
Chief of Staff

DISTRIBUTION:

To be distribution in accordance with DA Form 12-36, Direct and General Support Maintenance requirements for AN/ASC- 15.

* U.S. GOVERNMENT PRINTING OFFICE: 1992 O - 325-096 (45089)

RECOMMENDED CHANGES TO EQUIPMENT TECHNICAL PUBLICATIONS



THEN...JOT DOWN THE DOPE ABOUT IT ON THIS FORM. CAREFULLY TEAR IT OUT, FOLD IT AND DROP IT IN THE MAIL.

SOMETHING WRONG WITH THIS PUBLICATION?

FROM: (PRINT YOUR UNIT'S COMPLETE ADDRESS)

DATE SENT

PUBLICATION NUMBER

TM 11-5821-285-30P

PUBLICATION DATE

1 Sep 83

PUBLICATION TITLE Communications
Central AN/ASC-15A(V)1 and
AN/ASC-15A(V)2

BE EXACT PIN-POINT WHERE IT IS

PAGE NO.	PARA-GRAPH	FIGURE NO.	TABLE NO.
----------	------------	------------	-----------

IN THIS SPACE TELL WHAT IS WRONG AND WHAT SHOULD BE DONE ABOUT IT:

TEAR ALONG PERFORATED LINE

PRINTED NAME GRADE OR TITLE AND TELEPHONE NUMBER

SIGN HERE

DA FORM 2028-2
1 JUL 79

PREVIOUS EDITIONS ARE OBSOLETE

P.S.--IF YOUR OUTFIT WANTS TO KNOW ABOUT YOUR RECOMMENDATION MAKE A CARBON COPY OF THIS AND GIVE IT TO YOUR HEADQUARTERS.

